



First Choice
Group

SPARE PARTS DIAGRAM FOR



HOSHIZAKI

Ice Machine
IM-45LE
IM-45LE-25

First Choice Group
Blakeney Way, Kingswood Lakeside
Cannock, Staffs, WS11 8LD
TEL: 01543 577778 FAX: 01543504141
Email: enquires@firstchoice-cs.co.uk
Web: www.firstchoice-cs.co.uk

NO. -1780

ISSUED: APR. 1996

REVISED: DEC. 2011



**HOSHIZAKI
SELF-CONTAINED CUBER**

**MODEL IM-45LE
IM-45LE-25**

PARTS LIST

MATERIAL ABBREVIATIONS

ALUMINUM

AL = Aluminum

COPPER

CU = Copper

PLASTIC

ABS = Acrylonitrile -butadiene - styrene
AC = Polyacetal
EVA = Ethylene vinyl acetate
PA = Polyamide = Nylon
PC = Polycarbonate
PE = Polyethylene
PES = Polyester
PETP = Polyethylene terephthalate = Tetlon
PP = Polypropylene
PS = Polystyrene
PTFE = Polytetrafluoroethylene = Teflon
PUR = Polyurethane
PVC = Polyvinyl chloride

RUBBER

VN = Vinyl Nitrile
EPDM = EP rubber
NBR = Nitrile butadiene rubber
NR = Natural rubber
NP = Neoprene
SI.R = Silicone rubber
SY.R = Synthetic rubber
EPH = Epichlorohydrin

STEEL

GS = Galvanized steel
SS = Stainless steel
PS = Plated steel
PAS = Primed steel

AUXILIARY CODE

K-0

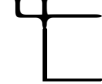

Designates the year. "K" indicates the year 2000. Years progress or regress in alphabetical order. "J" is 1999, "L" is 2001, "M" is 2002, and so on. The letters "I" and "O" were skipped.

Designates significant part changes within the same year. Base is 0 and this number advances for each change.

Example: P-1



"P" indicates 2004.

"1" indicates the first significant part change for 2004.

MARKS LOCATED UNDER THE AUXILIARY CODE

- = Part deleted.
- x = Part deleted and replaced by "o" part.
- o = New part in place of "x" part.

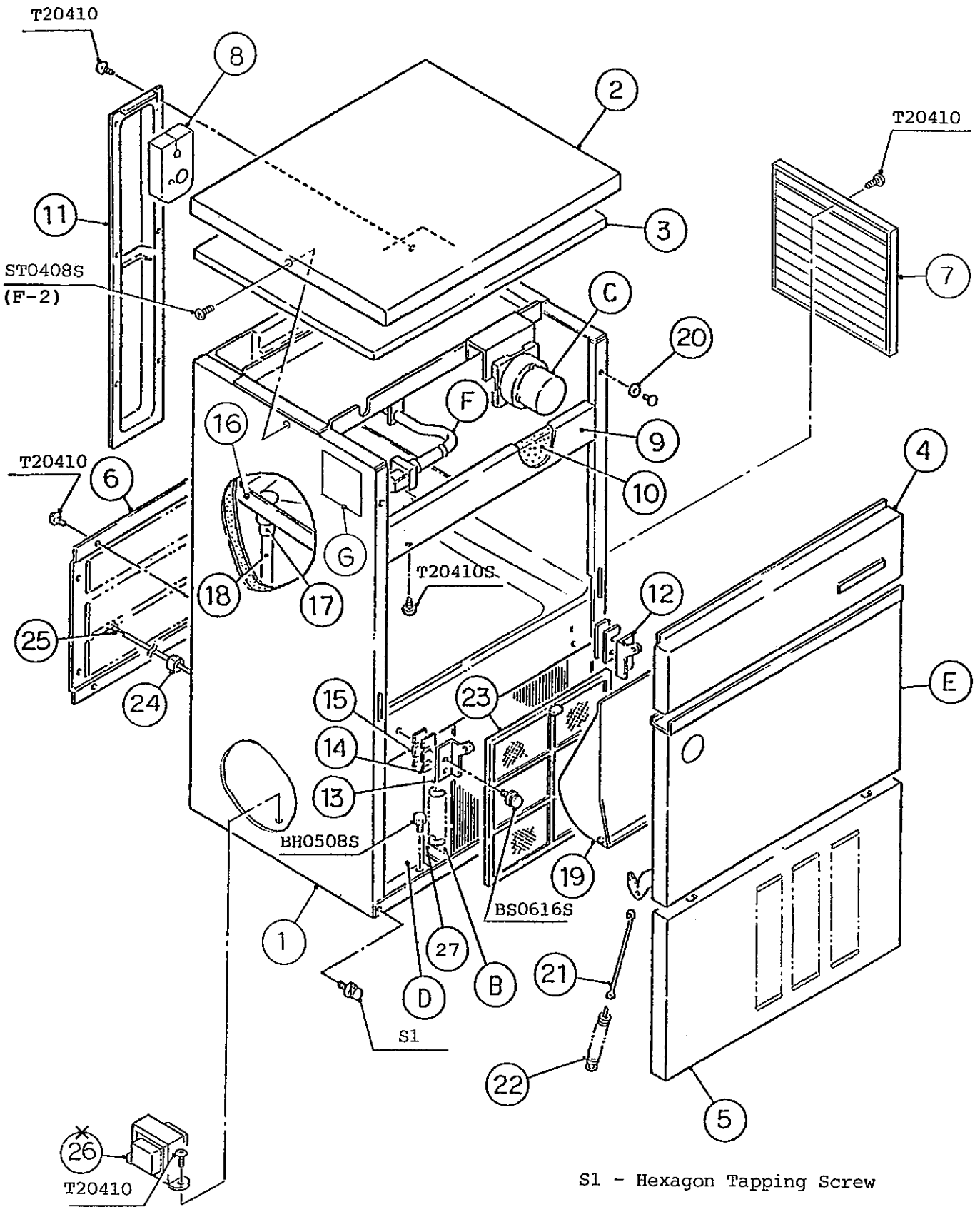

IM-45LE
IM-45LE-25

A. ICE CUBER ASSY

(R-0) (S-0)
(D-2) (E-0) (E-1) (E-2)
(C-0) (C-1) (D-0) (D-1)
(K-0) (K-1) (A-0) (B-0)
(G-1) (H-0) (H-1) (J-0)

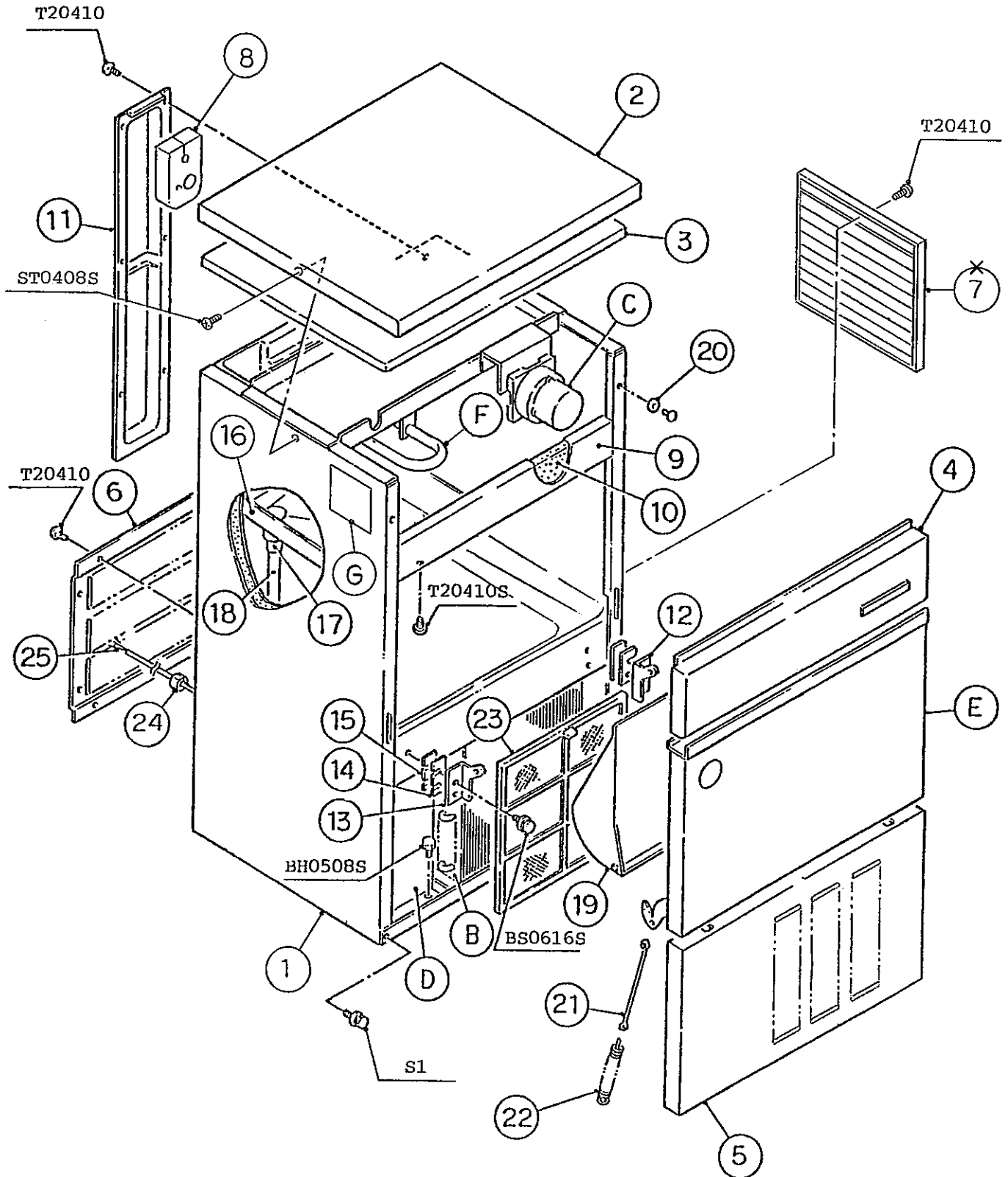

S1 - Hexagon Tapping Screw

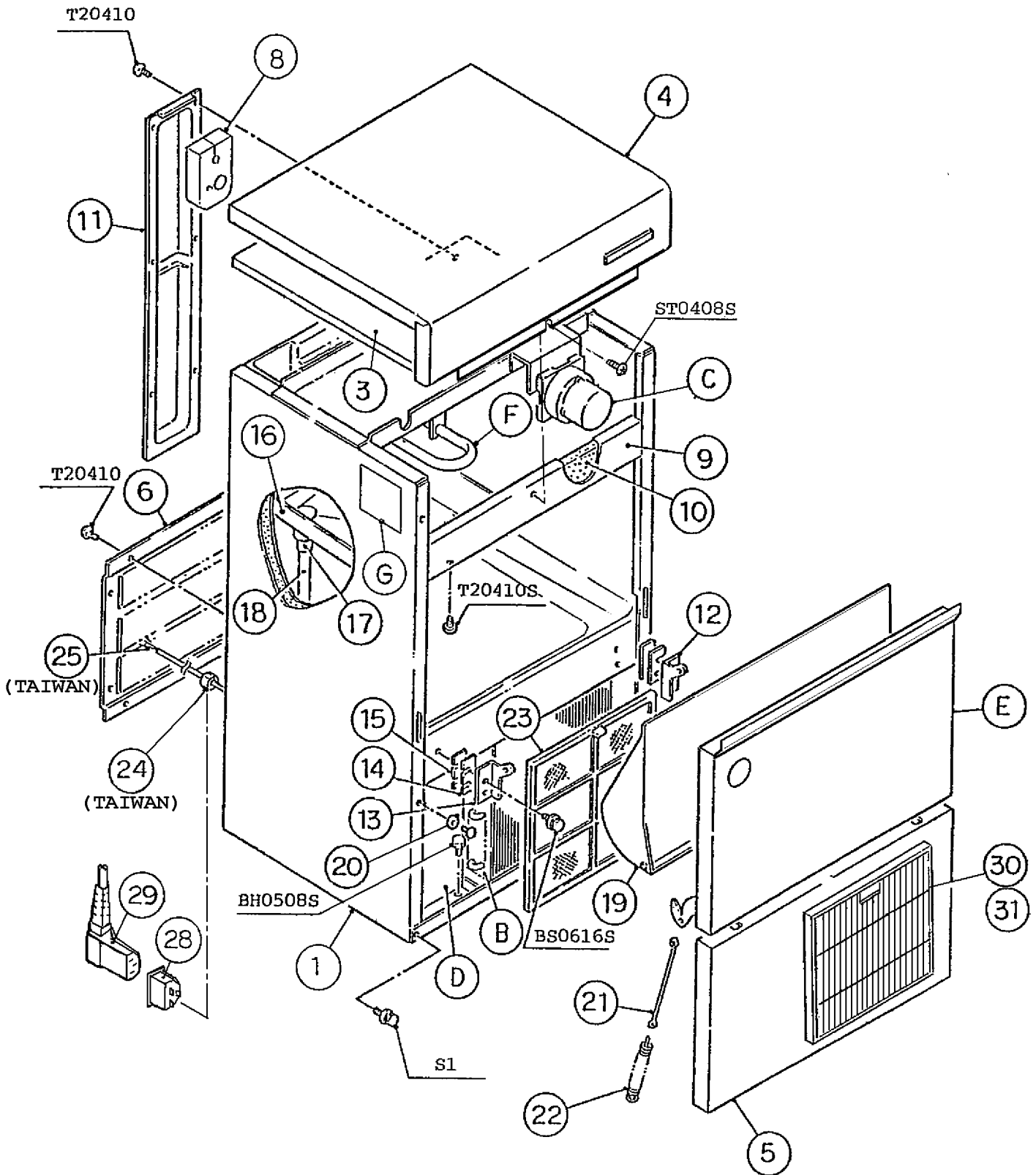

S1 - Hexagon Tapping Screw

HE, GENERAL, OCEANIA, RINNAI, KOREA, AUSTRALIA, HSP, TAIWAN

MODEL : IM-45LE, IM-45LE-25				TITLE : A. ICE CUBER ASSY			
INDEX NO.	DESCRIPTION	MATERIAL OR MODEL NUMBER	PART NUMBER	REQ'D NUMBER			
				F-1	F-2	G-1 H-0	H-1 J-0 K-0
B	REFRIGERATION UNIT	(IM-45LE)	1H1384A01	1	1	1	1
			1H2856A01				
			1H3337A01				
	REFRIGERATION UNIT	(IM-45LE-25)	-	1	1	1	1
C	ICE MAKING MECHANISM ASSY	(IM-45LE)	1H0253A09	1	1	1	1
			1H0253A14				
	ICE MAKING MECHANISM ASSY	(IM-45LE-25)	-	1	1	1	1
D	CONTROL BOX ASSY	-	2H2577A02	1	-		
			2H3209A01		1	1	-
			2H3209A03				1
			2H3209A05				
			2H3209A08				
			2H6762A01				
E	DOOR ASSY	-	3H0283A08	1	1	1	1
			3Y2754A01				
			3Y2899A01				
F	WATER CIRCUIT ASSY	-	3H8704A02	1	1	-	
			3H9600A01			1	1
G	LABEL LOCATION	-	3H8960A01	1	1	1	-
			3X1503A01				1
1	UNIT FRAME	S.S, G.S	1H0263G08	1	1	1	1
			1H0263G10				
			1H2949G01				
			1H2949G06				
	UNIT FRAME	(TAIWAN)	1H2949G03				
2	TOP PANEL	S.S	3H5119-02	1	-		
		S.S	3H9606-02		1	1	1
3	INSULATION - TOP PANEL	PE	2H0655-02	1	1	1	1
4	FRONT PANEL (UPPER)	S.S	3H8109G02	1	1	1	1
		S.S	3X7334G02				
	FRONT PANEL (UPPER)	(RINNAI)	3H8109G06	1	1	1	1
5	FRONT PANEL (LOWER)	S.S	3H8928-01	1	1	1	1
		S.S	3Y2760M01				
6	REAR PANEL	G.S	3H2213-01	1	1	1	1

HE, GENERAL, OCEANIA, RINNAI, KOREA, AUSTRALIA, HSP, TAIWAN

MODEL : IM-45LE, IM-45LE-25								TITLE : A. ICE CUBER ASSY			
INDEX NO.	DESCRIPTION	MATERIAL OR MODEL NUMBER	PART NUMBER	REQ'D NUMBER							
				K-1,A-0 B-0,C-0	C-1 D-0	D-1	D-2 E-0				
B	REFRIGERATION UNIT	(IM-45LE)	1H1384A01	1	—						
			1H2856A01		1	1	1				
			1H3337A01								
	REFRIGERATION UNIT	(IM-45LE-25)	-	1	1	1	1				
C	ICE MAKING MECHANISM ASSY	(IM-45LE)	1H0253A09	—							
			1H0253A14	1	1	1	1				
	ICE MAKING MECHANISM ASSY	(IM-45LE-25)	-	1	1	1	1				
D	CONTROL BOX ASSY	-	-								
		-	-								
		-	2H3209A03	—							
		-	2H3209A05	1	1	1	—				
		-	2H3209A08				1				
		-	2H6762A01								
E	DOOR ASSY	-	3H0283A08	1	1	1	1				
		-	3Y2754A01								
		-	3Y2899A01								
F	WATER CIRCUIT ASSY	-	-								
		-	3H9600A01	1	1	1	1				
G	LABEL LOCATION	-	3X1503A01	1	1	1	1				
		-	3X1503A02								
1	UNIT FRAME	S.S, G.S	1H0263G08	1	—						
			1H0263G10		1	—					
			1H2949G01			1	1				
			1H2949G06								
	UNIT FRAME	(TAIWAN)	1H2949G03				1				
2	TOP PANEL	-	-								
		S.S	3H9606-02	1	1	1	1				
3	INSULATION - TOP PANEL	PE	2H0655-02	1	1	1	1				
4	FRONT PANEL (UPPER)	S.S	3H8109G02	1	1	1	1				
		S.S	3X7334G02								
	FRONT PANEL (UPPER)	(RINNAI)	3H8109G06	1	1	1	1				
5	FRONT PANEL (LOWER)	S.S	3H8928-01	1	1	1	1				
		S.S	3Y2760M01								
6	REAR PANEL	G.S	3H2213-01	1	1	1	1				

HE, GENERAL, OCEANIA, RINNAI, KOREA, AUSTRALIA, HSP, TAIWAN, CHINA

MODEL : IM-45LE, IM-45LE-25 TITLE : A. ICE CUBER ASSY							
INDEX NO.	DESCRIPTION	MATERIAL OR MODEL NUMBER	PART NUMBER	REQ'D NUMBER			
				E-1	E-2 R-0 S-0	S-1	S-2,T-0 U-0,V-0 L-0
B	REFRIGERATION UNIT	(IM-45LE)	1H2856A01	1	—		
			1H3337A01		1	1	1
		(IM-45LE-25)	-	1	1	1	1
C	ICE MAKING MECHANISM ASSY	(IM-45LE)	1H0253A14	1	1	1	1
		(IM-45LE-25)	-	1	1	1	1
D	CONTROL BOX ASSY	-	2H3209A08	—			
		-	2H6762A01	1	1	1	1
E	DOOR ASSY	-	3H0283A08	1	1	—	
		-	3Y2754A01			1	—
		-	3Y2899A01				1
F	WATER CIRCUIT ASSY	-	3H9600A01	1	1	1	1
G	LABEL LOCATION	-	3X1503A01	—			
		-	3X1503A02	1	1	1	1
1	UNIT FRAME	S.S, G.S	1H2949G01	1	1	—	
			1H2949G06			1	1
		(TAIWAN)	1H2949G03	1	1	1	1
2	TOP PANEL	S.S	3H9606-02	1	1	×	
3	INSULATION - TOP PANEL	PE	2H0655-02	1	1	1	1
4	FRONT PANEL (UPPER)	S.S	3H8109G02	1	1	—	
		S.S	3X7334G02			1	1
5	FRONT PANEL (UPPER)	(RINNAI)	3H8109G06	1	1	×	
	FRONT PANEL (LOWER)	S.S	3H8928-01	1	1	—	
5	FRONT PANEL (LOWER)	S.S	3Y2760M01			1	1
		S.S	3Y2760M01			1	1
6	REAR PANEL	G.S	3H2213-01	1	1	1	1
7	-	-	-				
8	INSULATION	PE	4X5295-02	1	1	1	1
9	FRONT FRAME	S.S	3H1678-11	1	1	1	1
10	INSULATION - FRONT FRAME	PE, t20	4H2317-02	1	1	1	1
11	PIPE COVER	G.S	3H0202-03	1	1	1	1
12	HINGE (RIGHT)	S.S	4H2583-01	1	1	1	1
13	HINGE (LEFT)	S.S	4H2584-01	1	1	1	1
14	HINGE SPACER (A)	S.S	4H0605-01	REQ'D	REQ'D	REQ'D	REQ'D
15	HINGE SPACER (B)	S.S	4H0605-02	REQ'D	REQ'D	REQ'D	REQ'D
16	DRAIN PAN	ABS	2H1440-01	1	1	1	1

HE, GENERAL, OCEANIA, RINNAI, KOREA, AUSTRALIA, HSP, TAIWAN

MODEL : IM-45LE, IM-45LE-25				TITLE : A. ICE CUBER ASSY			
INDEX NO.	DESCRIPTION	MATERIAL OR MODEL NUMBER	PART NUMBER	REQ'D NUMBER			
				F-1	F-2	G-1 H-0	H-1 J-0 K-0
7	LOUVER	ABS	101812-09	1	1	1	1
8	INSULATION	PE	4X5295-02	1	1	1	1
9	FRONT FRAME	S.S	3H1678-11	1	1	1	1
10	INSULATION - FRONT FRAME	PE, t20	4H2317-02	1	1	1	1
11	PIPE COVER	G.S	3H0202-03	1	1	1	1
12	HINGE (RIGHT)	S.S	4H2583-01	1	1	1	1
13	HINGE (LEFT)	S.S	4H2584-01	1	1	1	1
14	HINGE SPACER (A)	S.S	4H0605-01	REQ'D	REQ'D	REQ'D	REQ'D
15	HINGE SPACER (B)	S.S	4H0605-02	REQ'D	REQ'D	REQ'D	REQ'D
16	DRAIN PAN	ABS	2H1440-01	1	1	1	1
17	DRAIN TUBE	SI	4H2585-01	1	1	1	1
18	DRAIN PIPE	ABS	4H1141-07	1	1	1	1
19	SLOPE	ABS	2H1349-01	1	1	1	1
20	COLLAR	S.S	4H0171-01	4	4	4	4
21	HOOK	S.S	404060-10	1	1	1	1
22	SPRING	ZINC-PLATED WIRE	416609-01	1	1	1	1
23	AIR FILTER	PP	332631G01	1	1	1	1
		PP	2A2063G01				
24	BUSHING	CEE SR-6P-10	448949-01	1	1	1	1
	BUSHING	SR-7K-2 (TAIWAN)	420742-02				
25	POWER SUPPLY CORD (CONTINENTAL)	(HE)	4X3520G01	1	—		
			452263-01		1	1	1
	POWER SUPPLY CORD (WITH UK PLUG)	(HE)	4X3521G01	1	1	1	1
	POWER SUPPLY CORD	(GENERAL) (OCEANIA)	458139-01			1	1
	POWER SUPPLY CORD	(RINNAI) (AUSTRALIA)	458139-01			1	1
	POWER SUPPLY CORD	(KOREA)	452263-01			1	1
	-	-	-				
26	TRANSFORMER	230V/100V	450104-01	1	x		
27	AIR GUIDE	G.S	3H5240-01	1	x		

HE, GENERAL, OCEANIA, RINNAI, KOREA, AUSTRALIA, HSP, TAIWAN

MODEL : IM-45LE, IM-45LE-25				TITLE : A. ICE CUBER ASSY			
INDEX NO.	DESCRIPTION	MATERIAL OR MODEL NUMBER	PART NUMBER	REQ'D NUMBER			
				K-1,A-0 B-0,C-0	C-1 D-0	D-1	D-2 E-0
7	LOUVER	ABS	101812-09	1	x		
8	INSULATION	PE	4X5295-02	1	1	1	1
9	FRONT FRAME	S.S	3H1678-11	1	1	1	1
10	INSULATION - FRONT FRAME	PE, t20	4H2317-02	1	1	1	1
11	PIPE COVER	G.S	3H0202-03	1	1	1	1
12	HINGE (RIGHT)	S.S	4H2583-01	1	1	1	1
13	HINGE (LEFT)	S.S	4H2584-01	1	1	1	1
14	HINGE SPACER (A)	S.S	4H0605-01	REQ'D	REQ'D	REQ'D	REQ'D
15	HINGE SPACER (B)	S.S	4H0605-02	REQ'D	REQ'D	REQ'D	REQ'D
16	DRAIN PAN	ABS	2H1440-01	1	1	1	1
17	DRAIN TUBE	SI	4H2585-01	1	1	1	1
18	DRAIN PIPE	ABS	4H1141-07	1	1	1	1
19	SLOPE	ABS	2H1349-01	1	1	1	1
20	COLLAR	S.S	4H0171-01	4	4	4	4
21	HOOK	S.S	404060-10	1	1	1	1
22	SPRING	ZINC-PLATED WIRE	416609-01	1	1	1	1
23	AIR FILTER	PP	332631G01	1	1	1	1
		PP	2A2063G01				
24	BUSHING	CEE SR-6P-10	448949-01	1	1	1	1
	BUSHING	SR-7K-2 (TAIWAN)	420742-02				1
25	POWER SUPPLY CORD (CONTINENTAL)	(HE) (KOREA)	452263-01	1	1	1	1
	POWER SUPPLY CORD (WITH UK PLUG)	(HE) (HSP)	4X3521G01	1	1	1	1
	POWER SUPPLY CORD	(GENERAL) (OCEANIA)	4X3520G01	1	1	1	1
	POWER SUPPLY CORD	(RINNAI) (AUSTRALIA)	458139-01	1	1	1	1
	-	-	-				
	POWER SUPPLY CORD	(TAIWAN)	4A1173-01				1
26	-	-	-				
27	-	-	-				

HE, GENERAL, OCEANIA, RINNAI, KOREA, AUSTRALIA, HSP, TAIWAN, CHINA

MODEL : IM-45LE, IM-45LE-25 TITLE : A. ICE CUBER ASSY							
INDEX NO.	DESCRIPTION	MATERIAL OR MODEL NUMBER	PART NUMBER	REQ'D NUMBER			
				E-1	E-2 R-0 S-0	S-1	S-2,T-0 U-0,V-0 L-0
17	DRAIN TUBE	SI	4H2585-01	1	1	1	1
18	DRAIN PIPE	ABS	4H1141-07	1	1	1	1
19	SLOPE	ABS	2H1349-01	1	1	1	1
20	COLLAR	S.S	4H0171-01	4	4	2	2
21	HOOK	S.S	404060-10	1	1	1	1
22	SPRING	ZINC-PLATED WIRE	416609-01	1	1	1	1
23	AIR FILTER	PP	332631G01	1	1	—	
		PP	2A2063G01			1	1
24	BUSHING	CEE SR-6P-10	448949-01	1	1	x	
	BUSHING	SR-7K-2 (TAIWAN)	420742-02	1	1	1	1
25	POWER SUPPLY CORD (CONTINENTAL)	(HE) (KOREA)	452263-01	1	1	x	
	POWER SUPPLY CORD (WITH UK PLUG)	(HE) (HSP)	4X3521G01	1	1	x	
	POWER SUPPLY CORD	(GENERAL) (OCEANIA)	4X3520G01	1	1	x	
	POWER SUPPLY CORD	(RINNAI) (AUSTRALIA)	458139-01	1	1	x	
	-	-	-				
	POWER SUPPLY CORD	(TAIWAN)	4A1173-01	1	1	1	1
26	-	-	-				
27	-	-	-				
28	CONNECTOR	-	P00245-01			1	1
29	POWER CORD	(CONTINENTAL)	P00240-01			1	1
	POWER CORD (WITH UK PLUG)	(UK)	P00241-01			1	1
	POWER CORD	(AUSTRALIA)	P00242-01			1	1
	POWER CORD	(CHINA)	P01960-01				1
30	LOUVER(B)	PP	1A0548-01			1	1
31	PUSH RETAINER	-	4A2414-01			3	3

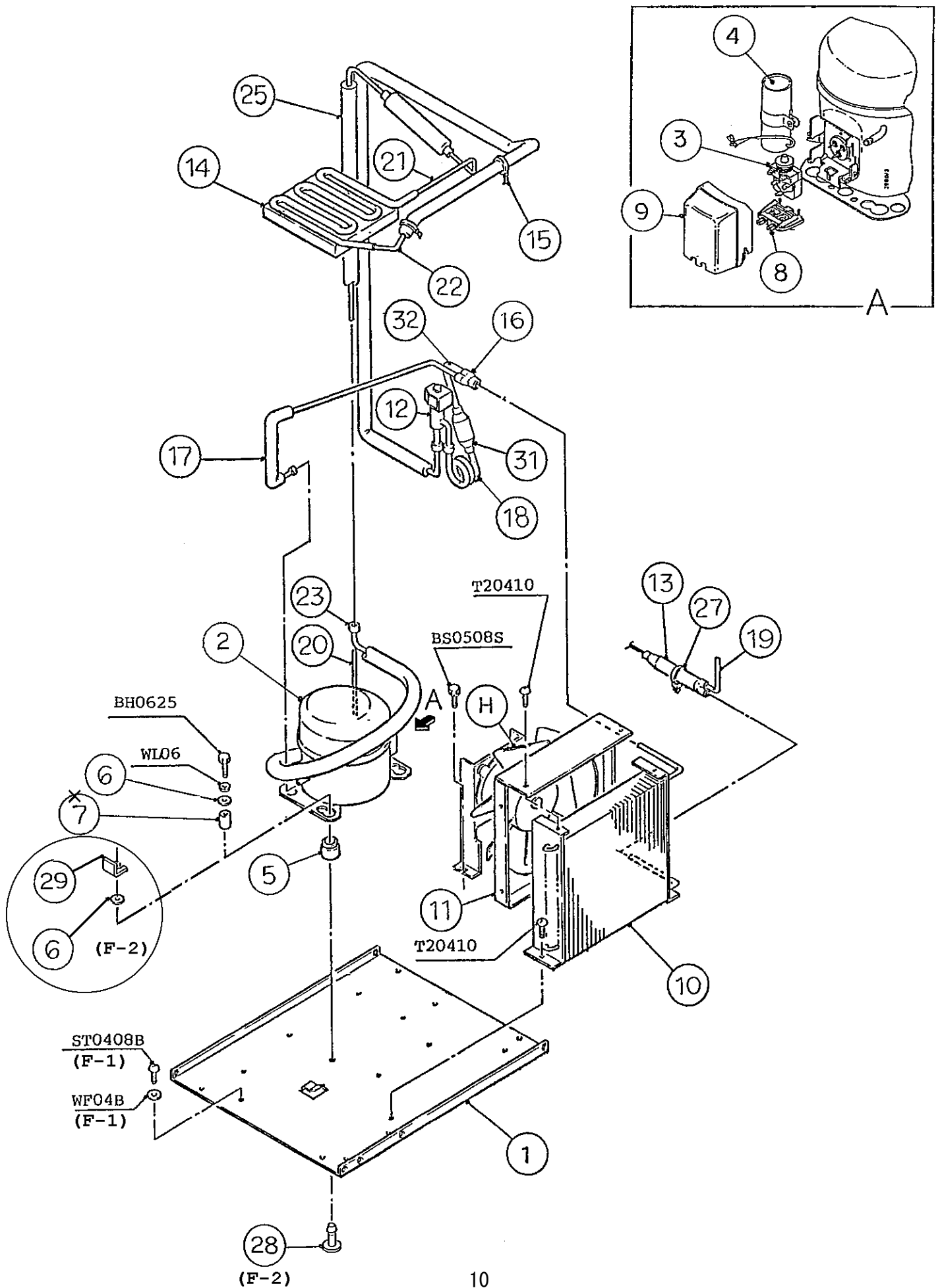

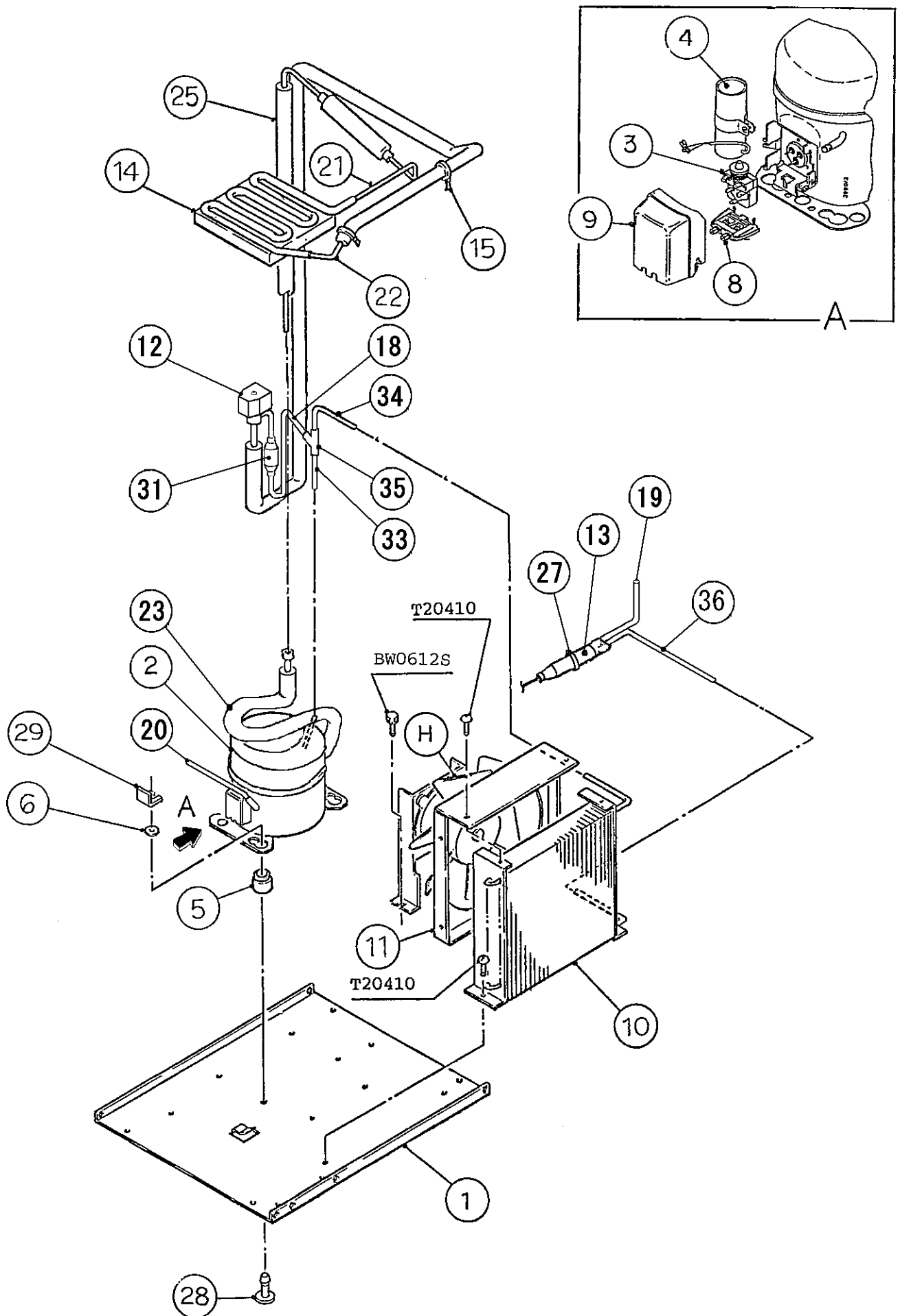

HE, GENERAL, OCEANIA, RINNAI, KOREA, AUSTRALIA, HSP, TAIWAN

MODEL : IM-45LE, IM-45LE-25				TITLE : B. REFRIGERATION UNIT			
INDEX NO.	DESCRIPTION	MATERIAL OR MODEL NUMBER	PART NUMBER	REQ'D NUMBER			
				F-1	F-2	G-1 H-0	H-1 J-0 K-0
H	FAN MOTOR ASSY	(S-0897)	3H2757A03	1	—		
		(S-0948)	3H9445A01		1	1	1
1	BASE	G.S	3H8178G03	1	1	—	
		G.S	3X0393G01			1	1
2	COMPRESSOR	FR8.5G	450891-01	1	1	1	1
	COMPRESSOR	FR8.5GX (TAIWAN)	4Y2667-01				
3	STARTING RELAY	117U6015	450893-01	1	1	1	1
	STARTING RELAY	117U4060 (TAIWAN)	4Y2668-01				
4	STARTING CAPACITOR	117U5015	450898-01	1	1	1	1
	STARTING CAPACITOR	117U5041 (TAIWAN)	4Y2669-01				
5	RUBBER GROMMET	-	450897-01	4	4	4	4
6	WASHER	-	450894-01	4	4	4	4
7	GROMMET SLEEVE	-	450895-01	4	x		
8	CORD RELIEF	103N1006	450899-01	1	1	1	1
9	COVER	103N2010	450896-01	1	1	1	1
	COVER	117U1021 (TAIWAN)	462715-01				
10	CONDENSER - AIR-COOLED	-	2H1066-01	1	1	1	1
			2H5655-01				
11	SHROUD	G.S	3H4539-01	1	1	1	1
12	HOT GAS SOLENOID VALVE	AMS-24B10HD-1	418866-02	1	1	1	1
13	DRIER	DY-15QHD-10	458773-01	1	1	1	1
		DY-12QHD-3	445655-04				
14	EVAPORATOR	(IM-45LE)	3H5611G01	1	1	1	—
			3H5611G02				1
	EVAPORATOR	(IM-45LE-25)	3H1681G01	1	1	1	—
			3H3941G01				1
15	TIE	CV-100	7920-0002	REQ'D	REQ'D	REQ'D	REQ'D
16	JOINT - G	COPPER	4X1092-07	1	1	x	
17	COPPER TUBE - HIGH SIDE	COPPER	3H8898G01	1	1	1	1
18	COPPER TUBE (A) - HOT GAS	COPPER	4X1292-01	1	1	—	
			4H7535-01			1	1
			4Y1168-01				
19	PROCESS TUBE (A)	COPPER	4H4351-01	1	1	1	1

HE, GENERAL, OCEANIA, RINNAI, KOREA, AUSTRALIA, HSP, TAIWAN

MODEL : IM-45LE, IM-45LE-25				TITLE : B. REFRIGERATION UNIT			
INDEX NO.	DESCRIPTION	MATERIAL OR MODEL NUMBER	PART NUMBER	REQ'D NUMBER			
				K-1,A-0 B-0,C-0	C-1 D-0	D-1	D-2 E-0
H	FAN MOTOR ASSY	-	-				
		(S-0948)	3H9445A01	1	1	1	1
1	BASE	G.S	3X0393G01	1	—		
			2H6017-01		1	1	1
2	COMPRESSOR	FR8.5G	450891-01	1	1	1	1
	COMPRESSOR	FR8.5GX (TAIWAN)	4Y2667-01				1
3	STARTING RELAY	117U6015	450893-01	1	1	1	1
	STARTING RELAY	117U4060 (TAIWAN)	4Y2668-01				1
4	STARTING CAPACITOR	117U5015	450898-01	1	1	1	1
	STARTING CAPACITOR	117U5041 (TAIWAN)	4Y2669-01				1
5	RUBBER GROMMET	-	450897-01	4	4	4	4
6	WASHER	-	450894-01	4	4	4	4
7	-	-	-				
8	CORD RELIEF	103N1006	450899-01	1	1	1	1
9	COVER	103N2010	450896-01	1	1	1	1
	COVER	117U1021 (TAIWAN)	462715-01				1
10	CONDENSER - AIR-COOLED	-	2H1066-01	1	—		
			2H5655-01		1	1	1
11	SHROUD	G.S	3H4539-01	1	1	1	1
12	HOT GAS SOLENOID VALVE	AMS-24B10HD-1	418866-02	1	1	1	1
13	DRIER	DY-15QHD-10	458773-01	1	1	1	1
		DY-12QHD-3	445655-04				
14	EVAPORATOR	(IM-45LE)	-				
			3H5611G02	1	1	1	1
14	EVAPORATOR	(IM-45LE-25)	-				
			3H3941G01	1	1	1	1
15	TIE	CV-100	7920-0002	REQ'D	REQ'D	REQ'D	REQ'D
16	-	-	-				
17	COPPER TUBE - HIGH SIDE	COPPER	3H8898G01	1	×		
18	COPPER TUBE (A) - HOT GAS	COPPER	-				
			4H7535-01	1	—		
			4Y1168-01		1	1	1
19	PROCESS TUBE (A)	COPPER	4H4351-01	1	1	1	1

HE, GENERAL, OCEANIA, RINNAI, KOREA, AUSTRALIA, HSP, TAIWAN, CHINA

MODEL : IM-45LE, IM-45LE-25				TITLE : B. REFRIGERATION UNIT			
INDEX NO.	DESCRIPTION	MATERIAL OR MODEL NUMBER	PART NUMBER	REQ'D NUMBER			
				E-1	E-2 R-0 S-0	S-1	S-2,T-0 U-0,V-0 L-0
H	FAN MOTOR ASSY	-	-				
		(S-0948)	3H9445A01	1	1	1	1
1	BASE	G.S	-				
			2H6017-01	1	1	1	1
2	COMPRESSOR	FR8.5G	450891-01	1	1	1	1
	COMPRESSOR	FR8.5GX (TAIWAN)	4Y2667-01	1	1	1	1
3	STARTING RELAY	117U6015	450893-01	1	1	1	1
	STARTING RELAY	117U4060 (TAIWAN)	4Y2668-01	1	1	1	1
4	STARTING CAPACITOR	117U5015	450898-01	1	1	1	1
	STARTING CAPACITOR	117U5041 (TAIWAN)	4Y2669-01	1	1	1	1
5	RUBBER GROMMET	-	450897-01	4	4	4	4
6	WASHER	-	450894-01	4	4	4	4
7	-	-	-				
8	CORD RELIEF	103N1006	450899-01	1	1	1	1
9	COVER	103N2010	450896-01	1	1	1	1
	COVER	117U1021 (TAIWAN)	462715-01	1	1	1	1
10	CONDENSER - AIR-COOLED	-	2H1066-01				
			2H5655-01	1	1	1	1
11	SHROUD	G.S	3H4539-01	1	1	1	1
12	HOT GAS SOLENOID VALVE	AMS-24B10HD-1	418866-02	1	1	1	1
13	DRIER	DY-15QHD-10	458773-01	1	—		
		DY-12QHD-3	445655-04		1	1	1
14	EVAPORATOR	(IM-45LE)	-				
			3H5611G02	1	1	1	1
14	EVAPORATOR	(IM-45LE-25)	-				
			3H3941G01	1	1	1	1
15	TIE	CV-100	7920-0002	REQ'D	REQ'D	REQ'D	REQ'D
16	-	-	-				
17	-	-	-				
18	COPPER TUBE (A) - HOT GAS	-	-				
		-	-				
		COPPER	4Y1168-01	1	1	1	1
19	PROCESS TUBE (A)	COPPER	4H4351-01	1	1	1	1

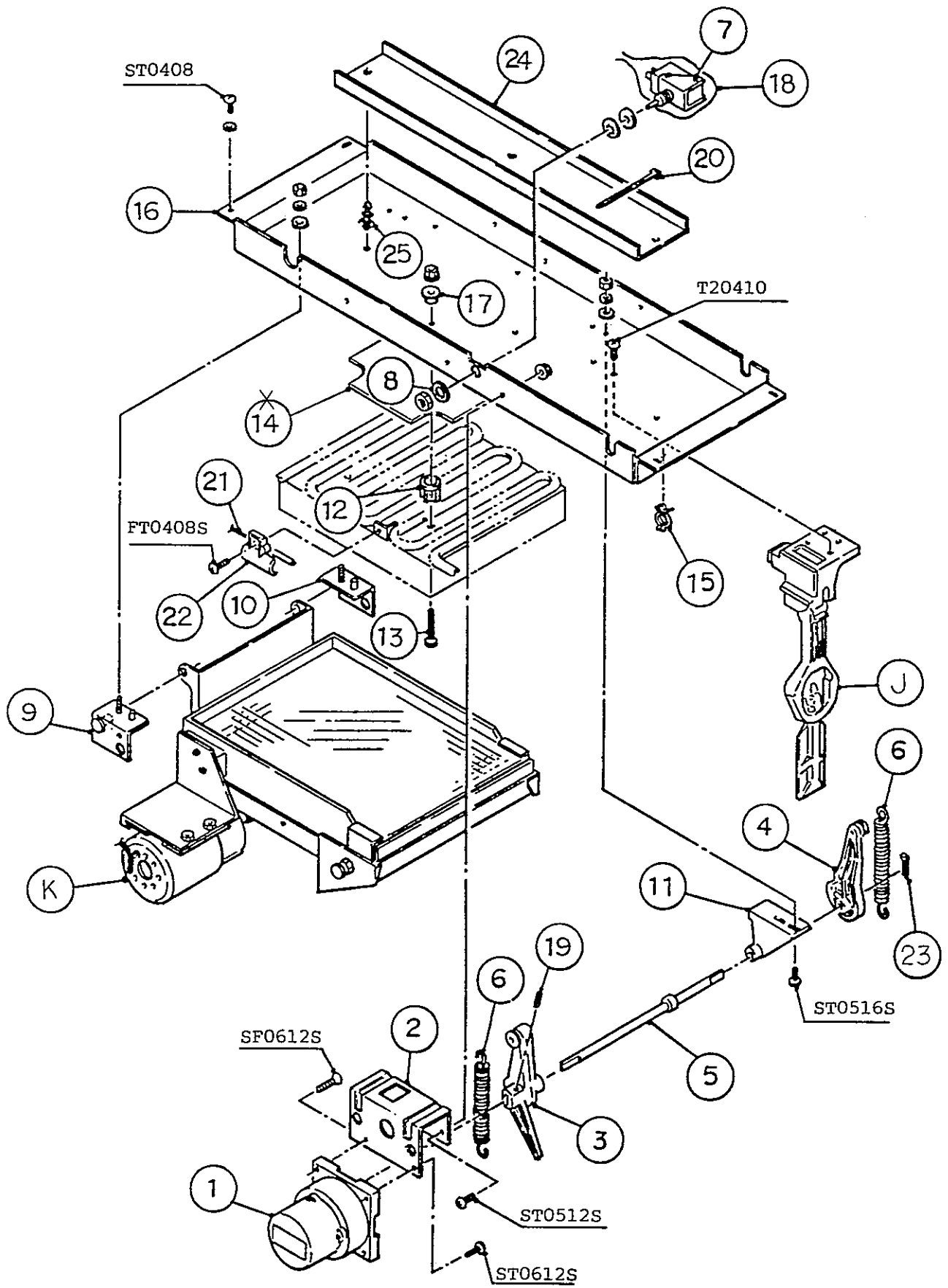

HE, GENERAL, OCEANIA, RINNAI, KOREA, AUSTRALIA, HSP, TAIWAN

MODEL : IM-45LE				TITLE : C. ICE MAKING MECHANISM ASSY			
INDEX NO.	DESCRIPTION	MATERIAL OR MODEL NUMBER	PART NUMBER	REQ'D NUMBER			
				F-1	F-2	G-1 H-0	H-1 J-0 K-0
J	BIN CONTROL SWITCH ASSY	(S-0817)	3H1537A02	1	1	1	1
K	WATER PAN ASSY	-	2H1158A01	1	-		
		-	2H1158A02		1	1	1
1	ACTUATOR MOTOR	SR65A41-13	452499-01	1	1	1	1
2	BRACKET - ACTUATOR MOTOR	G.S	3H1388-01	1	1	1	1
3	CAM (A)	AC	2H0659-01	1	1	1	1
4	CAM (B)	AC	3H1389-01	1	1	1	1
5	CAM SHAFT	S.S	4H2589G01	1	1	1	1
6	SPRING	S.S	4H2640-01	2	2	2	2
7	TOGGLE SWITCH	VAT4-71	431977-01	1	1	1	1
8	WASHER - TOGGLE SWITCH	S.S	406196-01	1	1	1	1
9	BEARING(FRONT) - WATER PAN	S.S	4H2591G02	1	1	1	1
10	BEARING(REAR) - WATER PAN	S.S	4H2592G02	1	1	1	1
11	CAM SHAFT HOLDER	ABS	307256-01	1	1	1	1
12	SPACER	AC	4H0471-01	4	4	4	4
13	SCREW - EVAPORATOR MOUNTING	S.S	4H2593-01	4	4	4	4
14	INSULATION - ICE MAKING MECHANISM BRACKET	PE	4H1153-01	1	1	1	1
15	CLAMP	No. 2674	427902-02	1	1	1	1
16	BRACKET - ICE MAKING MECHANISM	PAINTED STEEL	3H1405-01	1	1	-	
		PAINTED STEEL	3H9592-01			1	1
17	WASHER	AC	4H0777-01	4	4	4	4
18	SWITCH COVER	PE	408163-01	1	1	1	1
19	SPRING PIN	S.S, 3x22	712S-0322	1	1	1	1
20	TIE	CV-100	7920-0002	2	2	2	2
21	THERMISTOR	NBFC-36-AH1-3	462976-03	1	1	1	1
22	HOLDER - THERMISTOR	PE	315479-01	1	1	1	1
23	SPLIT PIN	S.S, 2x12	711S-0212	1	1	1	1
24	GUIDE - CONNECTOR	G.S	4H5618-01	1	1	1	1
25	BOARD SUPPORT	KGLS-4S	414929-02	3	3	3	3

HE, GENERAL, OCEANIA, RINNAI, KOREA, AUSTRALIA, HSP, TAIWAN

MODEL : IM-45LE				TITLE : C. ICE MAKING MECHANISM ASSY			
INDEX NO.	DESCRIPTION	MATERIAL OR MODEL NUMBER	PART NUMBER	REQ'D NUMBER			
				K-1,A-0 B-0,C-0	C-1 D-0	D-1	D-2 E-0
J	BIN CONTROL SWITCH ASSY	(S-0817)	3H1537A02	1	1	1	1
K	WATER PAN ASSY	-	-				
		-	2H1158A05	1	1	1	1
1	ACTUATOR MOTOR	SR65A41-13	452499-01	1	1	1	1
2	BRACKET - ACTUATOR MOTOR	G.S	3H1388-01	1	1	1	1
3	CAM (A)	AC	2H0659-01	1	1	1	1
4	CAM (B)	AC	3H1389-01	1	1	1	1
5	CAM SHAFT	S.S	4H2589G01	1	1	1	1
6	SPRING	S.S	4H2640-01	2	2	2	2
7	TOGGLE SWITCH	VAT4-71	431977-01	1	1	1	1
8	WASHER - TOGGLE SWITCH	S.S	406196-01	1	1	1	1
9	BEARING(FRONT) - WATER PAN	S.S	4H2591G02	1	1	1	1
10	BEARING(REAR) - WATER PAN	S.S	4H2592G02	1	1	1	1
11	CAM SHAFT HOLDER	ABS	307256-01	1	1	1	1
12	SPACER	AC	4H0471-01	4	4	4	4
13	SCREW - EVAPORATOR MOUNTING	S.S	4H2593-01	4	4	4	4
14	INSULATION - ICE MAKING MECHANISM BRACKET	PE	4H1153-01	×			
15	CLAMP	No. 2674	427902-02	1	1	1	1
16	BRACKET - ICE MAKING MECHANISM	-	-				
		PAINTED STEEL	3H9592-01	1	1	1	1
17	WASHER	AC	4H0777-01	4	4	4	4
18	SWITCH COVER	PE	408163-01	1	1	1	1
19	SPRING PIN	S.S, 3x22	712S-0322	1	1	1	1
20	TIE	CV-100	7920-0002	2	2	2	2
21	THERMISTOR	NBFC-36-AH1-3	462976-03	1	1	1	1
22	HOLDER - THERMISTOR	PE	315479-01	1	1	1	1
23	SPLIT PIN	S.S, 2x12	711S-0212	1	1	1	1
24	GUIDE - CONNECTOR	G.S	4H5618-01	1	1	1	1
25	BOARD SUPPORT	KGLS-4S	414929-02	3	3	3	3

HE, GENERAL, OCEANIA, RINNAI, KOREA, AUSTRALIA, HSP, TAIWAN, CHINA

MODEL : IM-45LE				TITLE : C. ICE MAKING MECHANISM ASSY			
INDEX NO.	DESCRIPTION	MATERIAL OR MODEL NUMBER	PART NUMBER	REQ'D NUMBER			
				E-1	E-2 R-0 S-0	S-1	S-2,T-0 U-0,V-0 L-0
J	BIN CONTROL SWITCH ASSY	(S-0817)	3H1537A02	1	1	1	1
K	WATER PAN ASSY	-	-				
		-	2H1158A05	1	1	1	1
1	ACTUATOR MOTOR	SR65A41-13	452499-01	1	1	1	1
2	BRACKET - ACTUATOR MOTOR	G.S	3H1388-01	1	1	1	1
3	CAM (A)	AC	2H0659-01	1	1	1	1
4	CAM (B)	AC	3H1389-01	1	1	1	1
5	CAM SHAFT	S.S	4H2589G01	1	1	1	1
6	SPRING	S.S	4H2640-01	2	2	2	2
7	TOGGLE SWITCH	VAT4-71	431977-01	1	1	1	1
8	WASHER - TOGGLE SWITCH	S.S	406196-01	1	1	1	1
9	BEARING(FRONT) - WATER PAN	S.S	4H2591G02	1	1	1	1
10	BEARING(REAR) - WATER PAN	S.S	4H2592G02	1	1	1	1
11	CAM SHAFT HOLDER	ABS	307256-01	1	1	1	1
12	SPACER	AC	4H0471-01	4	4	4	4
13	SCREW - EVAPORATOR MOUNTING	S.S	4H2593-01	4	4	4	4
14	-	-	-				
15	CLAMP	No. 2674	427902-02	1	1	1	1
16	BRACKET - ICE MAKING MECHANISM	-	-				
		PAINTED STEEL	3H9592-01	1	1	1	1
17	WASHER	AC	4H0777-01	4	4	4	4
18	SWITCH COVER	PE	408163-01	1	1	1	1
19	SPRING PIN	S.S, 3x22	712S-0322	1	1	1	1
20	TIE	CV-100	7920-0002	2	2	2	2
21	THERMISTOR	NBFC-36-AH1-3	462976-03	1	1	1	1
22	HOLDER - THERMISTOR	PE	315479-01	1	1	1	1
23	SPLIT PIN	S.S, 2x12	711S-0212	1	1	1	1
24	GUIDE - CONNECTOR	G.S	4H5618-01	1	1	1	1
25	BOARD SUPPORT	KGLS-4S	414929-02	3	3	3	3

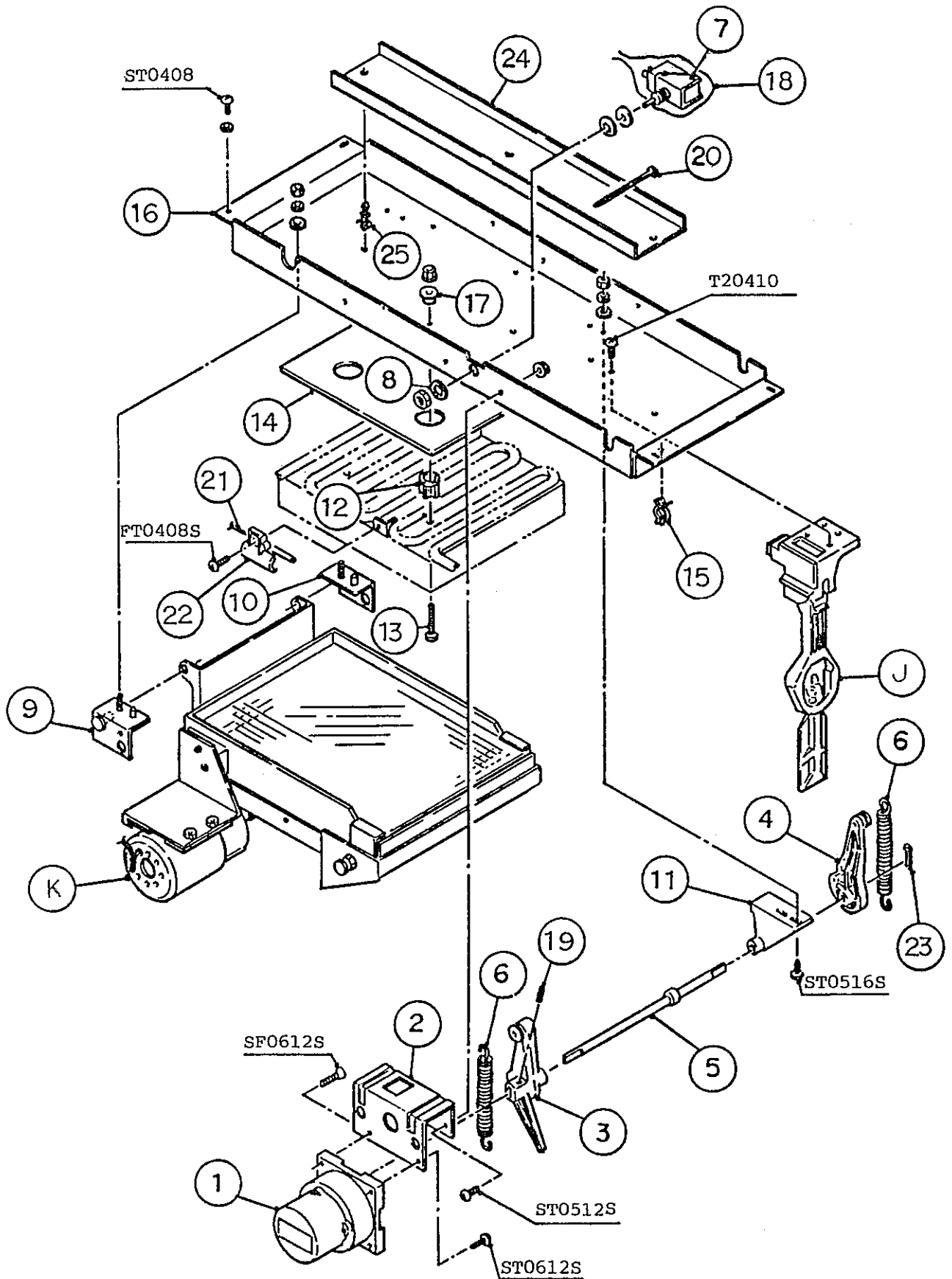

HE, GENERAL, OCEANIA, RINNAI, KOREA, AUSTRALIA, HSP, TAIWAN

MODEL : IM-45LE-25				TITLE : C. ICE MAKING MECHANISM ASSY			
INDEX NO.	DESCRIPTION	MATERIAL OR MODEL NUMBER	PART NUMBER	REQ'D NUMBER			
				F-1	F-2	G-1 H-0	H-1 J-0 K-0
J	BIN CONTROL SWITCH ASSY	(S-0817)	3H1537A02	1	1	1	1
K	WATER PAN ASSY	-	-	1	1	1	1
1	ACTUATOR MOTOR	SR65A41-13	452499-01	1	1	1	1
2	BRACKET - ACTUATOR MOTOR	G.S	3H1388-01	1	1	1	1
3	CAM (A)	AC	2H0659-01	1	1	1	1
4	CAM (B)	AC	3H1389-01	1	1	1	1
5	CAM SHAFT	S.S	4X1458G02	1	1	1	1
6	SPRING	S.S	4H2640-01	2	2	2	2
7	TOGGLE SWITCH	VAT4-71	431977-01	1	1	1	1
8	WASHER - TOGGLE SWITCH	S.S	406196-01	1	1	1	1
9	BEARING(FRONT) - WATER PAN	S.S	4H2591G02	1	1	1	1
10	BEARING(REAR) - WATER PAN	S.S	4H2592G02	1	1	1	1
11	CAM SHAFT HOLDER	ABS	307256-01	1	1	1	1
12	SPACER	AC	4X5342-01	4	4	4	4
13	SCREW EVAPORATOR	S.S	4Y4922M02	4	4	4	4
14	INSULATION - ICE MAKING MECHANISM BRACKET	PE	4H1467-01	1	1	1	1
15	CLAMP	No. 2674	427902-02	1	1	1	1
16	BRACKET - ICE MAKING MECHANISM	PAINTED STEEL	3H1680-01	1	1	—	
		PAINTED STEEL	3H9650-01			1	1
17	WASHER	AC	4H0777-01	4	4	4	4
18	COVER - THERMISTOR	PE	408163-01	1	1	1	1
19	SPRING PIN	S.S, 3x22	712S-0322	1	1	1	1
20	TIE	CV-100	7920-0002	2	2	2	2
21	THERMISTOR	NBFC-36-AH1-3	462976-03	1	1	1	1
22	HOLDER - THERMISTOR	PE	315479-01	1	1	1	1
23	SPLIT PIN	S.S, 2x12	711S-0212	1	1	1	1
24	GUIDE - CONNECTOR	G.S	4H5618-01	1	1	1	1
25	BOARD SUPPORT	KGLS-4S	414929-02	3	3	3	3

HE, GENERAL, OCEANIA, RINNAI, KOREA, AUSTRALIA, HSP, TAIWAN

MODEL : IM-45LE-25				TITLE : C. ICE MAKING MECHANISM ASSY			
INDEX NO.	DESCRIPTION	MATERIAL OR MODEL NUMBER	PART NUMBER	REQ'D NUMBER			
				K-1,A-0 B-0,C-0	C-1 D-0	D-1	D-2 E-0
J	BIN CONTROL SWITCH ASSY	(S-0817)	3H1537A02	1	1	1	1
K	WATER PAN ASSY	-	-	1	1	1	1
1	ACTUATOR MOTOR	SR65A41-13	452499-01	1	1	1	1
2	BRACKET - ACTUATOR MOTOR	G.S	3H1388-01	1	1	1	1
3	CAM (A)	AC	2H0659-01	1	1	1	1
4	CAM (B)	AC	3H1389-01	1	1	1	1
5	CAM SHAFT	S.S	4X1458G02	1	1	1	1
6	SPRING	S.S	4H2640-01	2	2	2	2
7	TOGGLE SWITCH	VAT4-71	431977-01	1	1	1	1
8	WASHER - TOGGLE SWITCH	S.S	406196-01	1	1	1	1
9	BEARING(FRONT) - WATER PAN	S.S	4H2591G02	1	1	1	1
10	BEARING(REAR) - WATER PAN	S.S	4H2592G02	1	1	1	1
11	CAM SHAFT HOLDER	ABS	307256-01	1	1	1	1
12	SPACER	AC	4X5342-01	4	4	4	4
13	SCREW EVAPORATOR	S.S	4Y4922M02	4	4	4	4
14	INSULATION - ICE MAKING MECHANISM BRACKET	PE	4H1467-01	1	1	1	1
15	CLAMP	No. 2674	427902-02	1	1	1	1
16	BRACKET - ICE MAKING MECHANISM	-	-				
		PAINTED STEEL	3H9650-01	1	1	1	1
17	WASHER	AC	4H0777-01	4	4	4	4
18	COVER - THERMISTOR	PE	408163-01	1	1	1	1
19	SPRING PIN	S.S, 3x22	712S-0322	1	1	1	1
20	TIE	CV-100	7920-0002	2	2	2	2
21	THERMISTOR	NBFC-36-AH1-3	462976-03	1	1	1	1
22	HOLDER - THERMISTOR	PE	315479-01	1	1	1	1
23	SPLIT PIN	S.S, 2x12	711S-0212	1	1	1	1
24	GUIDE - CONNECTOR	G.S	4H5618-01	1	1	1	1
25	BOARD SUPPORT	KGLS-4S	414929-02	3	3	3	3

HE, GENERAL, OCEANIA, RINNAI, KOREA, AUSTRALIA, HSP, TAIWAN, CHINA

MODEL : IM-45LE-25				TITLE : C. ICE MAKING MECHANISM ASSY			
INDEX NO.	DESCRIPTION	MATERIAL OR MODEL NUMBER	PART NUMBER	REQ'D NUMBER			
				E-1	E-2 R-0 S-0	S-1	S-2,T-0 U-0,V-0 L-0
J	BIN CONTROL SWITCH ASSY	(S-0817)	3H1537A02	1	1	1	1
K	WATER PAN ASSY	-	-	1	1	1	1
1	ACTUATOR MOTOR	SR65A41-13	452499-01	1	1	1	1
2	BRACKET - ACTUATOR MOTOR	G.S	3H1388-01	1	1	1	1
3	CAM (A)	AC	2H0659-01	1	1	1	1
4	CAM (B)	AC	3H1389-01	1	1	1	1
5	CAM SHAFT	S.S	4X1458G02	1	1	1	1
6	SPRING	S.S	4H2640-01	2	2	2	2
7	TOGGLE SWITCH	VAT4-71	431977-01	1	1	1	1
8	WASHER - TOGGLE SWITCH	S.S	406196-01	1	1	1	1
9	BEARING(FRONT) - WATER PAN	S.S	4H2591G02	1	1	1	1
10	BEARING(REAR) - WATER PAN	S.S	4H2592G02	1	1	1	1
11	CAM SHAFT HOLDER	ABS	307256-01	1	1	1	1
12	SPACER	AC	4X5342-01	4	4	4	4
13	SCREW EVAPORATOR	S.S	4Y4922M02	4	4	4	4
14	INSULATION - ICE MAKING MECHANISM BRACKET	PE	4H1467-01	1	1	1	1
15	CLAMP	No. 2674	427902-02	1	1	1	1
16	BRACKET - ICE MAKING MECHANISM	-	-				
		PAINTED STEEL	3H9650-01	1	1	1	1
17	WASHER	AC	4H0777-01	4	4	4	4
18	COVER - THERMISTOR	PE	408163-01	1	1	1	1
19	SPRING PIN	S.S, 3x22	712S-0322	1	1	1	1
20	TIE	CV-100	7920-0002	2	2	2	2
21	THERMISTOR	NBFC-36-AH1-3	462976-03	1	1	1	1
22	HOLDER - THERMISTOR	PE	315479-01	1	1	1	1
23	SPLIT PIN	S.S, 2x12	711S-0212	1	1	1	1
24	GUIDE - CONNECTOR	G.S	4H5618-01	1	1	1	1
25	BOARD SUPPORT	KGLS-4S	414929-02	3	3	3	3

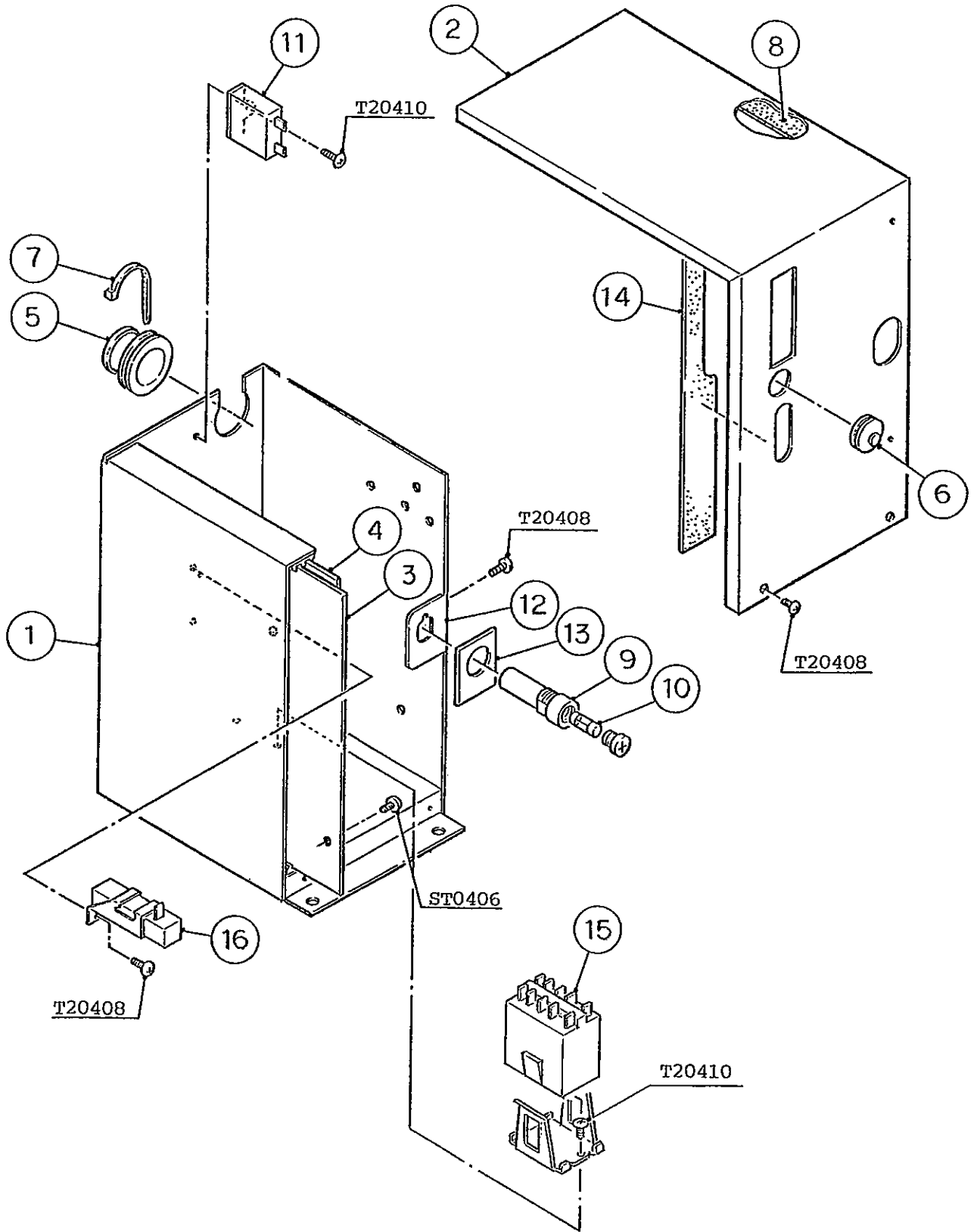

IM-45LE
IM-45LE-25

D. CONTROL BOX ASSY

(D-1) (D-2) (E-0)
(B-0) (C-0) (C-1) (D-0)
(J-0) (K-0) (K-1) (A-0)
(F-2) (G-1) (H-0) (H-1)

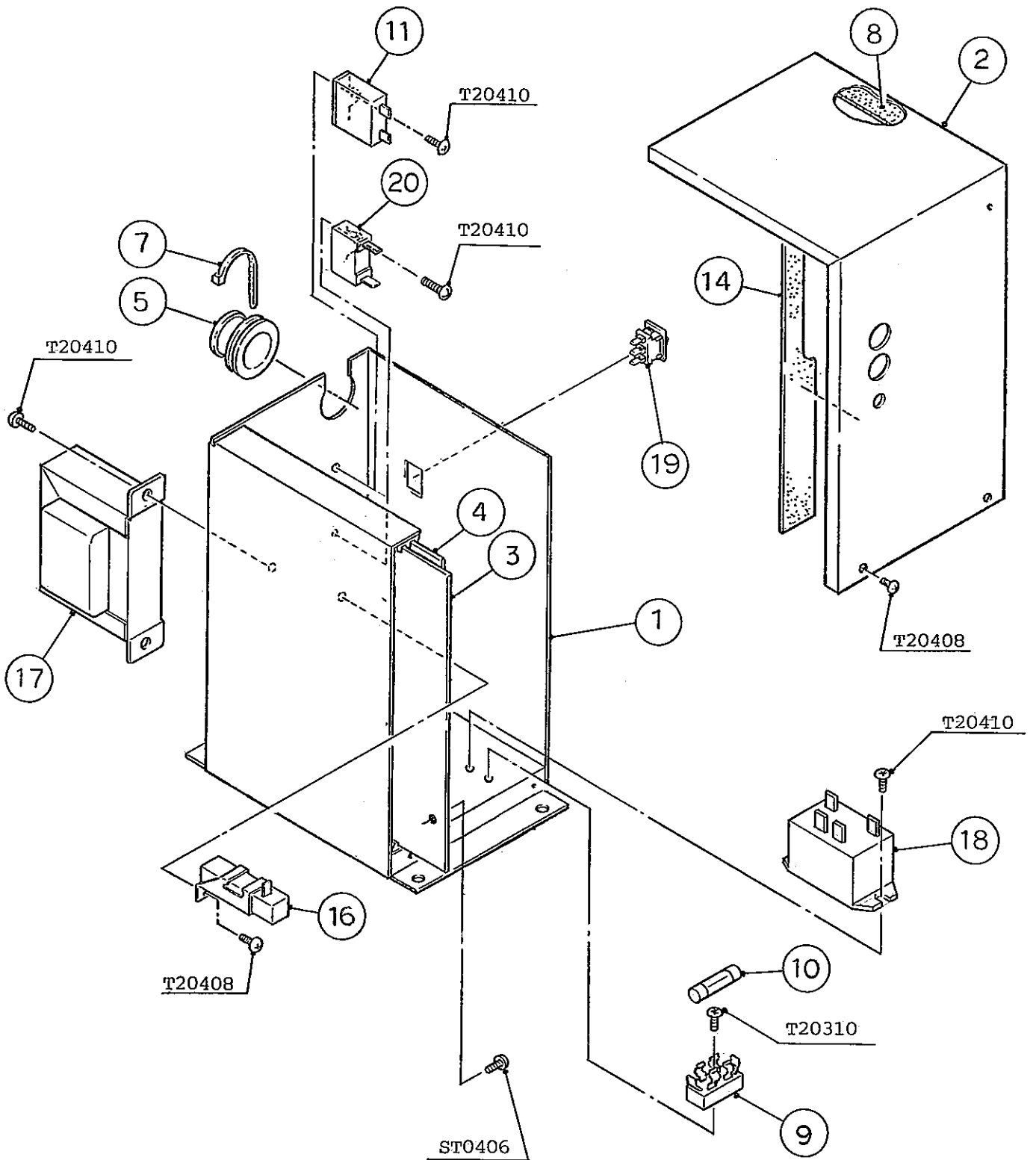

IM-45LE
IM-45LE-25

D. CONTROL BOX ASSY

(E-1) and later

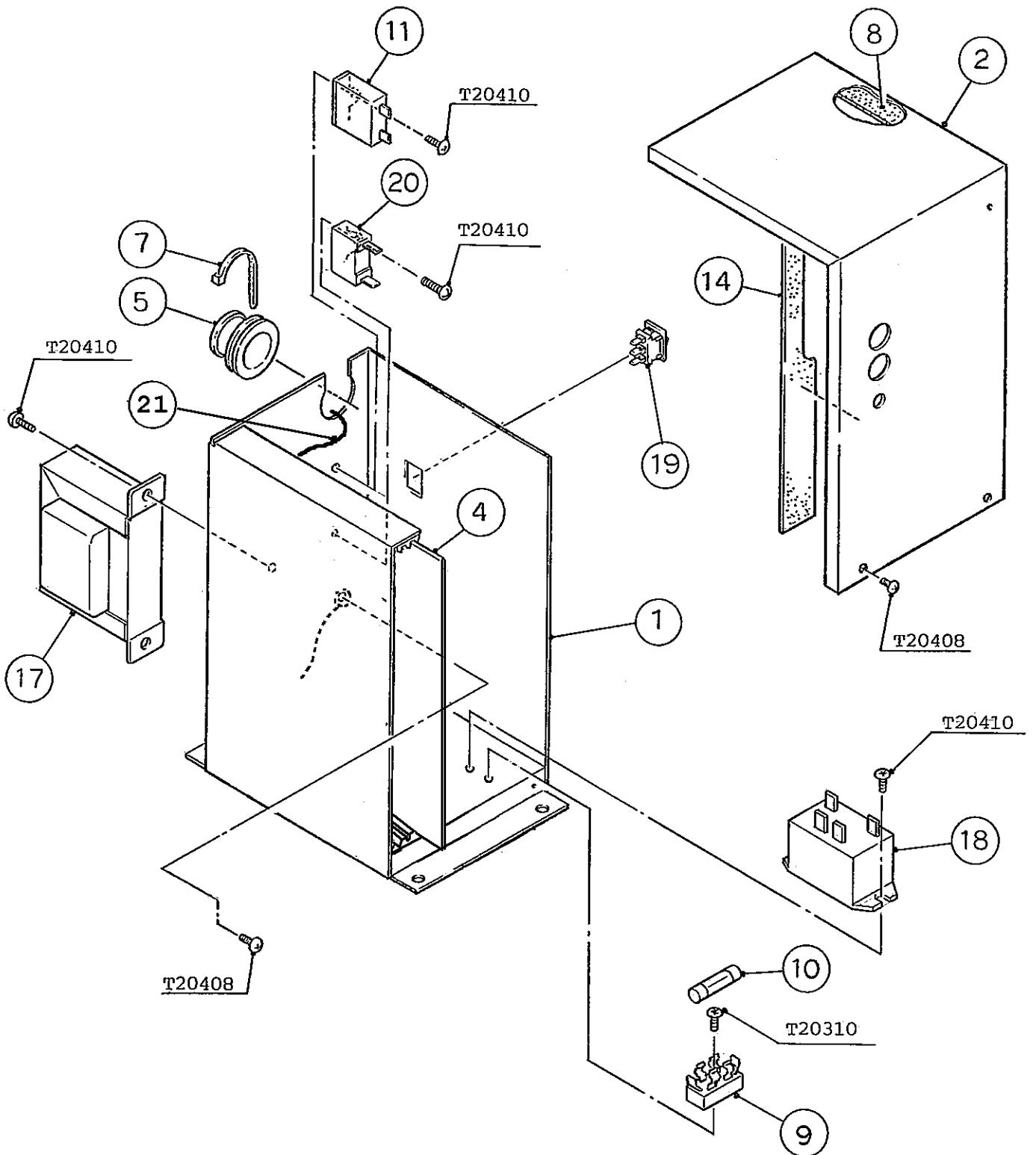

HE, GENERAL, OCEANIA, RINNAI, KOREA, AUSTRALIA, HSP, TAIWAN

MODEL : IM-45LE, IM-45LE-25				TITLE : D. CONTROL BOX ASSY			
INDEX NO.	DESCRIPTION	MATERIAL OR MODEL NUMBER	PART NUMBER	REQ'D NUMBER			
				F-1	F-2	G-1 H-0	H-1 J-0 K-0
1	CONTROL BOX	G.S	3H9136A01	1	—		
		G.S	3H9453G01		1	1	—
		G.S	3H9453G02				1
		G.S	3H9453G04				
2	CONTROL BOX COVER	G.S	4H2623-01	1	—		
		G.S	3H9456-01		1	1	1
3	SHIELD PLATE	G.S	4H2594-01	1	1	1	1
4	CONTROLLER BOARD	H2AA136C10	436572-10	1	1	1	1
		H2AE024C18	462975-18				
5	GROMMET	NBR	4H2568-01	1	1	1	1
6	GROMMET - PUSH	-	4H2596-01	1	x		
7	NYLON TIE	PRT1.5S	427466-10	1	1	1	1
8	TAPE	w8 x t3.2	2H3209-09	1	1	1	1
		w8 x t3.2	2H6762-06				
9	FUSE HOLDER	FH032, 250V10A	424288-01	1	—		
		445710	451925-01		1	1	1
10	FUSE	5A, 125V	406519-03	1	—		
		5A	451924-01		1	1	1
11	CAPACITOR - ACTUATOR MOTOR	2.0uF	416921-08	1	—		
		0.8uF	416969-01		1	1	1
12	BRACKET - FUSE HOLDER	G.S	4H2597-01	1	x		
13	PACKING	PE FOAM	4H2644-01	1	x		
14	CUSHION	25 x 210 x 2.5t, PE	4H2718-01	1	1	1	1
15	MAGNETIC CONTACTOR	FMC-OTZ15-40	415856-03	1	x		
16	SURGE ABSORBER	-	436573-02	1	1	1	1
17	TRANSFORMER	230V / 100V	450104-01		1	1	1
18	POWER RELAY	G7L-1A-TUB	449000-01		1	1	1
19	ROCKER SWITCH	H8600VB	460681-01				1

HE, GENERAL, OCEANIA, RINNAI, KOREA, AUSTRALIA, HSP, TAIWAN

MODEL : IM-45LE, IM-45LE-25		TITLE : D. CONTROL BOX ASSY					
INDEX NO.	DESCRIPTION	MATERIAL OR MODEL NUMBER	PART NUMBER	REQ'D NUMBER			
				K-1,A-0 B-0,C-0	C-1 D-0	D-1	D-2 E-0
1	CONTROL BOX	-	-				
		-	-				
		G.S	3H9453G02	1	1	1	-
		G.S	3H9453G04				1
2	CONTROL BOX COVER	-	-				
		G.S	3H9456-01	1	1	1	1
3	SHIELD PLATE	G.S	4H2594-01	1	1	1	1
4	CONTROLLER BOARD	H2AA136C10	436572-10	1	1	1	1
		H2AE024C18	462975-18				
5	GROMMET	NBR	4H2568-01	1	1	1	1
6	-	-	-				
7	NYLON TIE	PRT1.5S	427466-10	1	1	1	1
8	TAPE	w8 x t3.2	2H3209-09	1	1	1	1
		w8 x t3.2	2H6762-06				
9	FUSE HOLDER	445710	451925-01	1	1	1	-
		CFH15	4Y2547-01				1
10	FUSE	5A	451924-01	1	1	1	1
		10A (TAIWAN)	451924-03				1
11	CAPACITOR - ACTUATOR MOTOR	0.8uF	416969-01	1	1	1	1
12	-	-	-				
13	-	-	-				
14	CUSHION	25 x 210 x 2.5t, PE	4H2718-01	1	1	1	1
15	-	-	-				
16	SURGE ABSORBER	-	436573-02	1	1	1	1
17	TRANSFORMER	230V / 100V	450104-01	1	1	1	1
	TRANSFORMER	115V/100V (TAIWAN)	4Y2666-01				1
18	POWER RELAY	G7L-1A-TUB	449000-01	1	1	1	1
19	ROCKER SWITCH	H8600VB	460681-01	1	1	1	1
20	CAPACITOR - PUMP MOTOR	1.0uF	457885-01	1	1	1	1

HE, GENERAL, OCEANIA, RINNAI, KOREA, AUSTRALIA, HSP, TAIWAN, CHINA

MODEL : IM-45LE, IM-45LE-25				TITLE : D. CONTROL BOX ASSY			
INDEX NO.	DESCRIPTION	MATERIAL OR MODEL NUMBER	PART NUMBER	REQ'D NUMBER			
				E-1	E-2 R-0 S-0	S-1	S-2,T-0 U-0,V-0 L-0
1	CONTROL BOX	-	-				
		-	-				
		-	-				
		G.S	3H9453G04	1	1	1	1
2	CONTROL BOX COVER	-	-				
		G.S	3H9456-01	1	1	1	1
3	SHIELD PLATE	G.S	4H2594-01	x			
4	CONTROLLER BOARD	H2AA136C10	436572-10	-			
		H2AE024C18	462975-18	1	1	1	1
5	GROMMET	NBR	4H2568-01	1	1	1	1
6	-	-	-				
7	NYLON TIE	PRT1.5S	427466-10	1	1	1	1
8	TAPE	w8 x t3.2	2H3209-09	-			
		w8 x t3.2	2H6762-06	1	1	1	1
9	FUSE HOLDER	-	-				
		CFH15	4Y2547-01	1	1	1	1
10	FUSE	5A	451924-01	1	1	1	1
		10A (TAIWAN)	451924-03	1	1	1	1
11	CAPACITOR - ACTUATOR MOTOR	0.8uF	416969-01	1	1	1	1
12	-	-	-				
13	-	-	-				
14	CUSHION	25 x 210 x 2.5t, PE	4H2718-01	1	1	1	1
15	-	-	-				
16	SURGE ABSORBER	-	436573-02	x			
17	TRANSFORMER	230V / 100V	450104-01	1	1	1	1
	TRANSFORMER	115V/100V (TAIWAN)	4Y2666-01	1	1	1	1
18	POWER RELAY	G7L-1A-TUB	449000-01	1	1	1	1
19	ROCKER SWITCH	H8600VB	460681-01	1	1	1	1
20	CAPACITOR - PUMP MOTOR	1.0uF	457885-01	1	1	1	1
21	THERMISTOR-AMBIENT TEMP	182-103-86742	462977-02	1	1	1	1

IM-45LE
IM-45LE-25

E. DOOR ASSY

(E-1) (E-2) (R-0) (S-0)
(D-0) (D-1) (D-2) (E-0)
(A-0) (B-0) (C-0) (C-1)
(H-1) (J-0) (K-0) (K-1)
(F-1) (F-2) (G-1) (H-0)

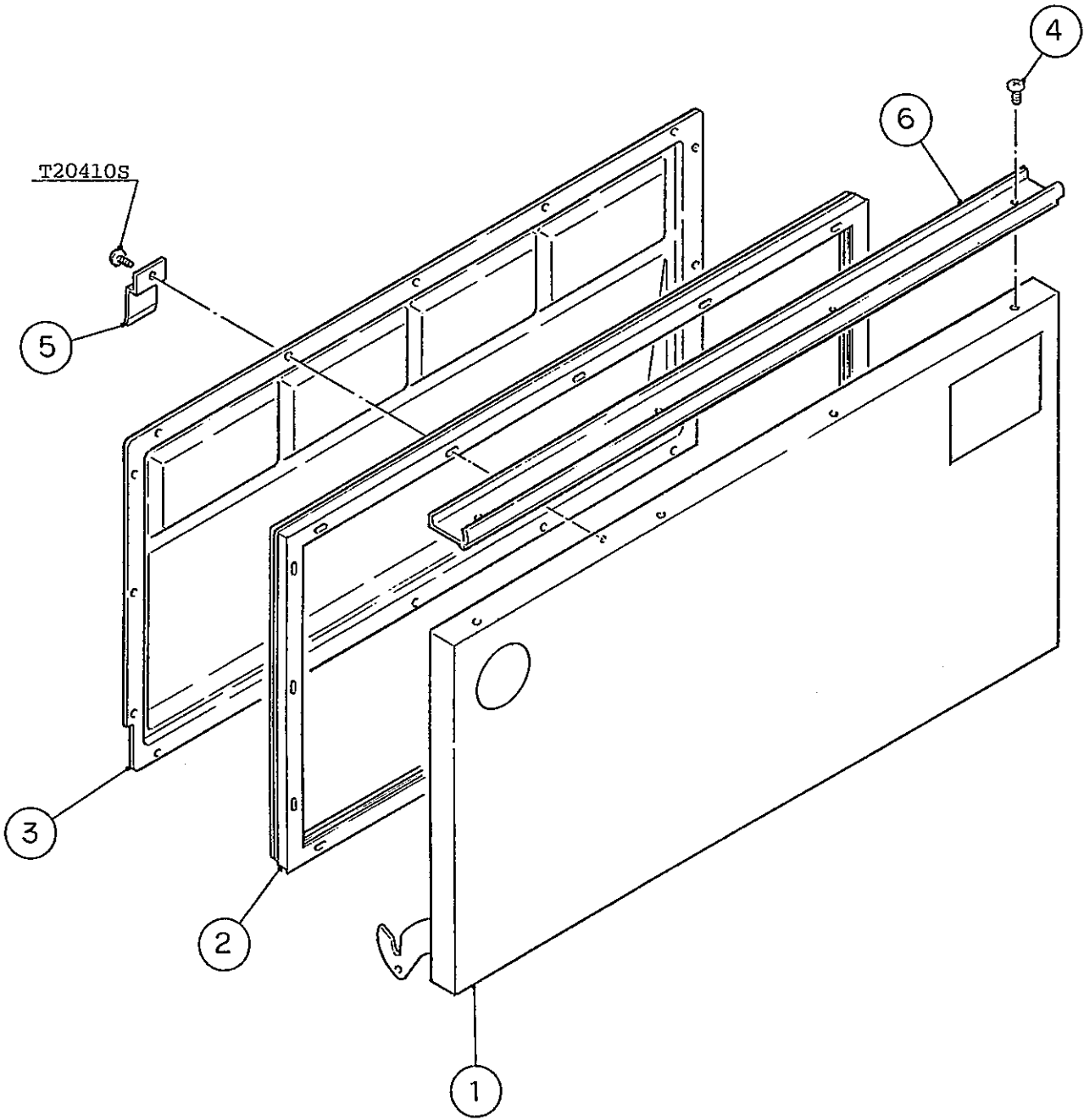

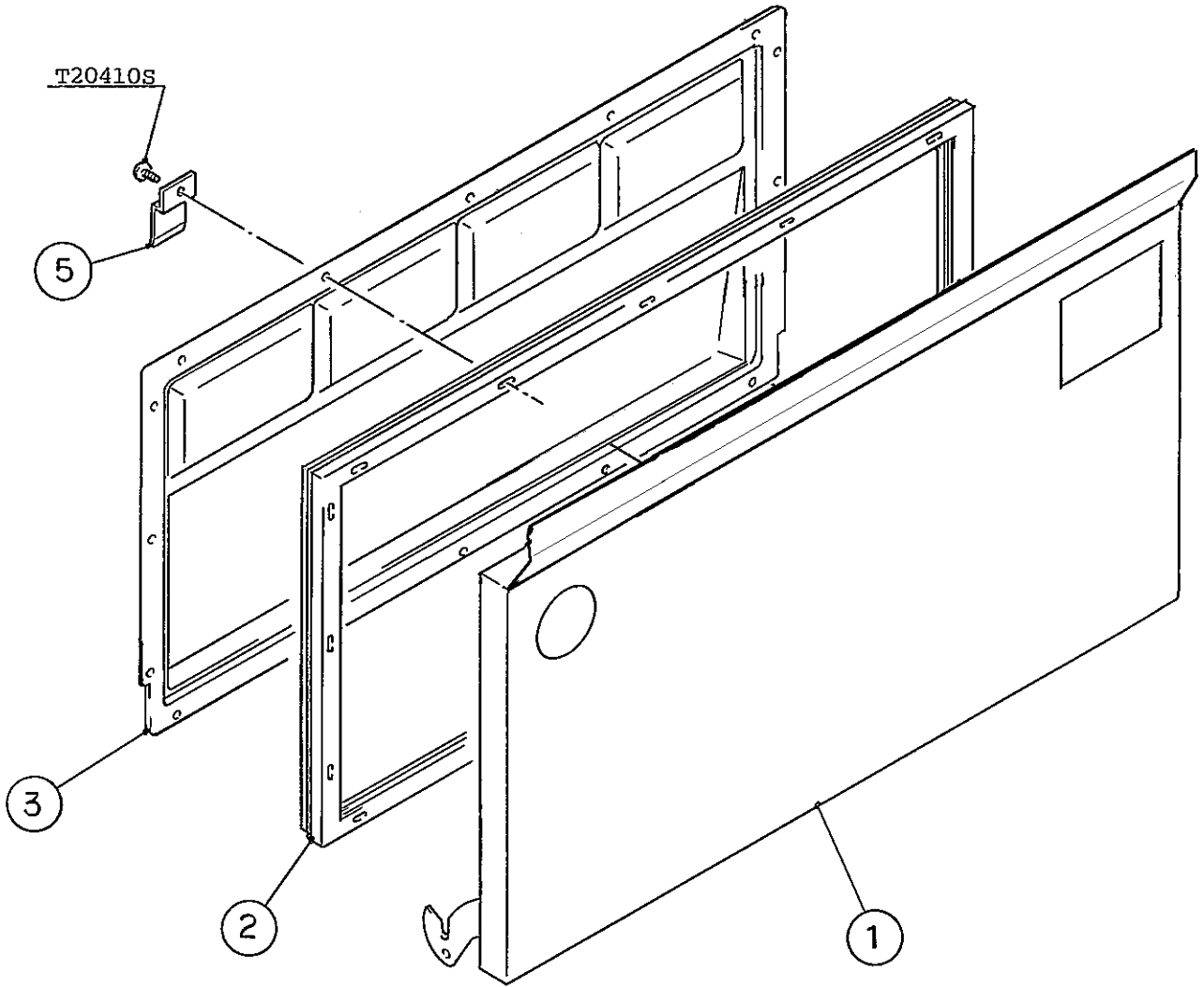

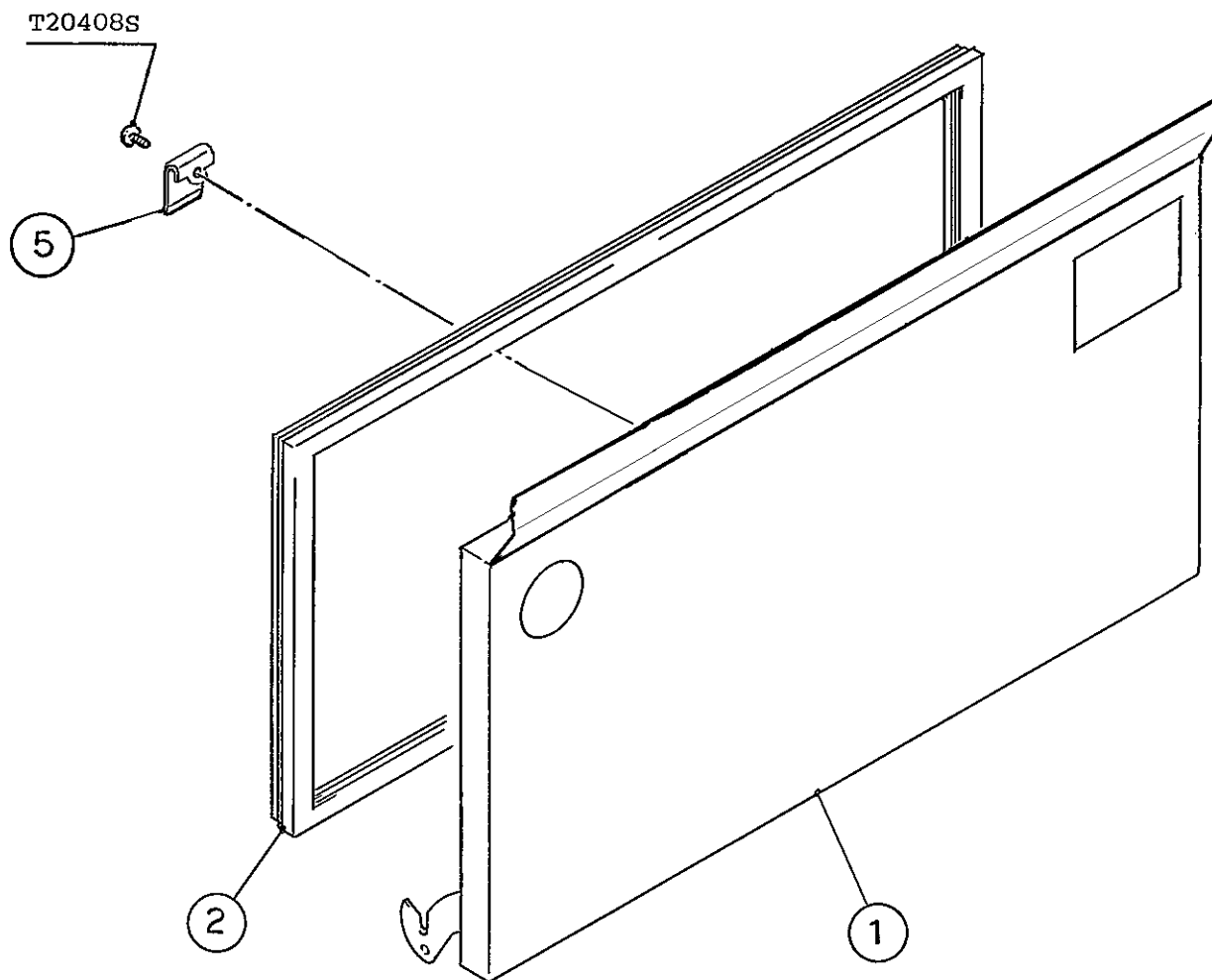

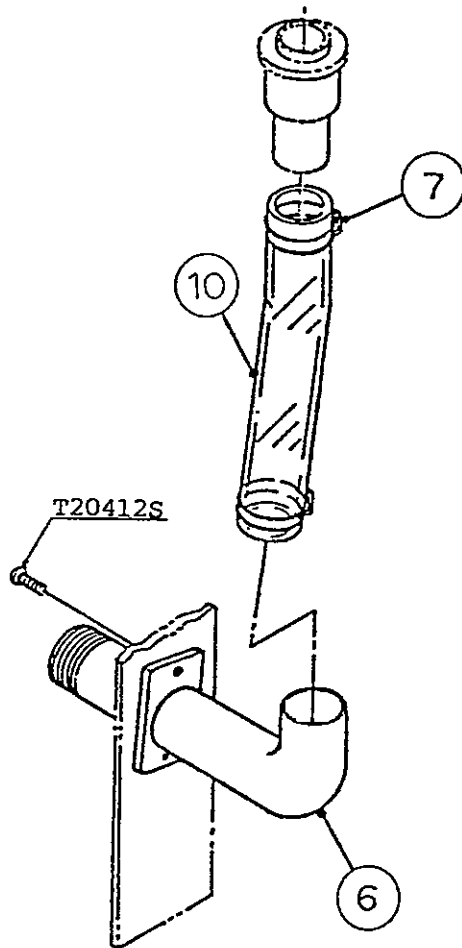
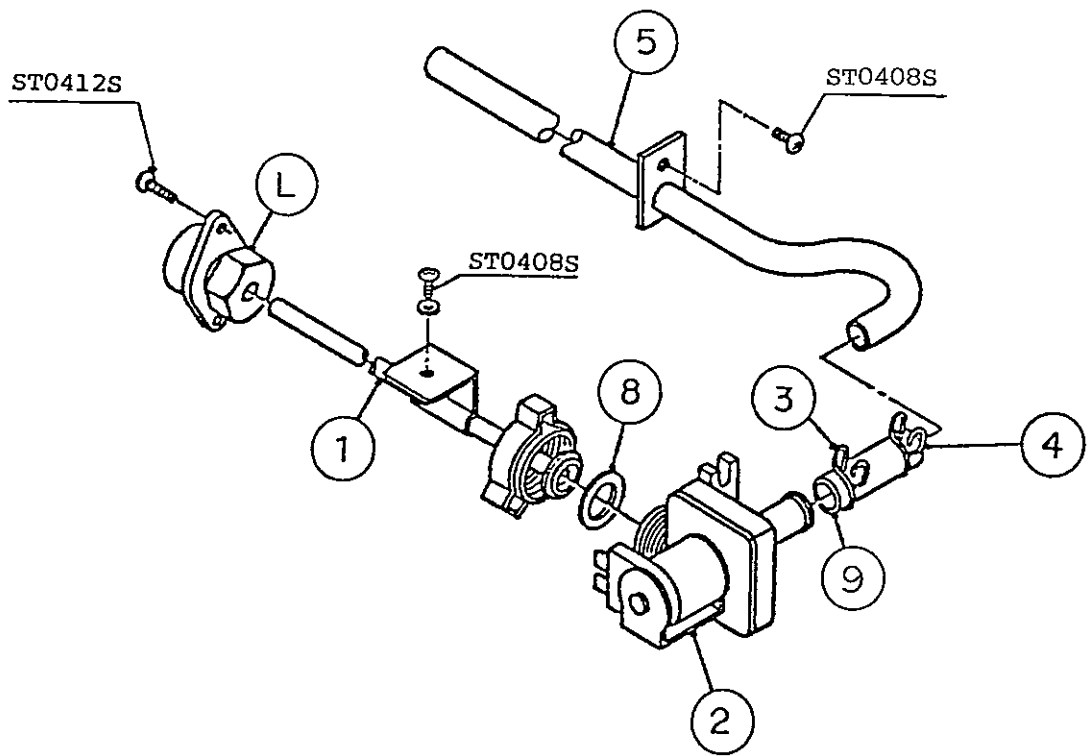

IM-45LE
IM-45LE-25

F. WATER CIRCUIT ASSY

(D-2) (E-0) (E-1) and later
(C-0) (C-1) (D-0) (D-1)
(K-0) (K-1) (A-0) (B-0)
(G-1) (H-0) (H-1) (J-0)

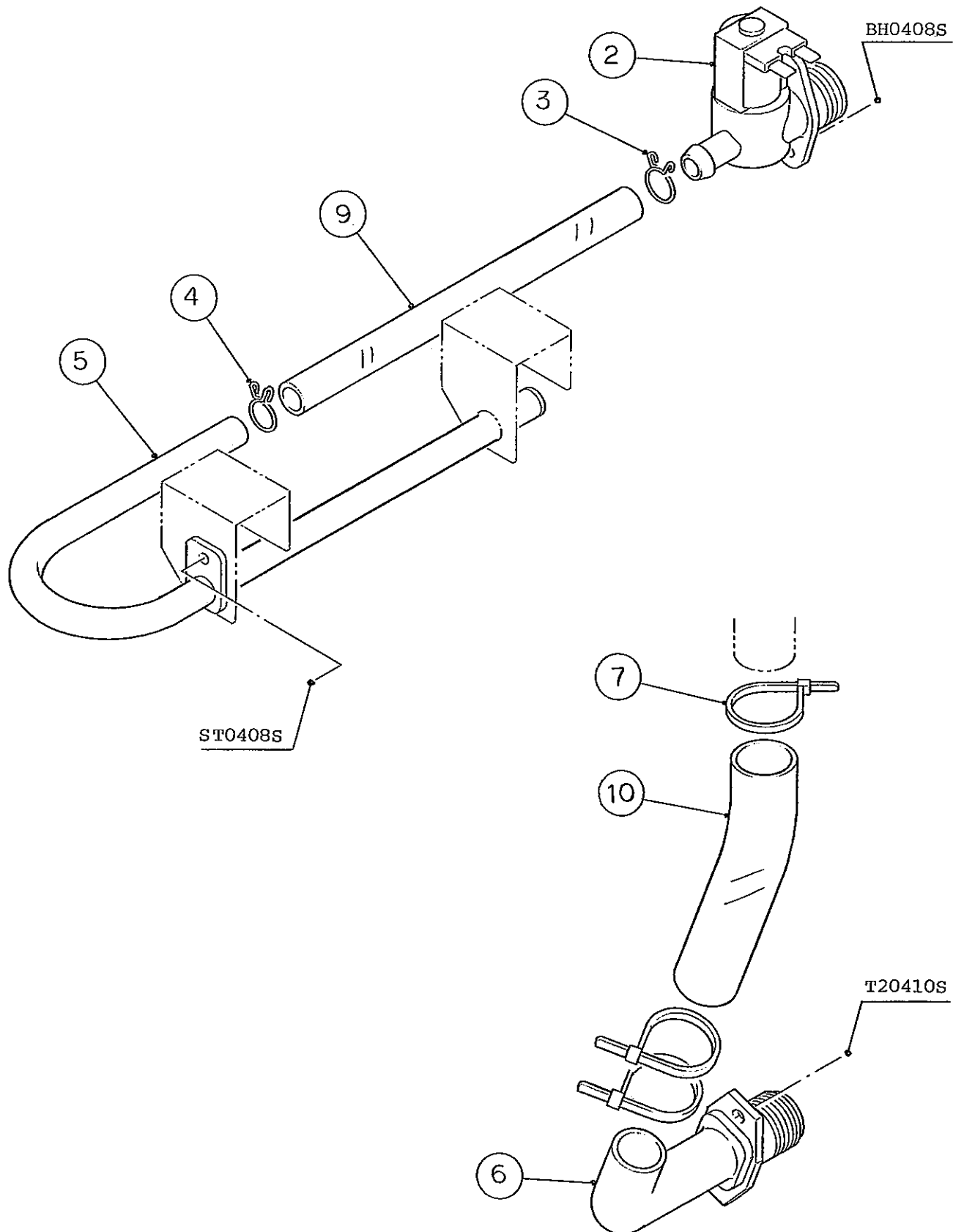

IM-45LE
IM-45LE-25

G. LABEL LOCATION

(D-1) (D-2) (E-0) (E-1) and later
(B-0) (C-0) (C-1) (D-0)
(J-0) (K-0) (K-1) (A-0)
(F-2) (G-1) (H-0) (H-1)

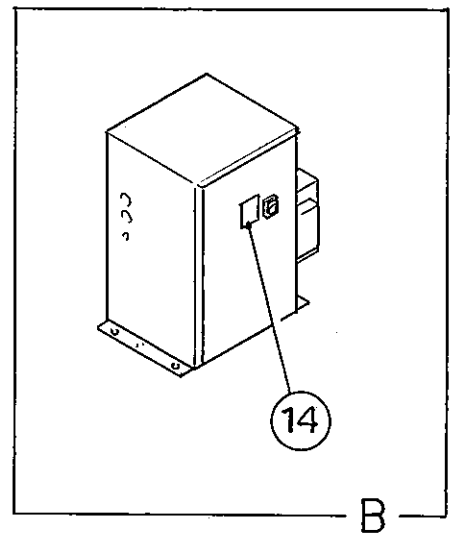
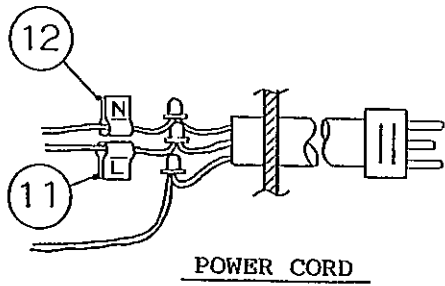
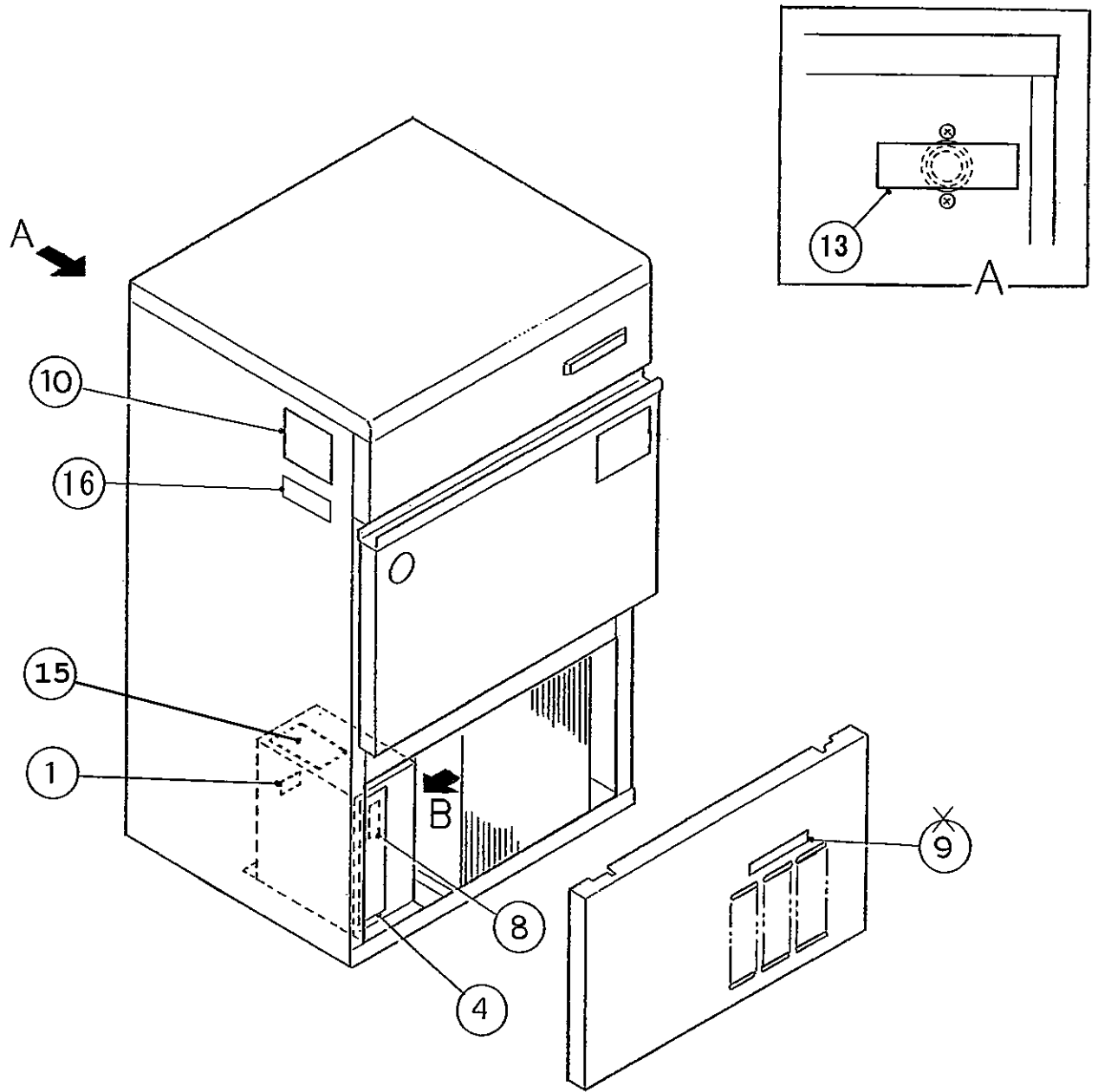

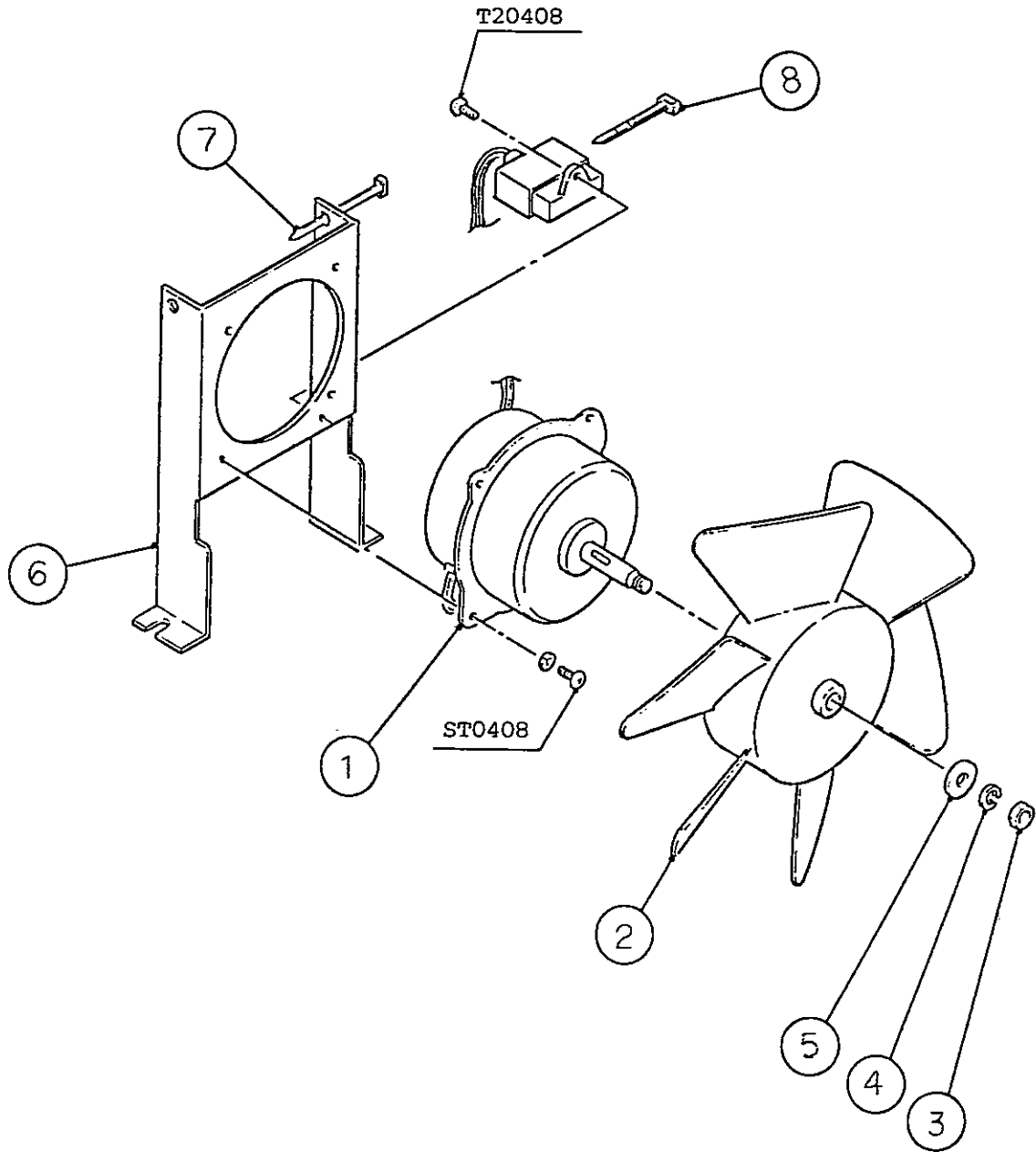

IM-45LE
IM-45LE-25

H. FAN MOTOR ASSY

(D-1) (D-2) (E-0) (E-1) and later
(B-0) (C-0) (C-1) (D-0)
(J-0) (K-0) (K-1) (A-0)
(F-2) (G-1) (H-0) (H-1)

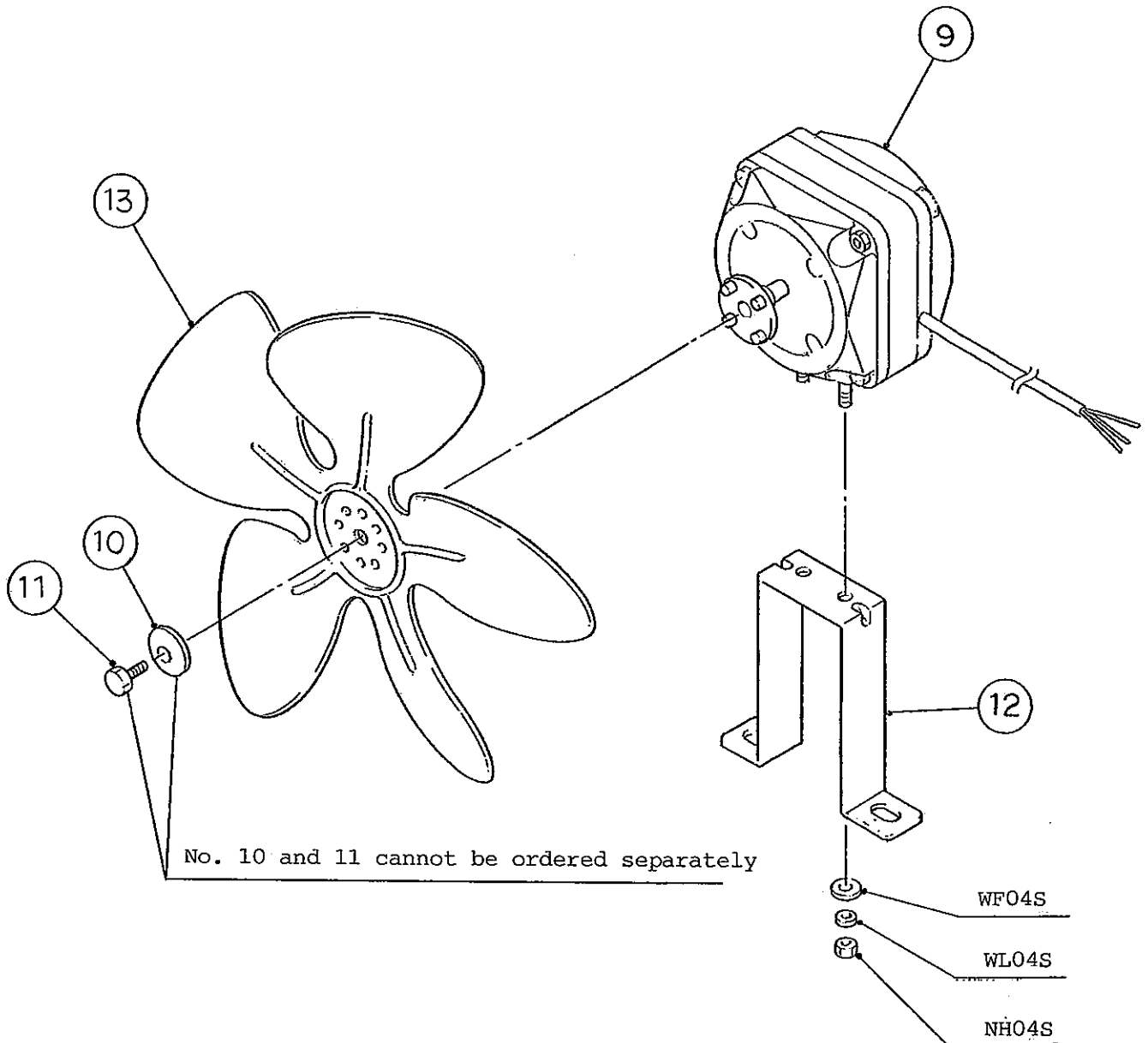

IM-45LE
IM-45LE-25

J. BIN CONTROL SWITCH ASSY

(E-1) and Later
(D-0) (D-1) (D-2) (E-0)
(A-0) (B-0) (C-0) (C-1)
(H-1) (J-0) (K-0) (K-1)
(F-1) (F-2) (G-1) (H-0)

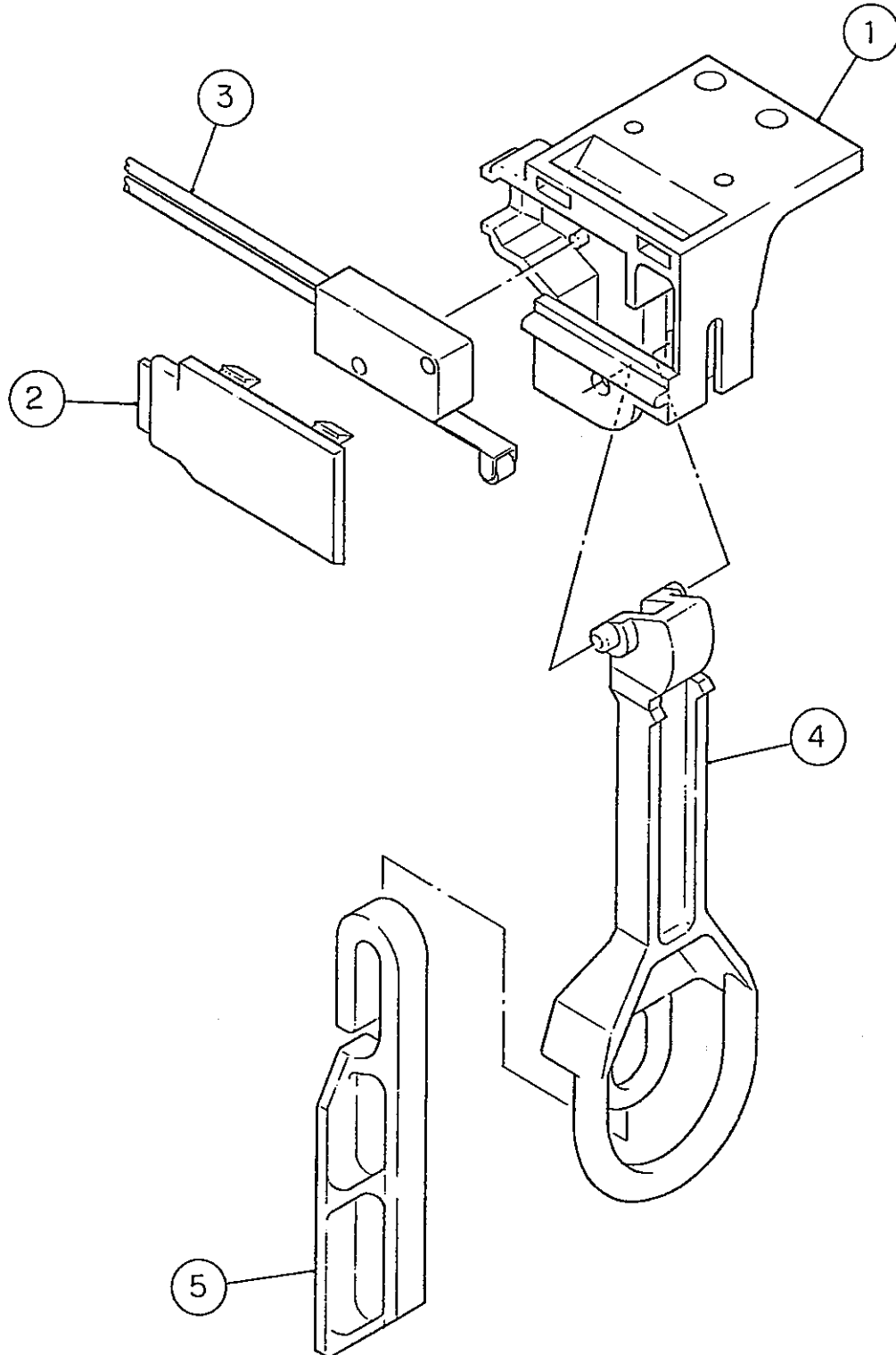

IM-45LE
IM-45LE-25

K. WATER PAN ASSY

(E-1) and later
(D-0) (D-1) (D-2) (E-0)
(A-0) (B-0) (C-0) (C-1)
(H-1) (J-0) (K-0) (K-1)
(F-1) (F-2) (G-1) (H-0)

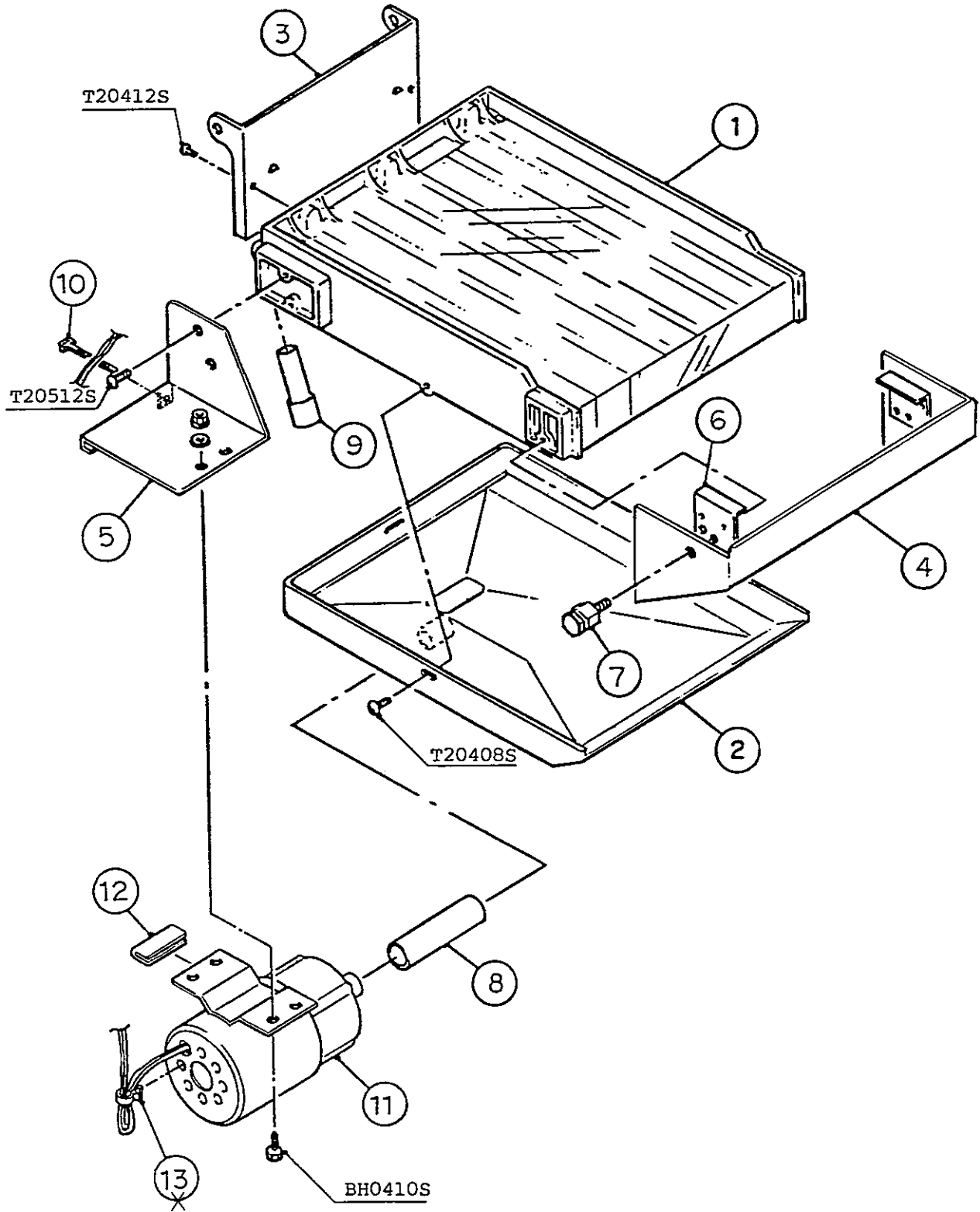

(S-0424)

IM-45LE
IM-45LE-25

L. FITTING (K) ASSY

(F-2) (F-1)

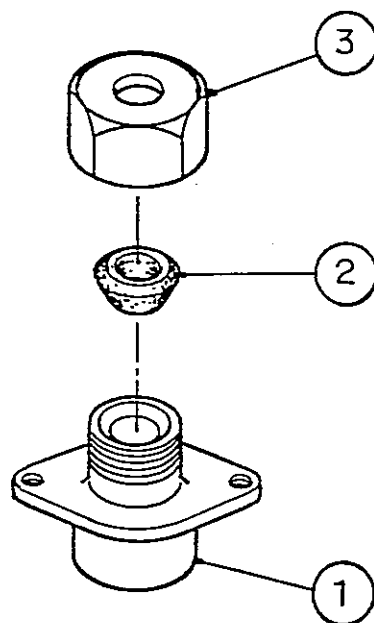

IM-45LE
IM-45LE-25

M. ACCESSORIES

(E-1) and later
(D-0) (D-1) (D-2) (E-0)
(A-0) (B-0) (C-0) (C-1)
(H-1) (J-0) (K-0) (K-1)
(F-1) (F-2) (G-1) (H-0)

