



First Choice Group

SPARE PARTS DIAGRAM FOR

winterhalter

Dish/Glass Washer

GR62/2

GR62/3

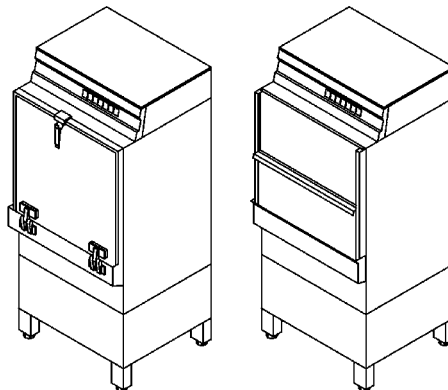

First Choice Group
Blakeney Way, Kingswood Lakeside
Cannock, Staffs, WS11 8LD
TEL: 01543 577778 FAX: 01543504141
Email: enquires@firstchoice-cs.co.uk
Web: www.firstchoice-cs.co.uk

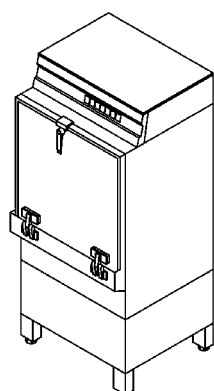

GR 62/2

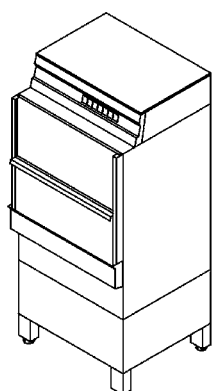

GR 62/3

Spare parts list GR 62/2 / GR 62/3

Edited: 12/95
Revised: 09/00

Part.-no.: 89001813

Summary

Water inlet	Page 1 and 2
Water drain and tank heating	Page 3 and 4
Mediamat	Page 5 and 6
Wash system I - mach.-no.: ⇒ 231 260	Page 7 and 8
Wash system I - mach.-no.: 231 261 ⇒	Page 9 and 10
Wash system II	Page 11 and 12
Wash system III	Page 13 and 14
Reversing	Page 15 and 16
Rinsing I	Page 17 and 18
Rinsing II - AquaMatik	Page 19 and 20
Rinsing III - AquaMatik	Page 21 and 22
Rinsing IV	Page 23 and 24
Dosing	Page 25 and 26
Door GR 62/2	Page 27 and 28
Door GR 62/3	Page 29 and 30
Door limit switch	Page 31 and 32
Panelling	Page 33 and 34
Electrical parts I	Page 35 and 36
Electrical parts II	Page 37 and 38
Electrical parts II - with soft starter ⇒ 342 720	Page 39 and 40
Electrical parts III	Page 41 and 42
Cold water pre-rinsing (Option)	Page 43 and 44
Drain pump (Option)	Page 45 and 46
Cake ring - cleaning drum (Option)	Page 47 and 48

Please note the following points with regard to this list:

See separate list for racks and accessories.

Enter the required quantity in the column marked "Pc." if more than 1 part is installed and if this part is not a standard part.

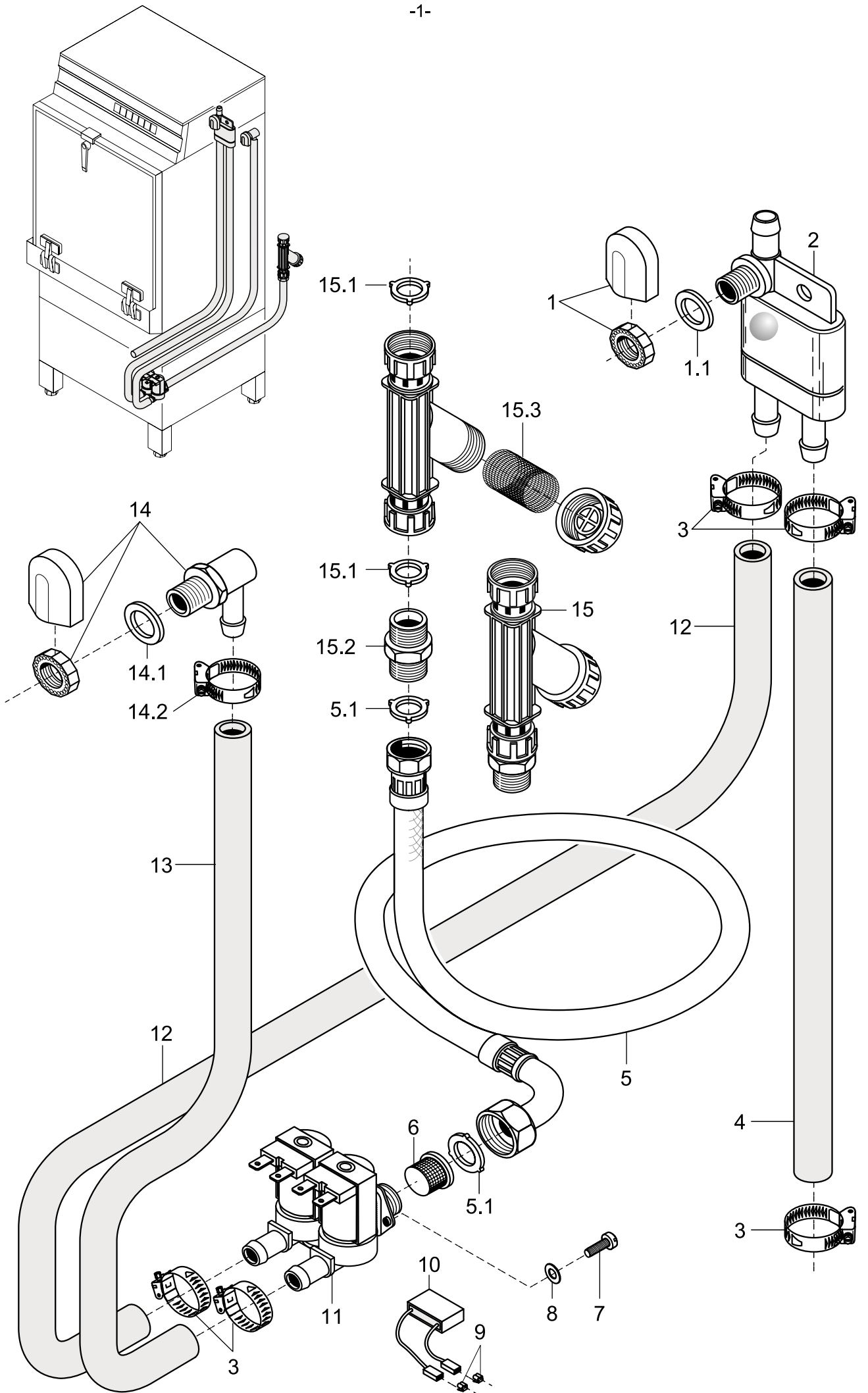

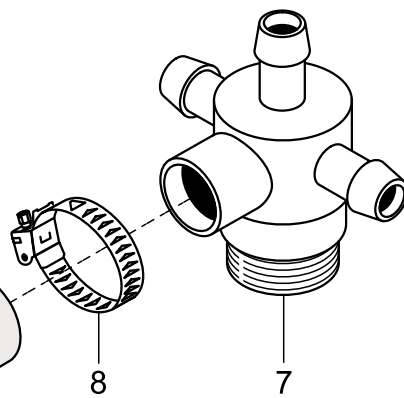
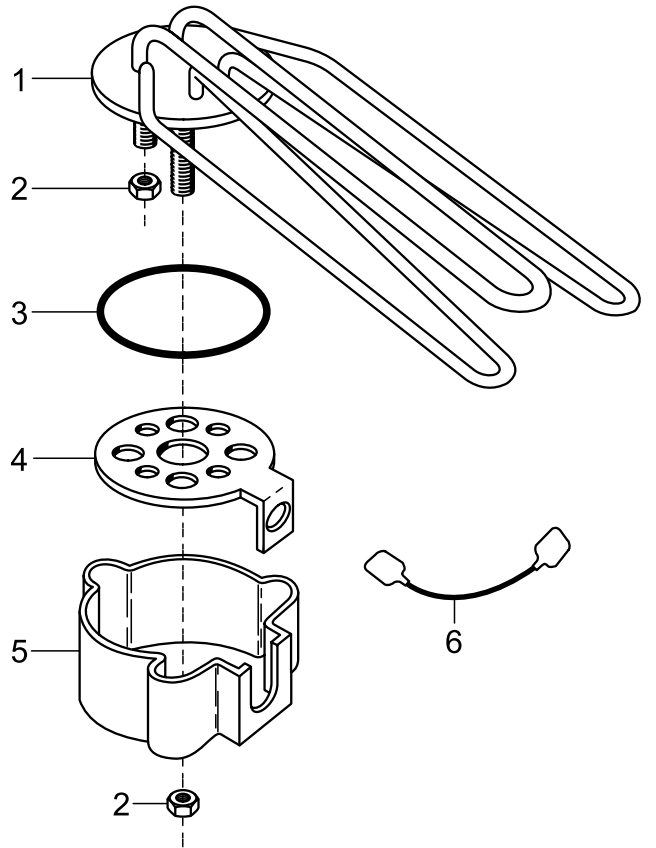
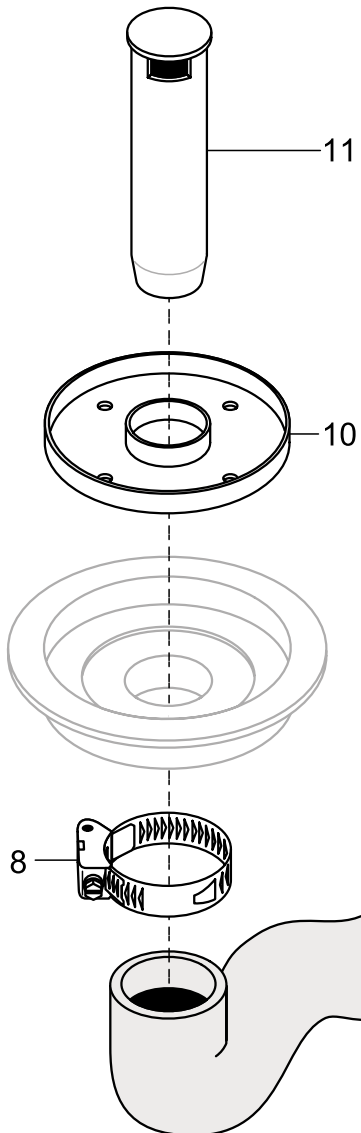
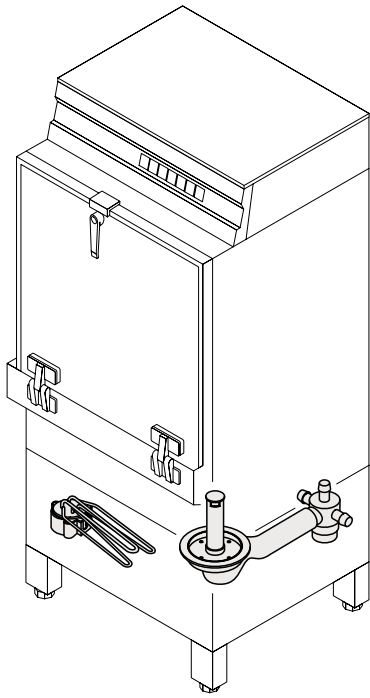

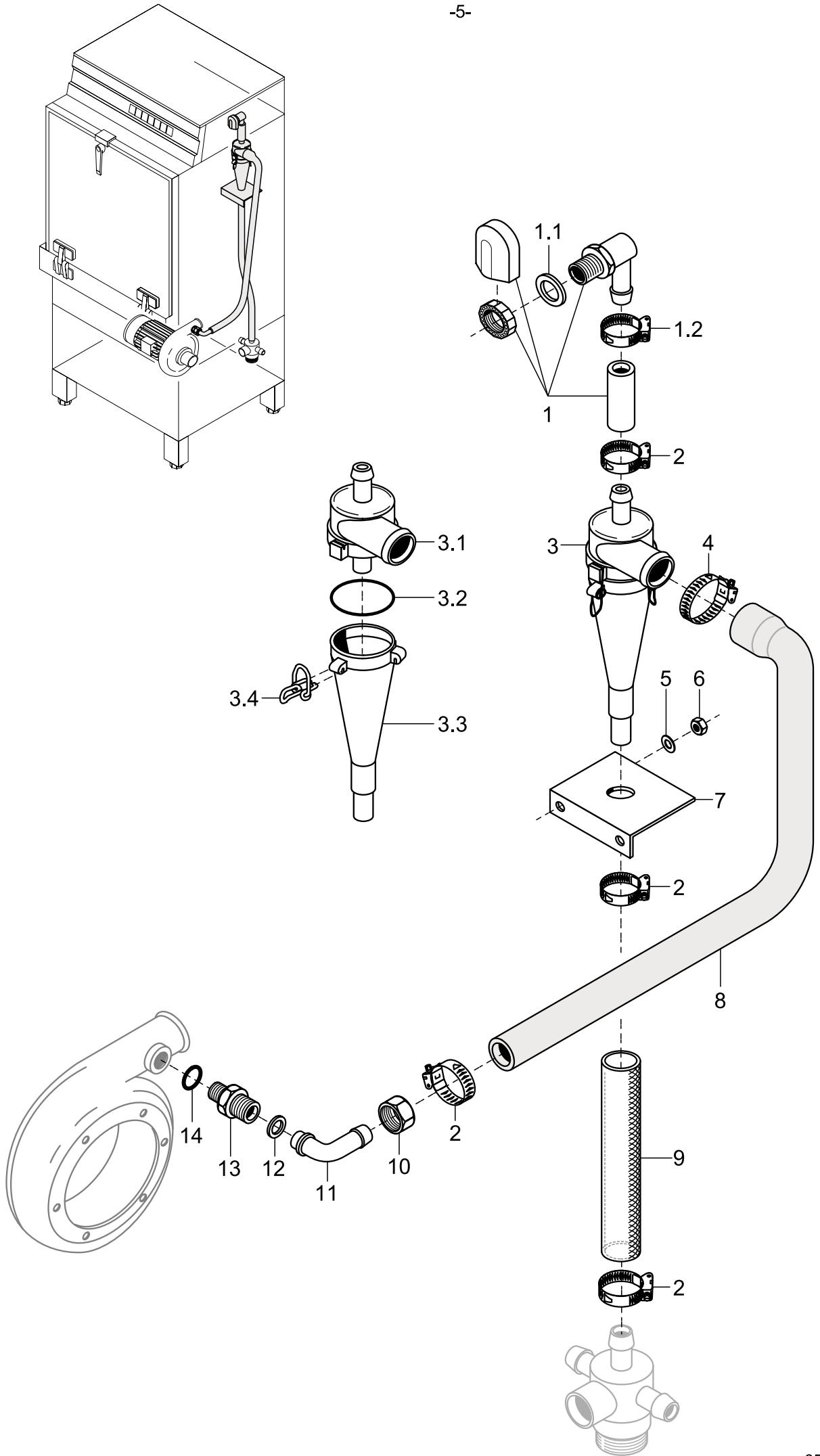

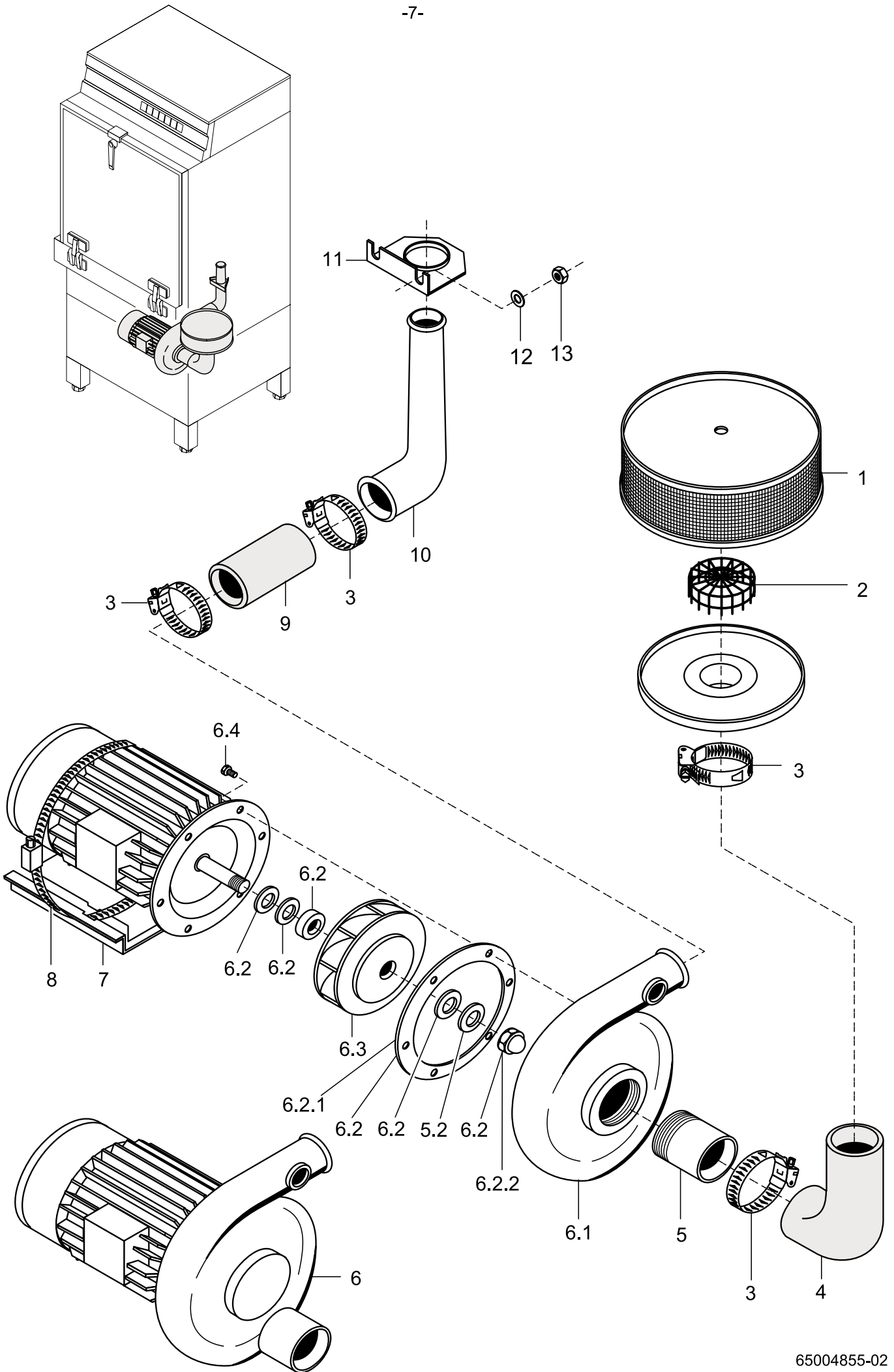

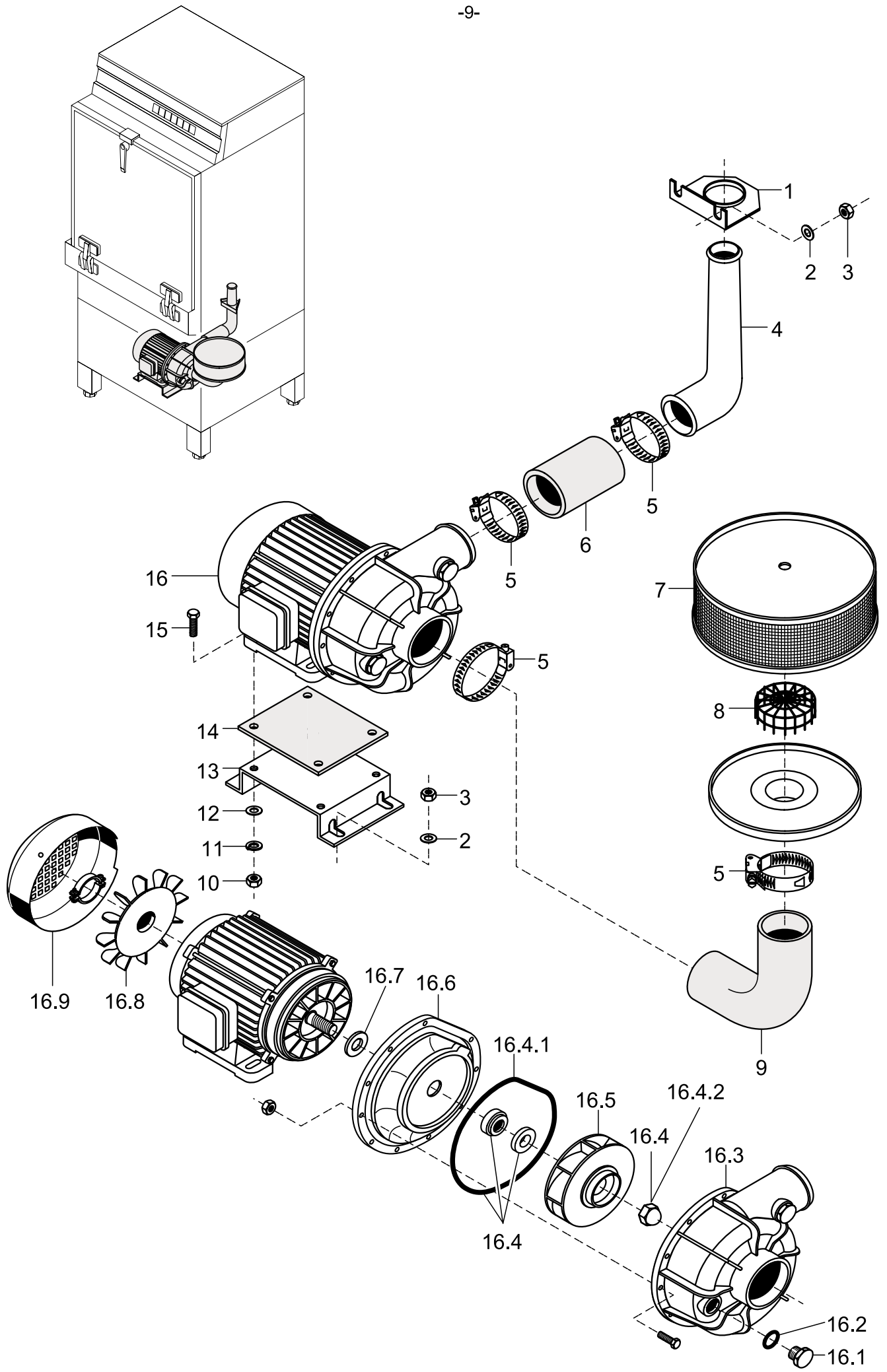

GR 62/2

Wash system I - mach.-no.: 231 261 ⇨

Item	Designation	Part no.	Pc.	Notes
1	Support	65000023		
2	Washer; \varnothing 6.4 x \varnothing 12.5 x 1.6	22 01 302		
3	Hex nut; M 6 self-locking	21 05 304		
4	Reducing elbow	55 06 051		
5	Hose clip; \varnothing 70 - \varnothing 90 x 12	28 02 120		
6	Pump hose, \varnothing 60 x 8 x 170	55 05 032		made of: 40 02 007
7	Pump strainer	55 13 004		
8	Intake strainer	61002500		
9	Shaped hose; nom. dia. 62 x 9.0; 80 x 180	40 03 028		
10	Hex nut; M 8	21 01 305	2	
11	Lock washer; B 8	23 03 301	2	
12	Washer; \varnothing 8.4 x \varnothing 17 x 1.6	22 01 303	2	
13	Pump bracket	61002191		
14	Shim	65002991		
15	Hex-head screw; M 8 x 30	20 01 304	2	
16	Pump; 2.6 kW; 230-240/400-420 V / 3 / 50 Hz	31 02 340		incl. items 16.1 - 16.9
	Pump; 2.6 kW; 230/400 V / 3 / 60 Hz	31 02 347		
	Pump; 2.6 kW; 200/346 V / 3 / 50 Hz	31 02 348		
	Pump; 2.6 kW; 200/346 V / 3 / 60 Hz	31 02 349		
16.1	Filler plug; G 1/2" x 20.5	35 01 108		
16.2	O-ring; 20 x 3.5	27 07 040		
16.3	Pump housing	31 02 243		
16.4	Sealing kit	80002671		incl. item 16.4.1, 16.4.2
16.4.1	Seal	31 02 307		
16.4.1	Nut; M14 LH	31 02 404		
16.5	Pump impeller; \varnothing 136mm	31 02 306		for 50 Hz - pump
	Pump impeller; \varnothing 115.5mm	31 02 310		for 60 Hz - pump
16.6	Pump cover	31 02 396		
16.7	Oil slinger	31 02 304		
16.8	Fan impeller	31 02 308		
16.9	Fan impeller cover	31 02 309		

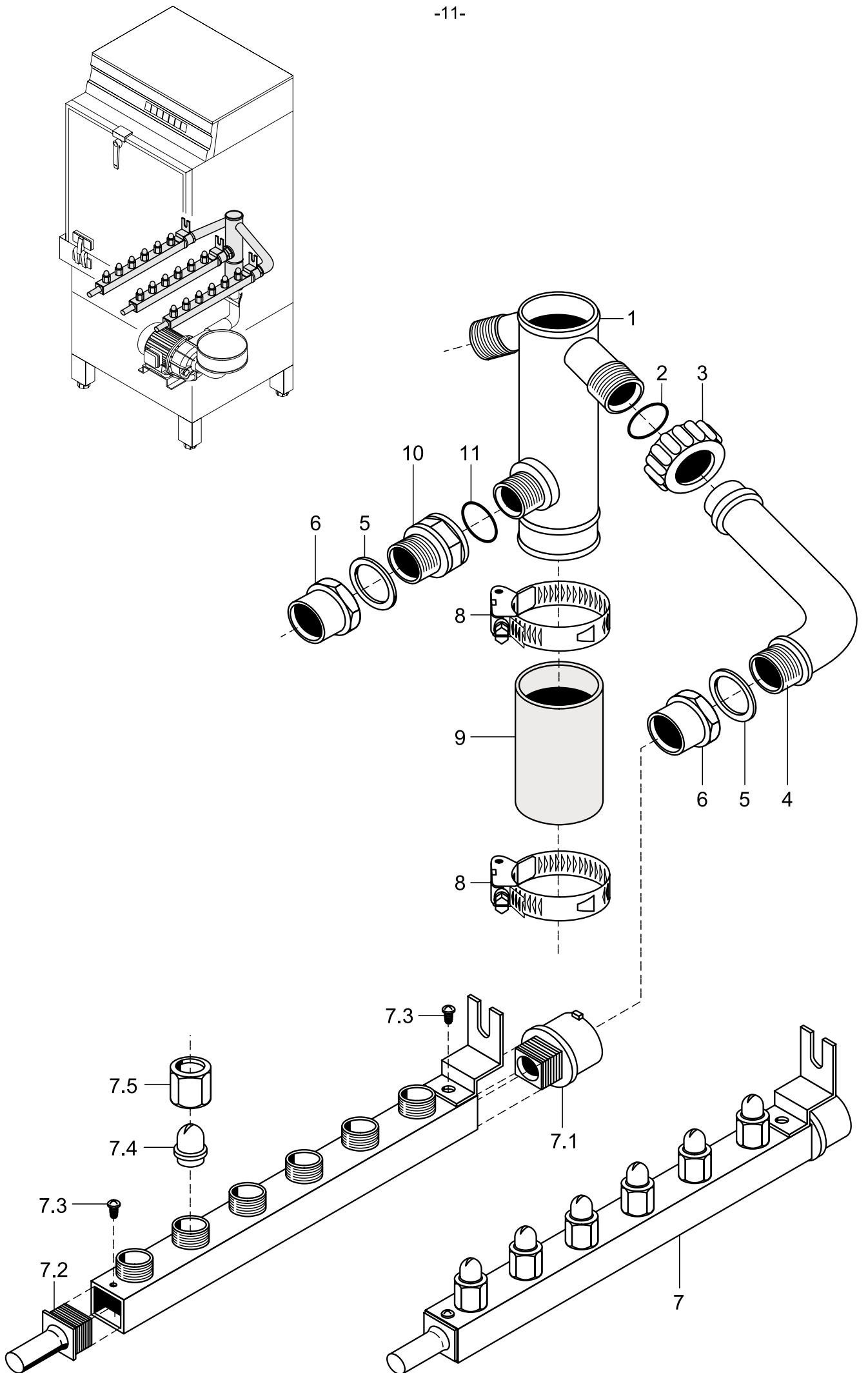

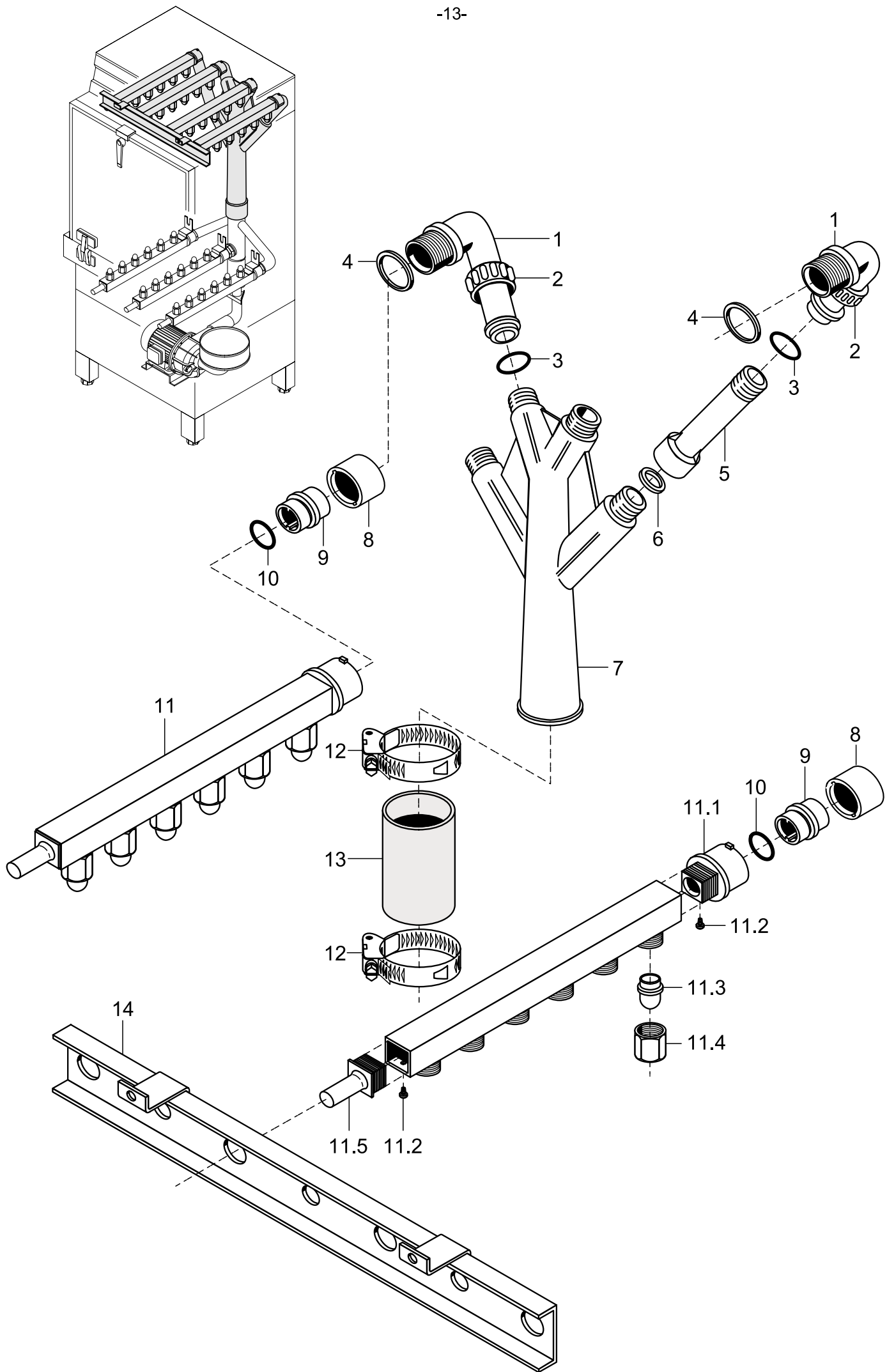

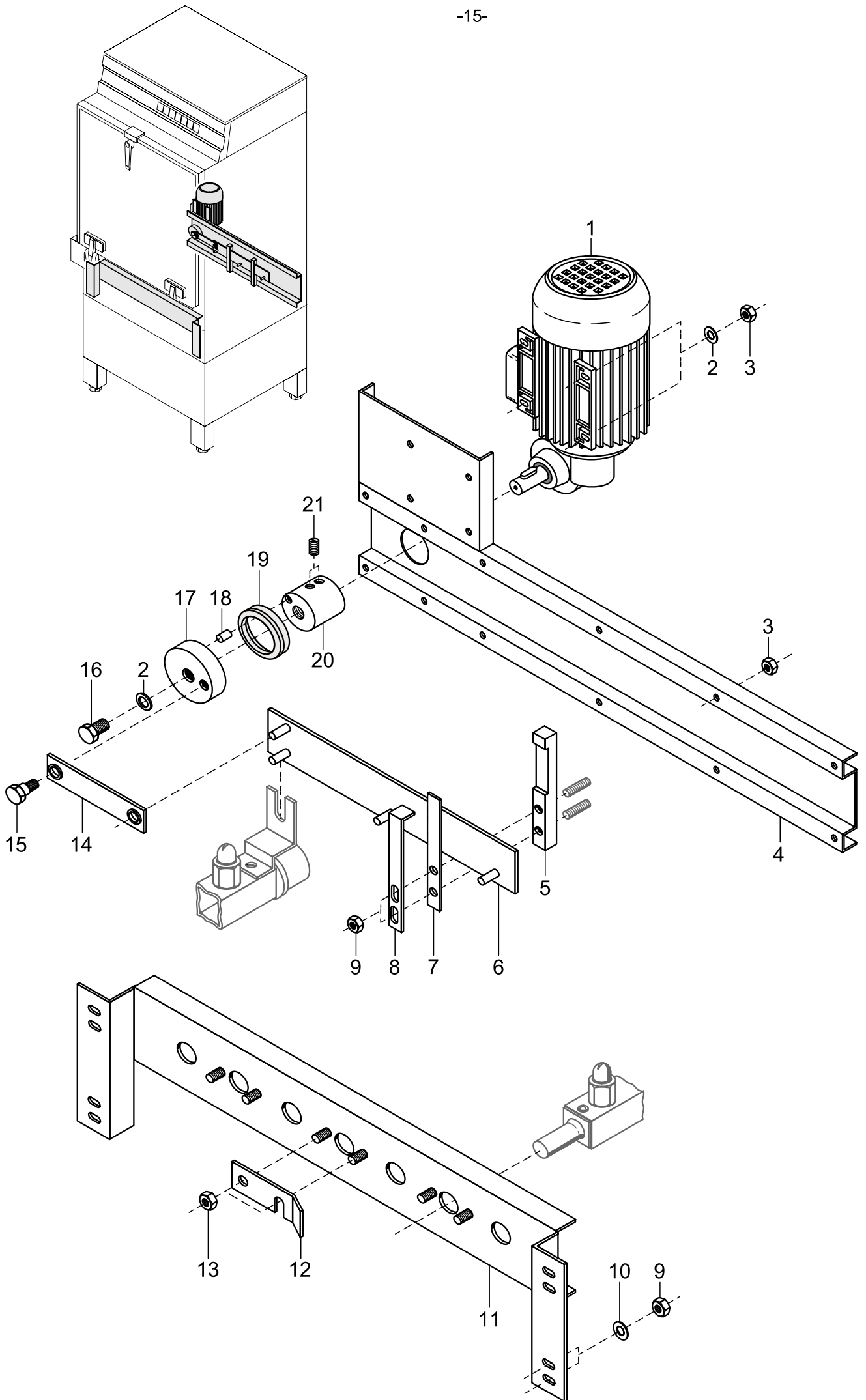

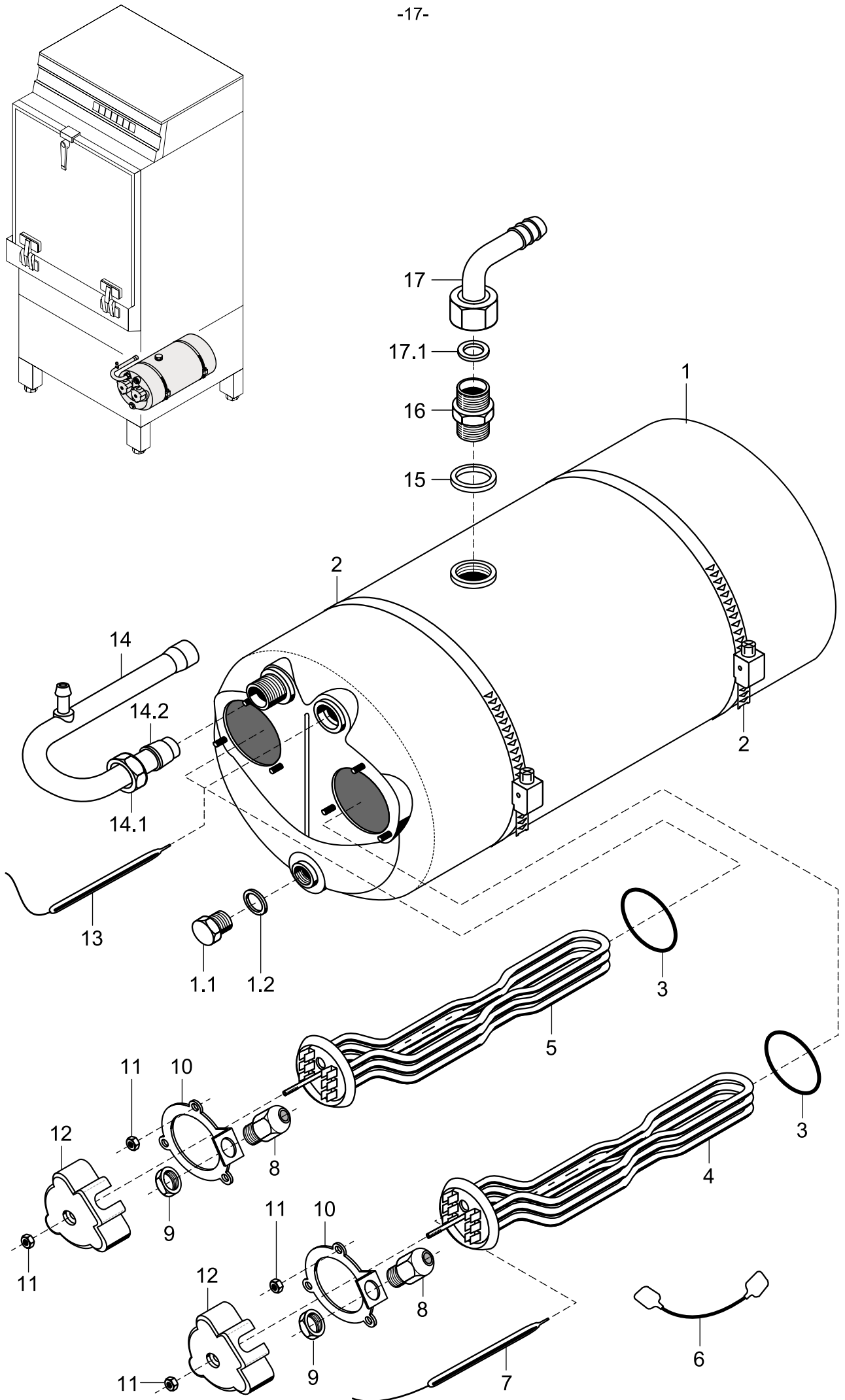

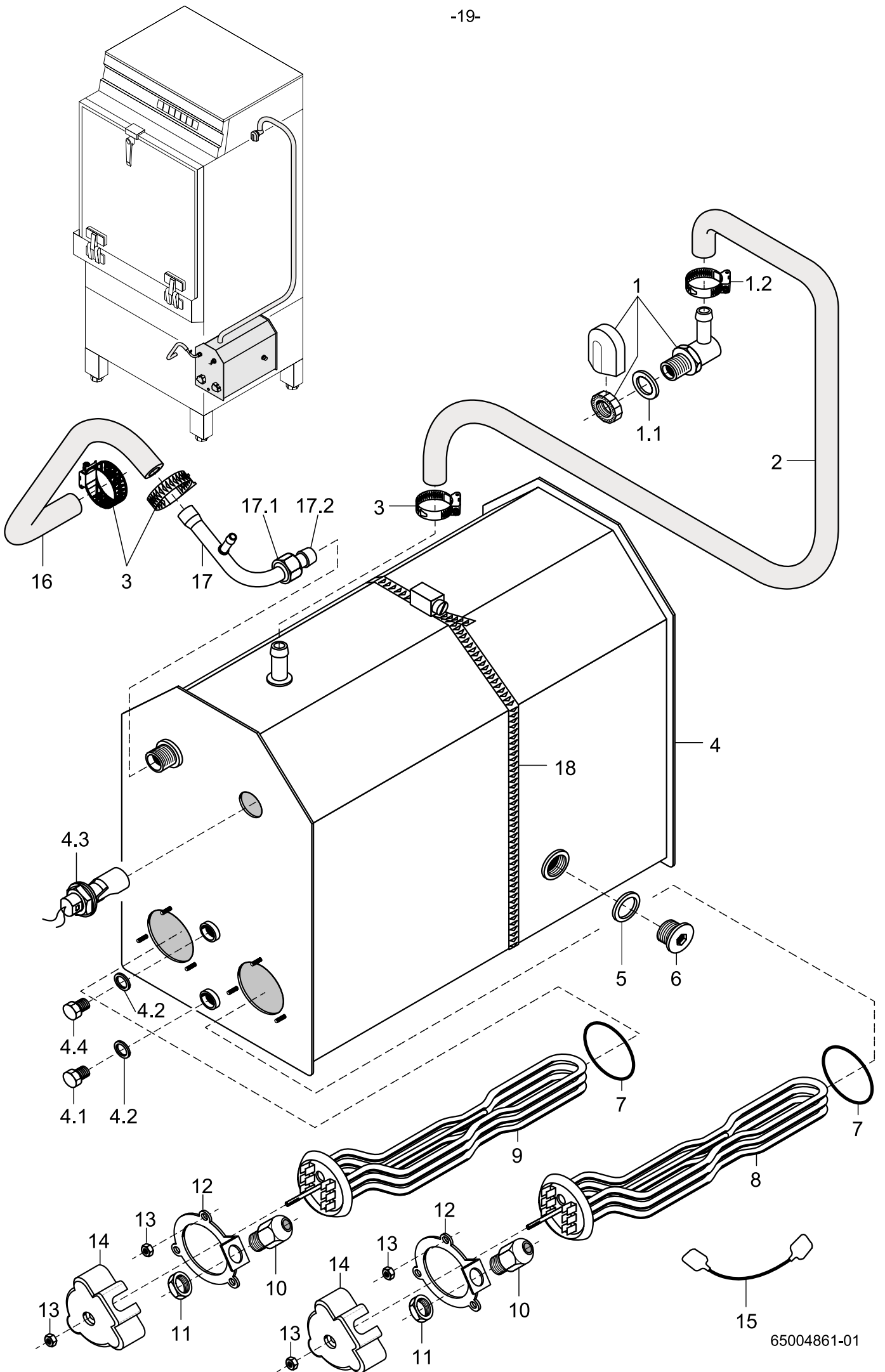

GR 62/2

Rinsing II - AquaMatik

Item	Designation	Part no.	Pc.	Notes
1	Water inlet set	55 31 007		incl. items 1.1, 1.2
1.1	Seal; \varnothing 20.5 x \varnothing 28.5 x 2.0	27 01 002		
1.2	Hose clip; \varnothing 14 - 24 x 9	28 02 108		
2	Hose bend; nom. dia. 12.5 x 4.0	40 03 056		
3	Hose clip; \varnothing 14 - 24 x 9	28 02 108		
4	Boiler frame cpl., non-pressurised	80002128		incl. items 4.1 – 4.4
4.1	Hex-head screw; M 10 x 16	20 01 352		
4.2	Seal; \varnothing 10 x \varnothing 18 x 1.5	27 03 003	2	
4.3	Float switch set; 250V; 15VA	55 28 255		
4.4	Hex-head screw; M 9 x 1 x 14	70003890		
5	Seal; \varnothing 21 x \varnothing 28 x 2.0	27 09 011		
6	Locking screw; G 1/2"	30 08 303		
7	O-ring; 46 x 6.0	27 07 015		
8	Heating element cranked; 6.0kW; 230V/400V/3	31 03 017		
	Heating element cranked; 6.0kW; 240V/420V/3	31 03 043		
	Heating element cranked; 6.0kW; 200V/346V/3	31 03 046		
9	Heating element cranked; 9.0kW; 230V/400V/3	31 03 018		soft starter
	Heating element cranked; 9.0kW; 240V/420V/3	31 03 057		soft starter
10	Cable gland; PG 13.5	31 10 040		
11	Hex nut; PG 13.5	31 10 041		
12	Clamping plate cpl.	55 19 018		
13	Hex nut; M 5	21 01 203		
14	Cap	31 03 014		use only with star bridge 31 23 088
15	Star bridge; 2.5 mm ²	70004616	2	Do not use cap 31 03 014
	Star bridge with nozzle; 2.5 mm ²	31 23 088		not available
16	Shaped hose; nom. dia. 13 x 4	40 03 053		
17	Boiler supply pipe bend cpl.	55 09 055		incl. items 17.1, 17.2
17.1	Cap nut; G 1/2" x \varnothing 12.2; width across flats 24	29 07 201		
17.2	Cutting ring; \varnothing 15 x 10; nom. dia. 12	29 07 300		
18	Hose clip, \varnothing 167 - \varnothing 187 x 12	28 02 124		

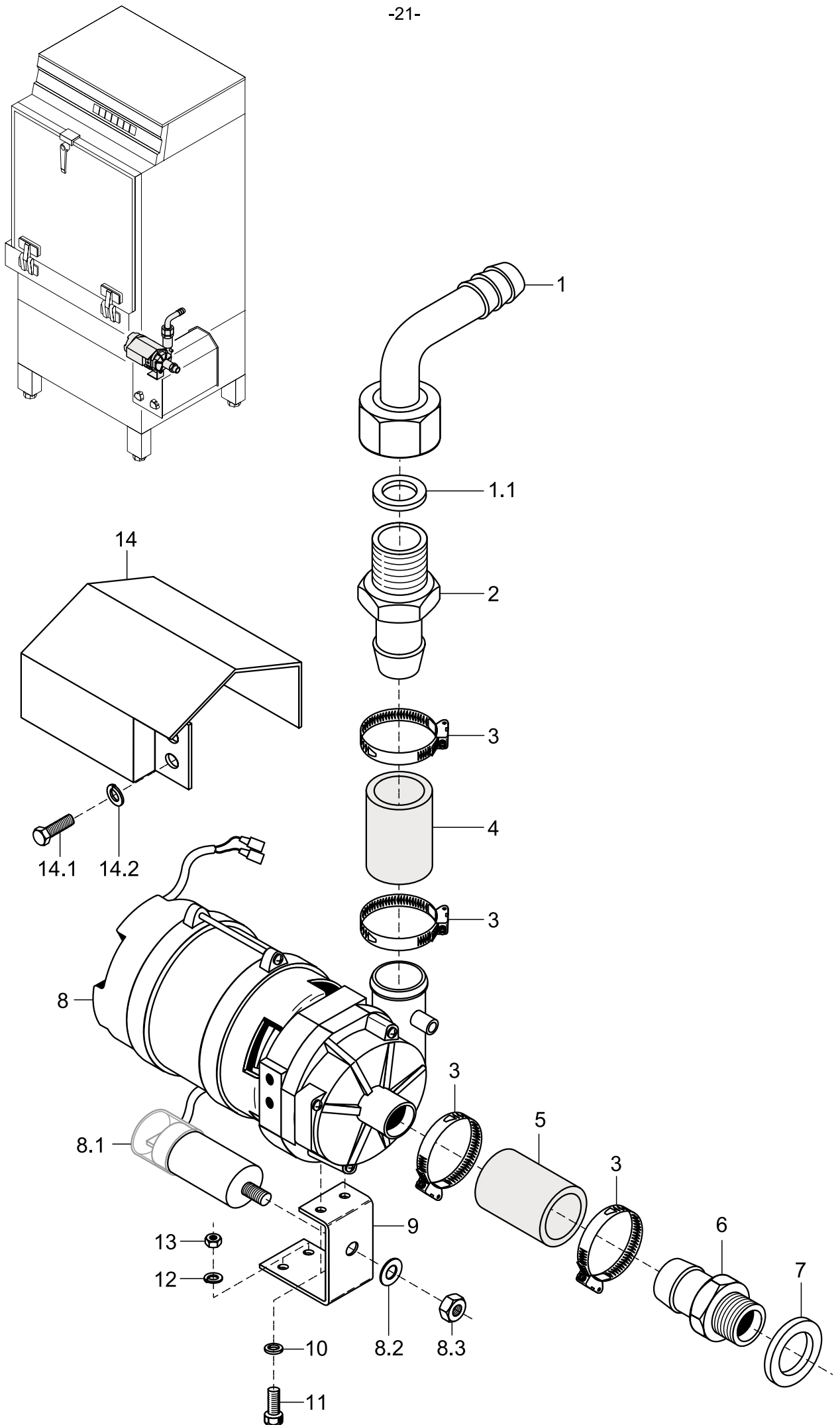

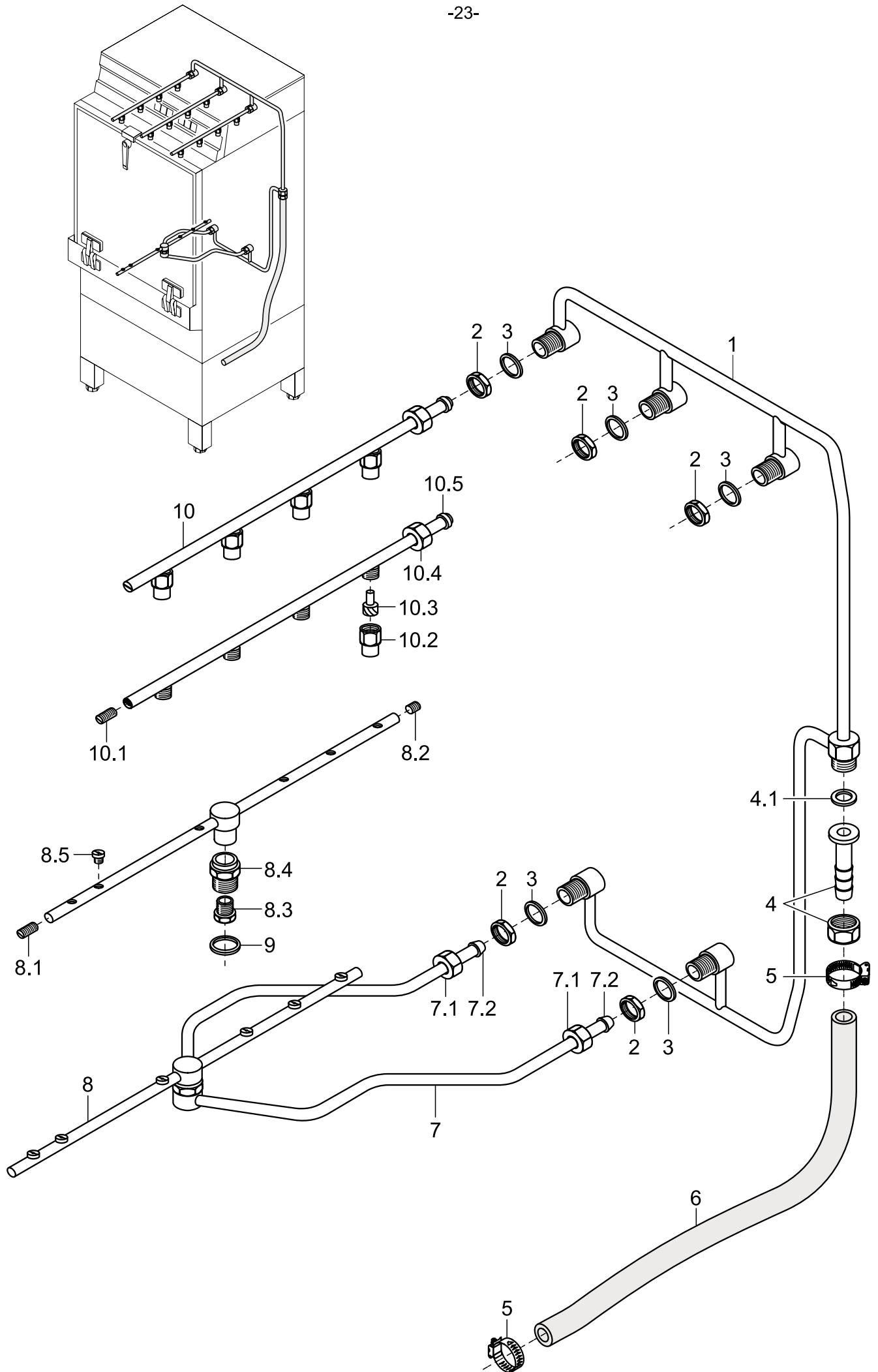

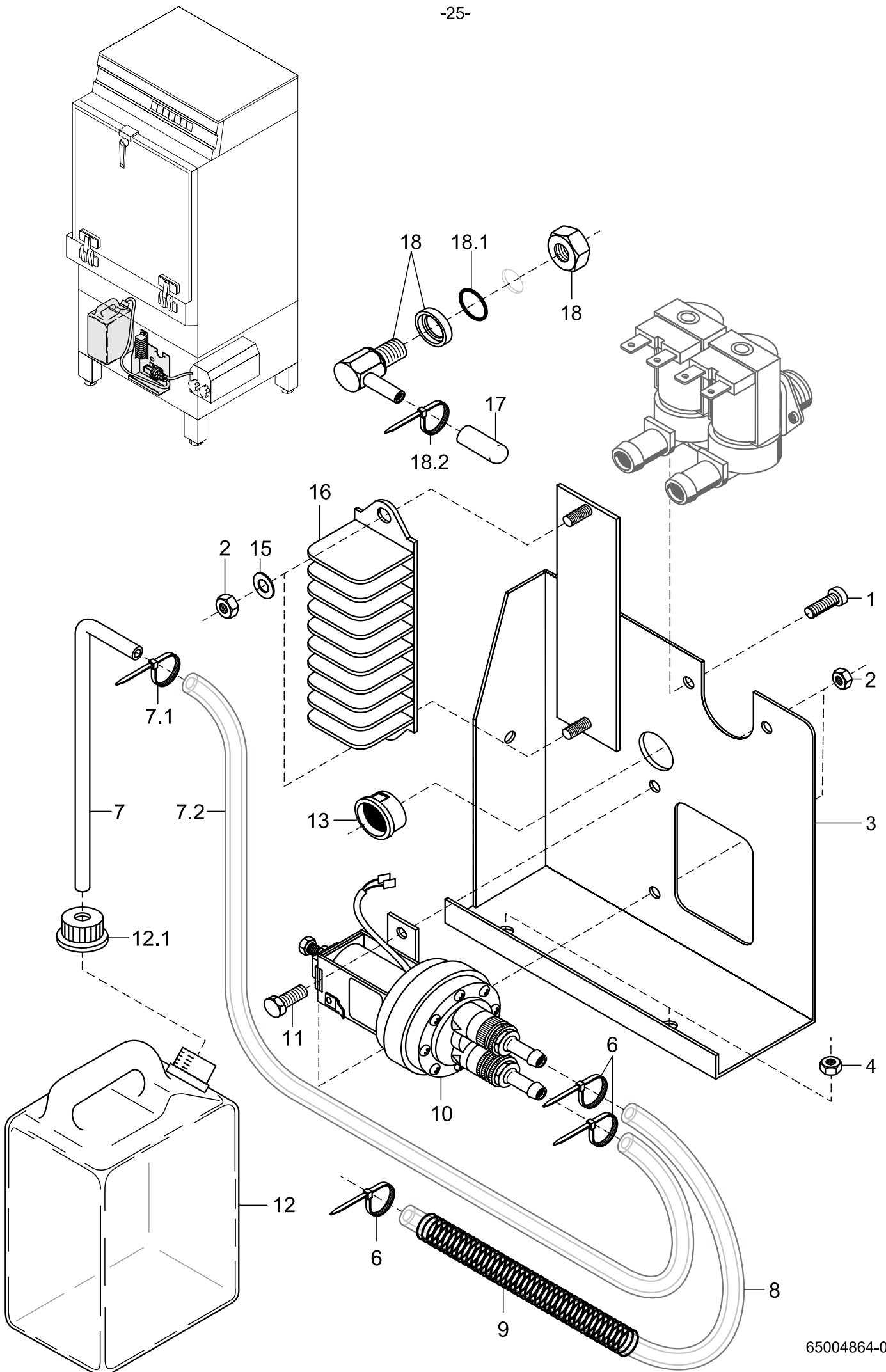

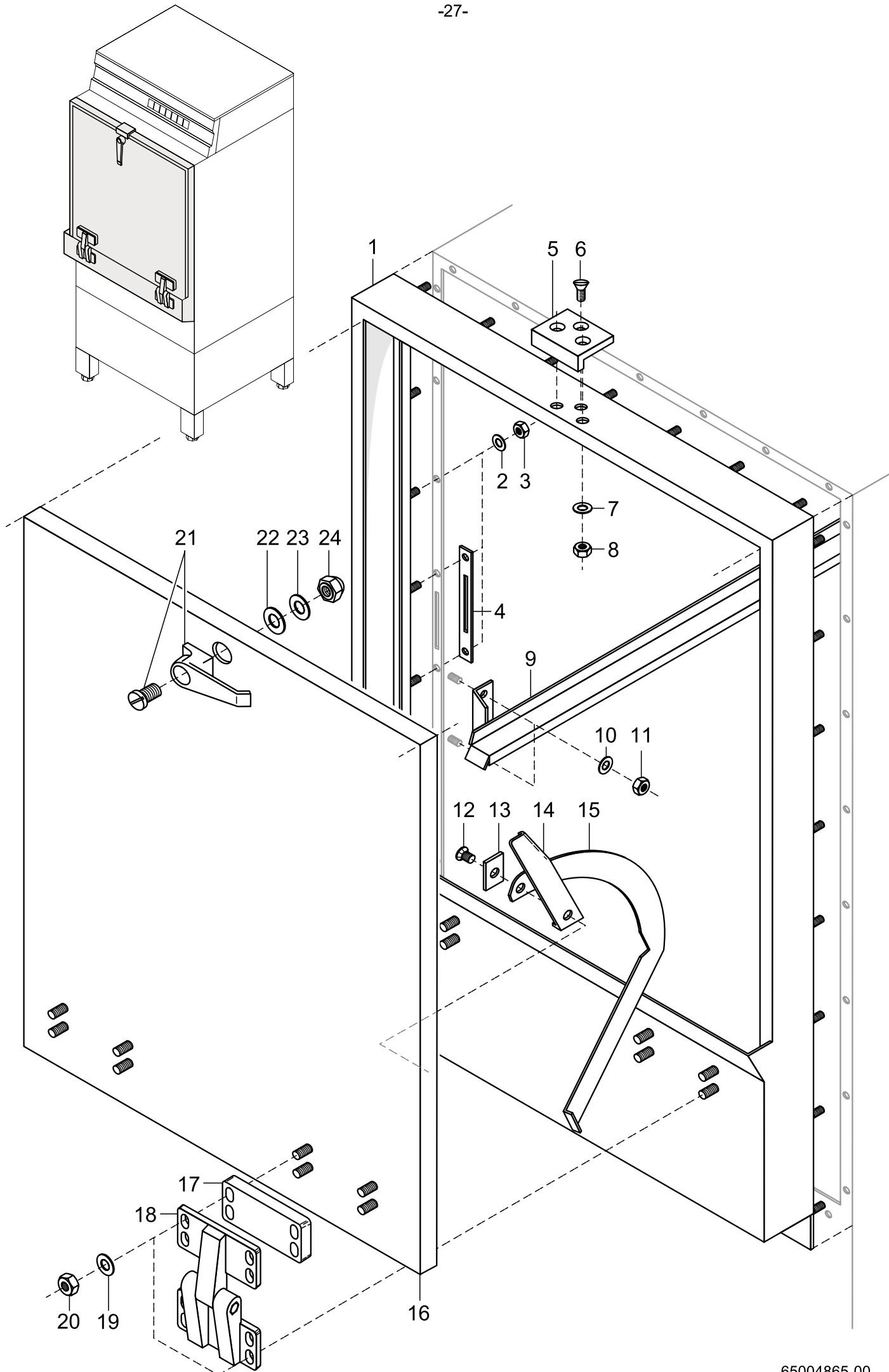

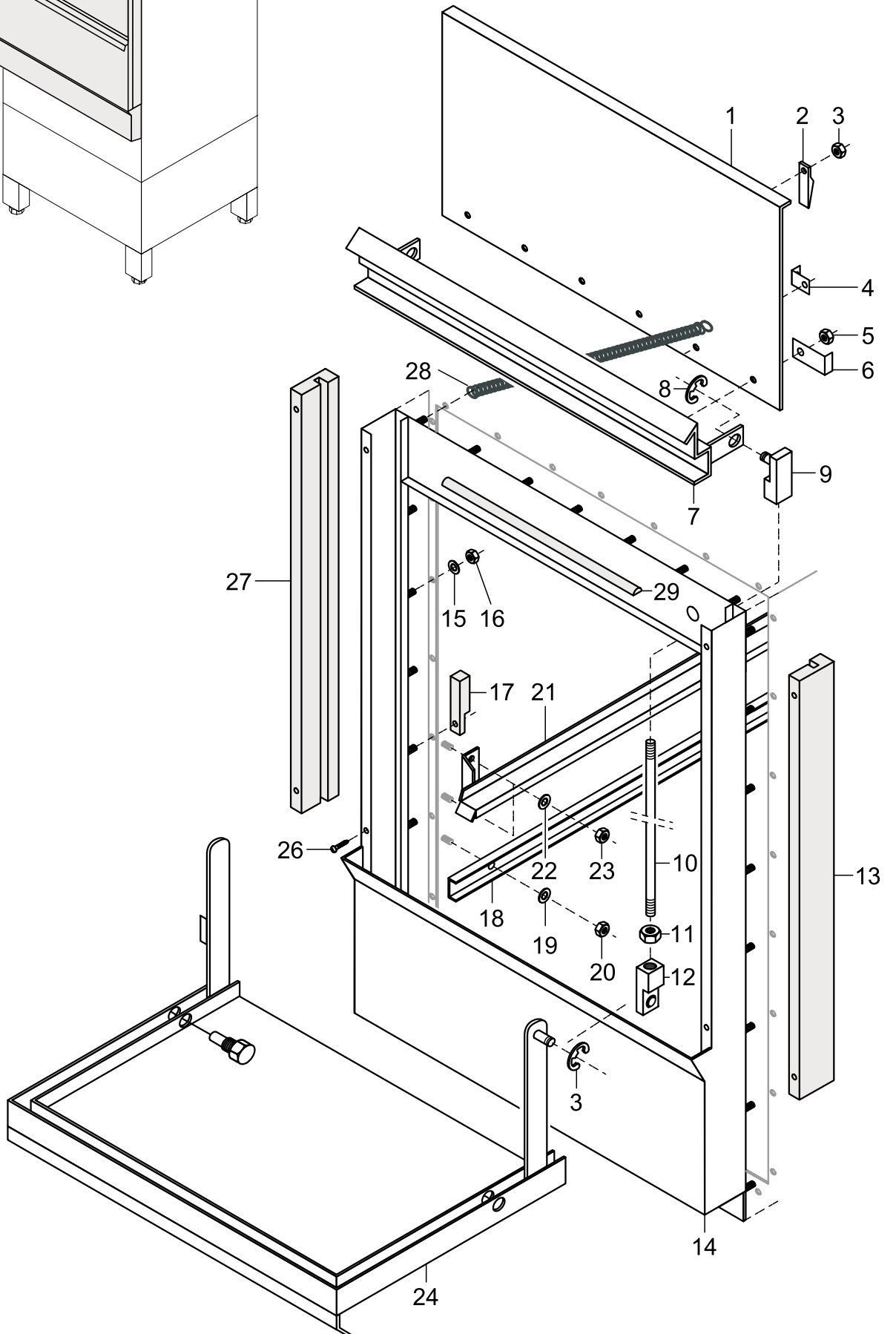
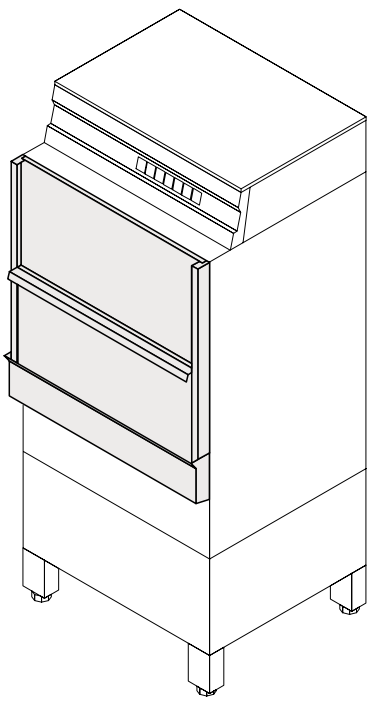

GR 62/3

Door

Item	Designation	Part no.	Pc.	Notes
1	Lifting door	65001550		
2	Stop wedge	65001734		
3	Lock washer; \varnothing 6 x 0.7	23 10 304		
4	Angle	65003612	2	
5	Hex nut; M 5 self-locking	21 05 302	6	
6	Angle	65003504		right
	Angle	65003505		left
7	Suspended rail	65001736		
8	Lock washer; \varnothing 6 x 0.7	23 10 304	4	
9	Adjusting knob; M 8 LH	65001617	2	
10	Door push rod, \varnothing 8 x 246	65001615	2	
11	Hex nut; M 8	21 01 305		
12	Adjusting knob; M 8 RH	65001616	2	
13	Guide section; right	65001620		
14	Door frame	65001730		
15	Washer; \varnothing 6.4 x \varnothing 12.5 x 1.6	22 01 302	32	
16	Hex nut; M 6 self-locking	21 05 304	32	
17	Lever stop	65001623	2	
18	Reinforcing section, side panel	65001696	2	
19	Washer; \varnothing 6.4 x \varnothing 12.5 x 1.6	22 01 302	4	
20	Hex nut; M 6 self-locking	21 05 304	4	
21	Rack rail, left	65001611		
	Rack rail, right	65001610		
22	Washer; \varnothing 6.4 x \varnothing 12.5 x 1.6	22 01 302	8	
23	Hex nut; M 6 self-locking	21 05 304	8	
24	Folding door	65001554		
25	Bearing bolt, width A/F 17 x 20	65001618	2	
26	Oval head screw; M 5 x 10	20 12 301	4	
27	Guiding section, left	65001621		
28	Tension spring, L0=416, DA=9.6, DD=1.6	28 04 103		
29	Gasket; 10 x 4 x 1000	62001618		per metre

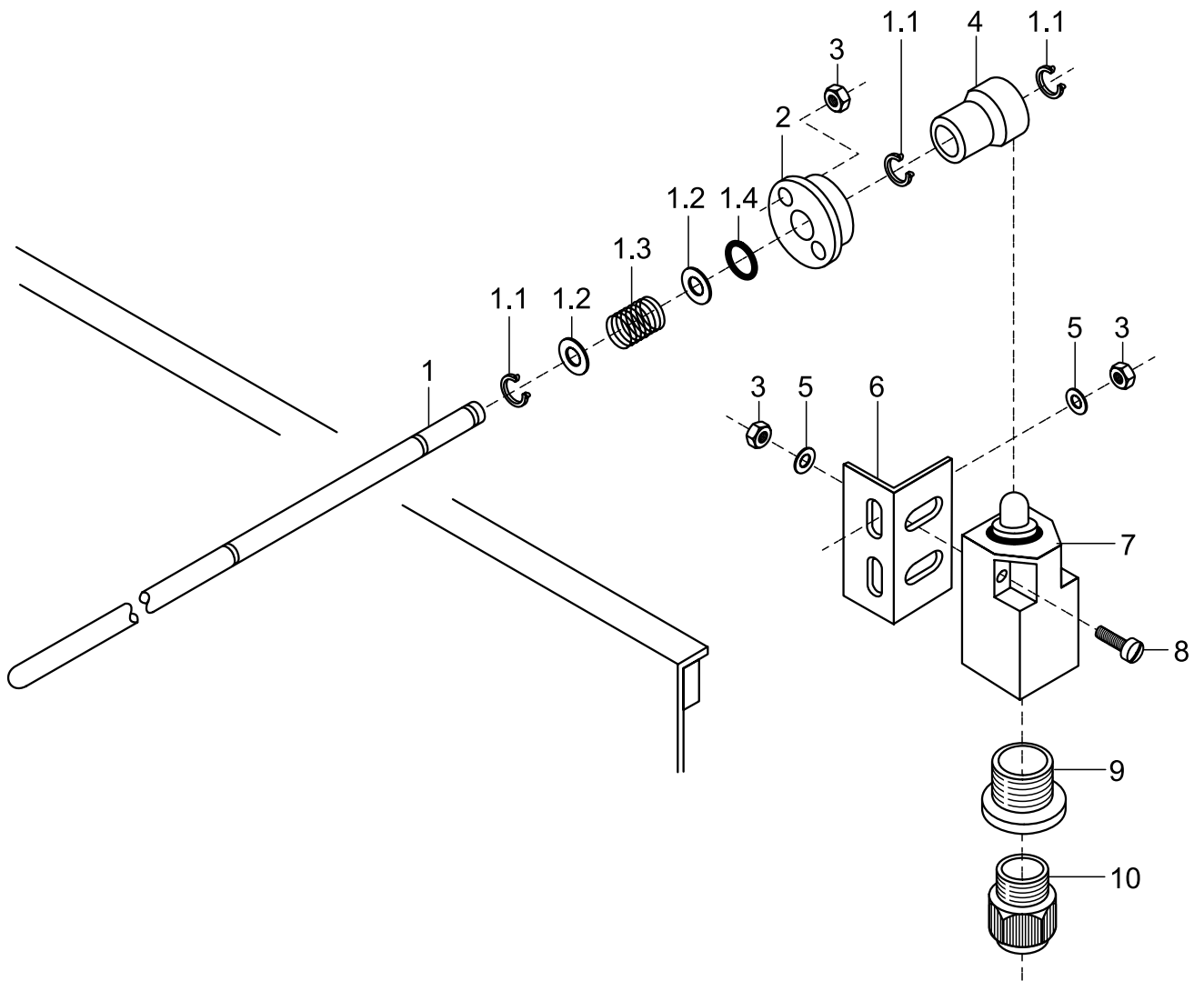
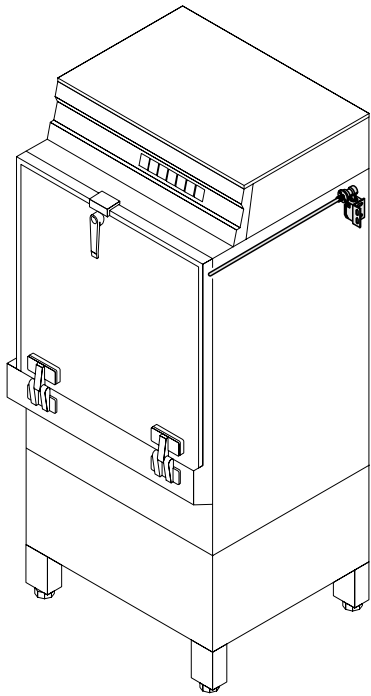

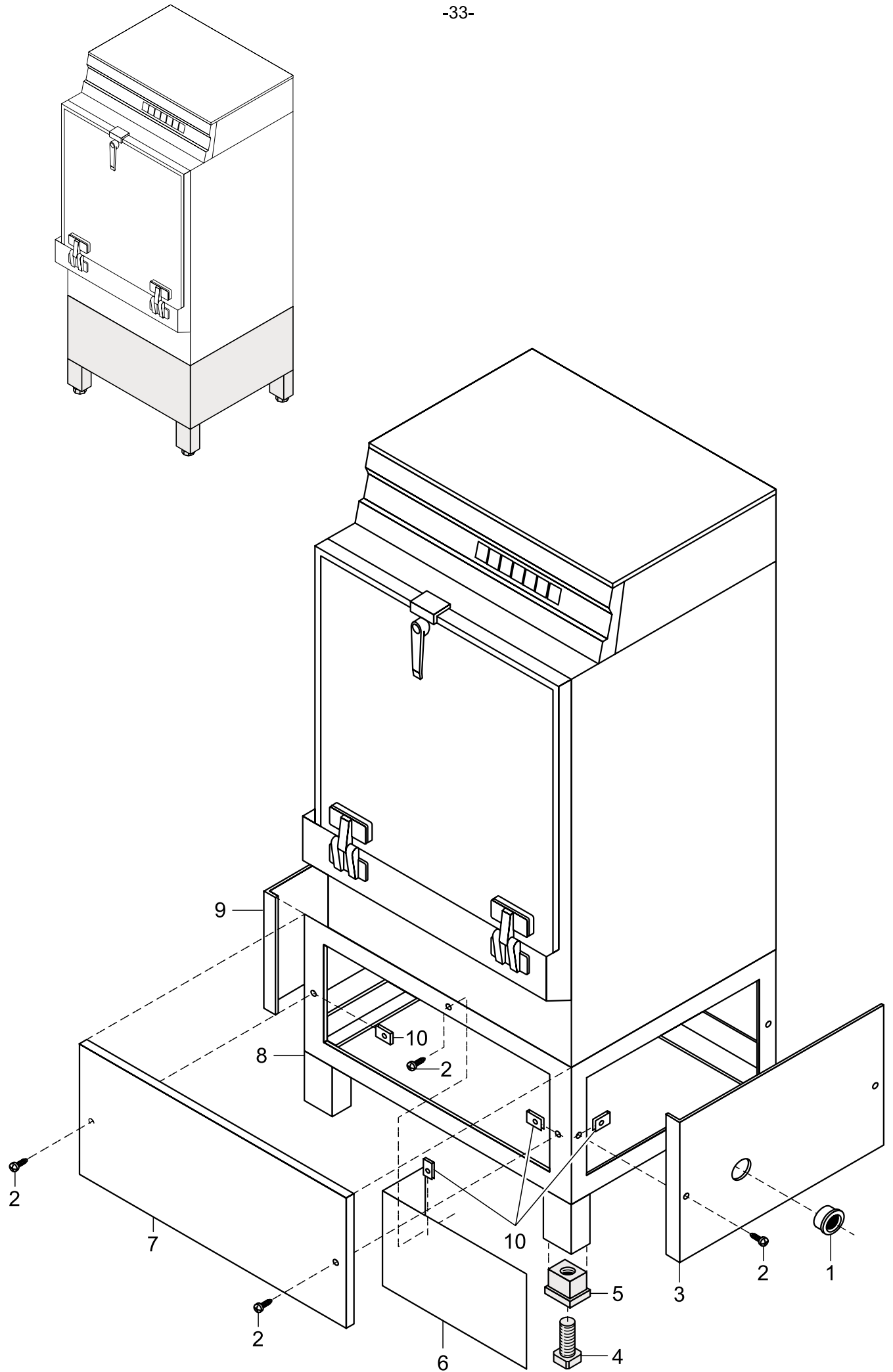

GR 62/2

Panelling

Item	Designation	Part no.	Pc.	Notes
1	Snap-on bushing; \varnothing 18 x \varnothing 13	31 10 069	2	mach.-no.: 342 721 \Rightarrow
2	Sheet-metal screw, B 3.9 x 16	20 20 300	6	
3	Panel; right	55 03 049		mach.-no.: \Rightarrow 342 720
	Panel; lateral	65003436		mach.-no.: 342 721 \Rightarrow
4	Foot cleat; G 3/4"; 32 x 32 x 100	35 01 064	4	
5	Threaded insert; G 3/4"; 42 x 62 x 50	35 01 063	4	
6	Cover; inside	65002918		mach.-no.: \Rightarrow 342 720
7	Panel; front	65003491		
8	Supporting frame cpl.	65002866		
9	Panel; lateral	65003436		
10	Sheet-metal nut; B 3.9	21 17 300	16	
n.p.	Rear panel	80001500		optional equipment
n.p.	Wall end piece	80001117		
n.p.	Foot extension; 50mm	80000542	4	
n.p.	Foot extension; 100mm	80000546	4	

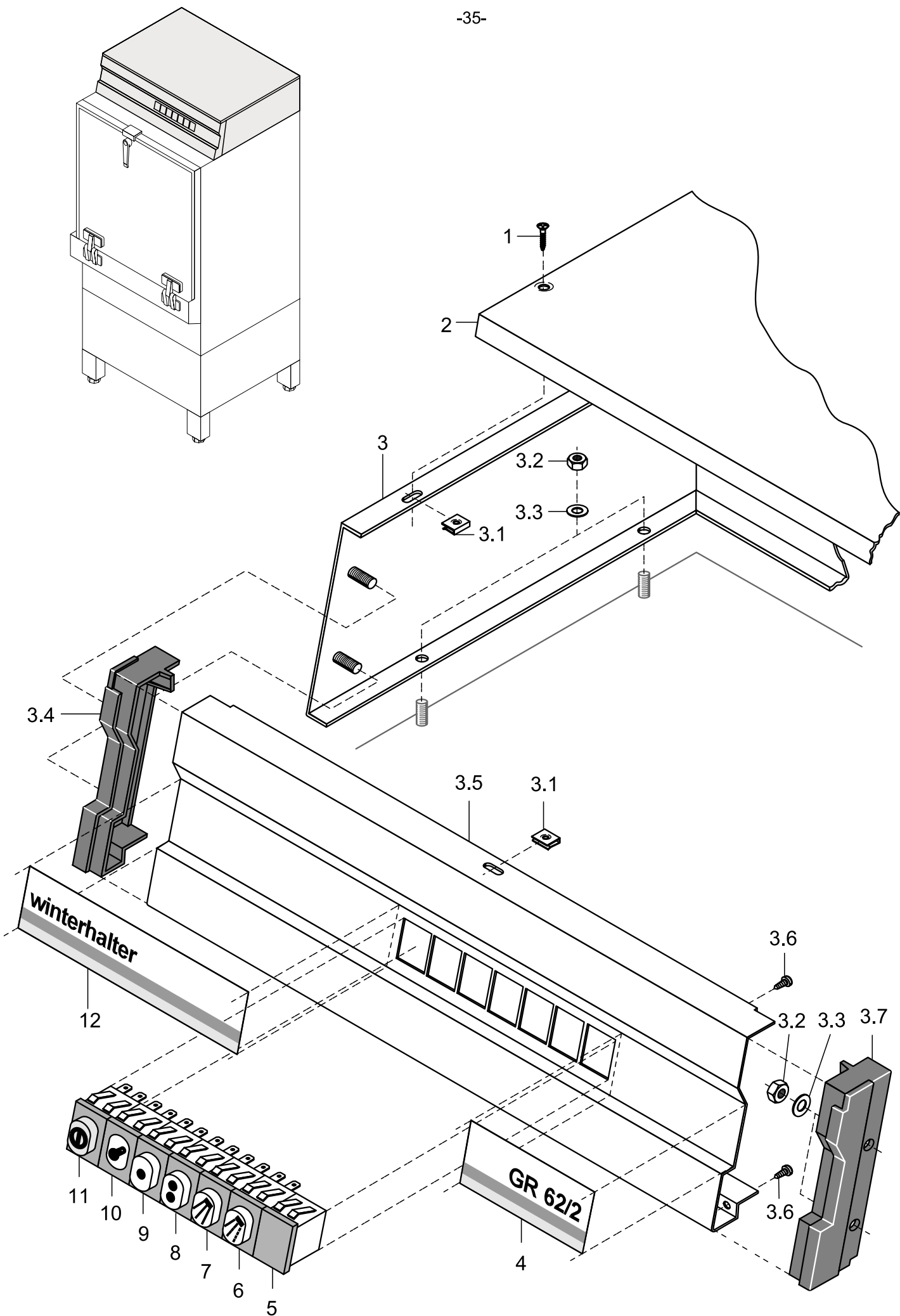

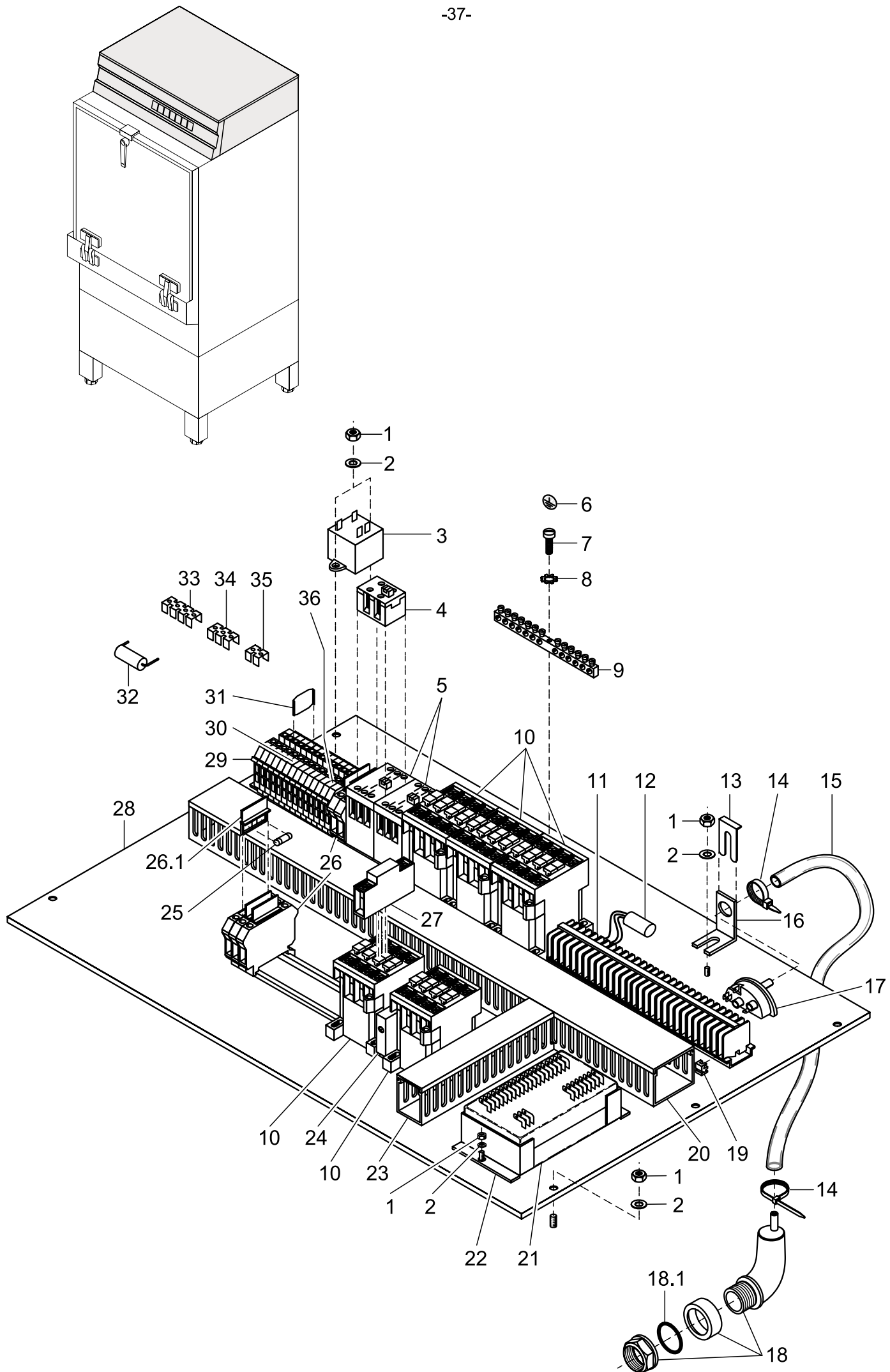

GR 62/2

Electrical parts II

Item	Designation	Part no.	Pc.	Notes
1	Hex nut; M 4 self-locking	21 05 300		
2	Washer; \varnothing 4.3 x \varnothing 12.0 x 1.0	22 05 300		
3	Radio interfer. suppr. capacitor; 3 x (0.47 μ F + 1M Ω)	31 13 072		
4	Contact module; LA1-SK11	31 04 130		
5	Contact relay; 220-240 V; 50/60 Hz; CA2-SK20	31 04 115	2	
6	Earth symbol; green/yellow	31 09 096		
7	Pan-head screw; M 4 x 8	20 10 210		
8	Toothed lock washer; J 4.3	23 01 002		
9	Terminal block; PE KLB 12/SEV	31 09 094		
10	Contact relay; A16; 220-255V; 50/60Hz	31 04 162	5	
	Contact relay; A16; 200V; 50/60Hz	31 04 163		Japan
11	Strip terminal BK 4 - FS/FS	31 09 025	30	
12	Radio interf. suppression capacitor; 0.1+ 2 x 0.01 μ F	31 13 071		
13	Clamping spring for level controller	31 26 001		
14	Cable binder; 162 x 2.5	31 20 014		
15	Hose; nom. dia. 5 x 1.5 x 1030	40 01 024		per metre
16	Support; level controller	61002345		
17	Level controller; 60/100 \pm 5	31 26 020		orange
18	Air chamber cpl.	55 04 024		incl. item 18.1
18.1	O-ring; 24 x 3.0	27 07 026		
19	Straps	31 09 012	8	
20	Cable duct 60 x 40 x 600	65002771		
21	Electr. Programme switch; EPS 1.1; 230V	31 05 131		
	Electr. Programme switch; EPS 1.1; 200V; 240V	31 05 132		
22	Support; programme switch	61003088	2	
23	Cable duct 60 x 25 x 180	65002772		
24	Closing delay device; 1 - 60 s	31 13 066		
25	Fine-wire fuse; 250V; 6.3A	31 11 043	4	
	Fine-wire fuse; 250 A; 2.0A	31 11 042	6	power supply: 200V / 230V
	Fine-wire fuse; 250V; 1.0A	31 11 039	5	power supply: 400V
26	Universal fuse terminal; UK-Si	31 09 063	5	incl. item 26.1
26.1	Fused plug	31 09 072		
27	Auxiliary switch; make contact	31 04 166		
28	Switch box base	65002956		
29	Universal terminal; USLKG 10 gn-ye	31 09 059	2	
30	Universal terminal, grey UK 10	31 09 057	10	
31	Isolating disk TS-K	31 09 066	3	
32	Radio interference suppr. capacitor; 33000pF; 250V	31 13 073		
33	Fixed bridge; FB 4-8	31 09 148		
34	Fixed bridge; 3-pin; FB 10-8	31 09 138	3	
35	Fixed bridge; 2-pin; FB 10-8	31 09 128		
36	Universal terminal; UK 10 blue	31 09 058	2	

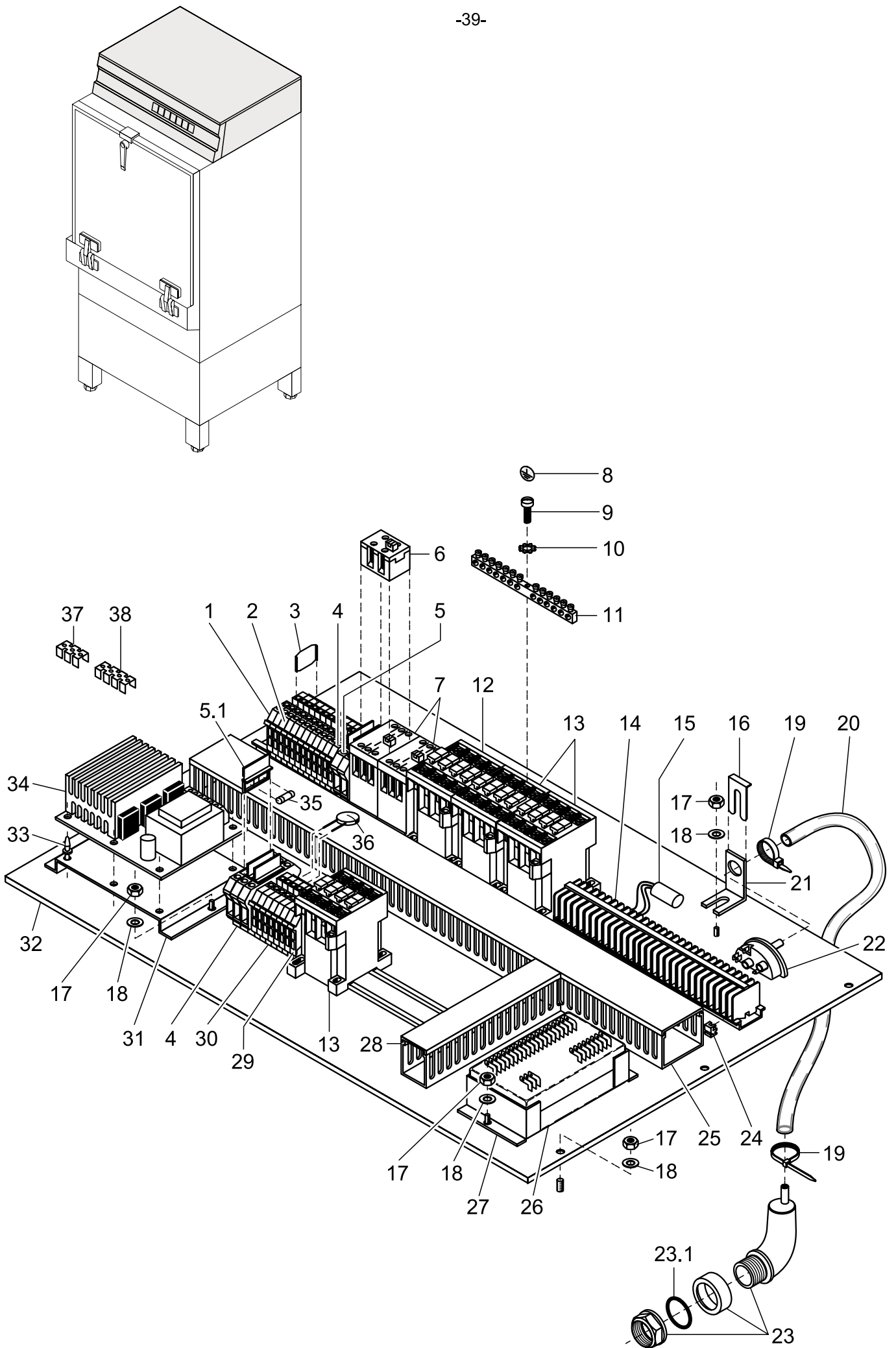

GR 62/2

Mach.-no.: ⇒ 342 720

Electrical parts II - with soft starter

Item	Designation	Part no.	Pc.	Notes
1	Universal terminal; USLKG 10 gn-ye	31 09 059	2	
2	Universal terminal, grey UK 10	31 09 057	10	
3	Isolating disk TS-K	31 09 066	2	
4	Universal terminal; UK 10 blue	31 09 058	2	
5	Universal fuse terminal; UK-Si	31 09 063	5	incl. item 5.1
5.1	Fused plug	31 09 072		
6	Contact module LA1-SK11	31 04 130		
7	Contact relay; 220-240 V; 50/60 Hz; CA2-SK20	31 04 115	2	
8	Symbol „Potential Earth“; green/yellow	31 09 096		
9	Pan-head screw; M 4 x 8	20 10 210		
10	Toothed lock washer; J 4.3	23 01 002		
11	Terminal block; PE KLB 12/SEV	31 09 094		
12	Contact; A30; 220-255V; 50/60Hz	31 04 164		
	Contact; A30; 3H; 1Ö; 200V; 50/60Hz	31 04 165		Japan
13	Contact; A16; 220-255V; 50/60Hz	31 04 162	3	
	Contact; A16; 200V; 50/60Hz	31 04 163		
14	Strip terminal BK 4 - FS/FS	31 09 025	30	
15	Radio interf. suppression capacitor; 0.1+ 2 x 0.01 µF	31 13 071		
16	Clamping spring for level controller	31 26 001		
17	Hex nut; M 4 self-locking	21 05 300		
18	Washer; ø 4.3 x ø 12.0 x 1.0	22 05 300		
19	Cable binder; 162 x 2.5	31 20 014		
20	Hose; nom. dia. 5 x 1.5	40 01 024		per metre
21	Support; level controller	61002345		
22	Level controller; 60/100 ± 5	31 26 020		orange
23	Air chamber cpl.	55 04 024		incl. item 23.1
23.1	O-ring; 24 x 3.0	27 07 026		
24	Straps	31 09 012	6	
25	Cable duct 60 x 40 x 600	65002771		
26	Electr. Programme switch; EPS 1.1; 230V	31 05 131		
	Electr. Programme switch; EPS 1.1; 200V; 240V	31 05 132		
27	Support; programme switch	61003088	2	
28	Cable duct 60 x 25 x 180	65002772		
29	Earth symbol; green/yellow	31 09 096		
30	Universal terminal; UK5N grey	31 09 049	9	
31	Bracket	65003258		
32	Switch box base	65002956		
33	Spacer; printed board	31 13 044	6	
34	Conventional creep-start conversion kit	55 28 196		
35	Fine-wire fuse; 250V; 6.3A	31 11 043	4	
	Fine-wire fuse; 250 A; 2.0A	31 11 042	6	power supply: 200V / 230V
36	Varistor; 400 V	31 13 098	3	
	Varistor; 200-220V	31 13 100	3	Japan
37	Fixed bridge; FB 10-8	31 09 138	2	3-pin
38	Fixed bridge; FB 4-8	31 09 148		4-pin

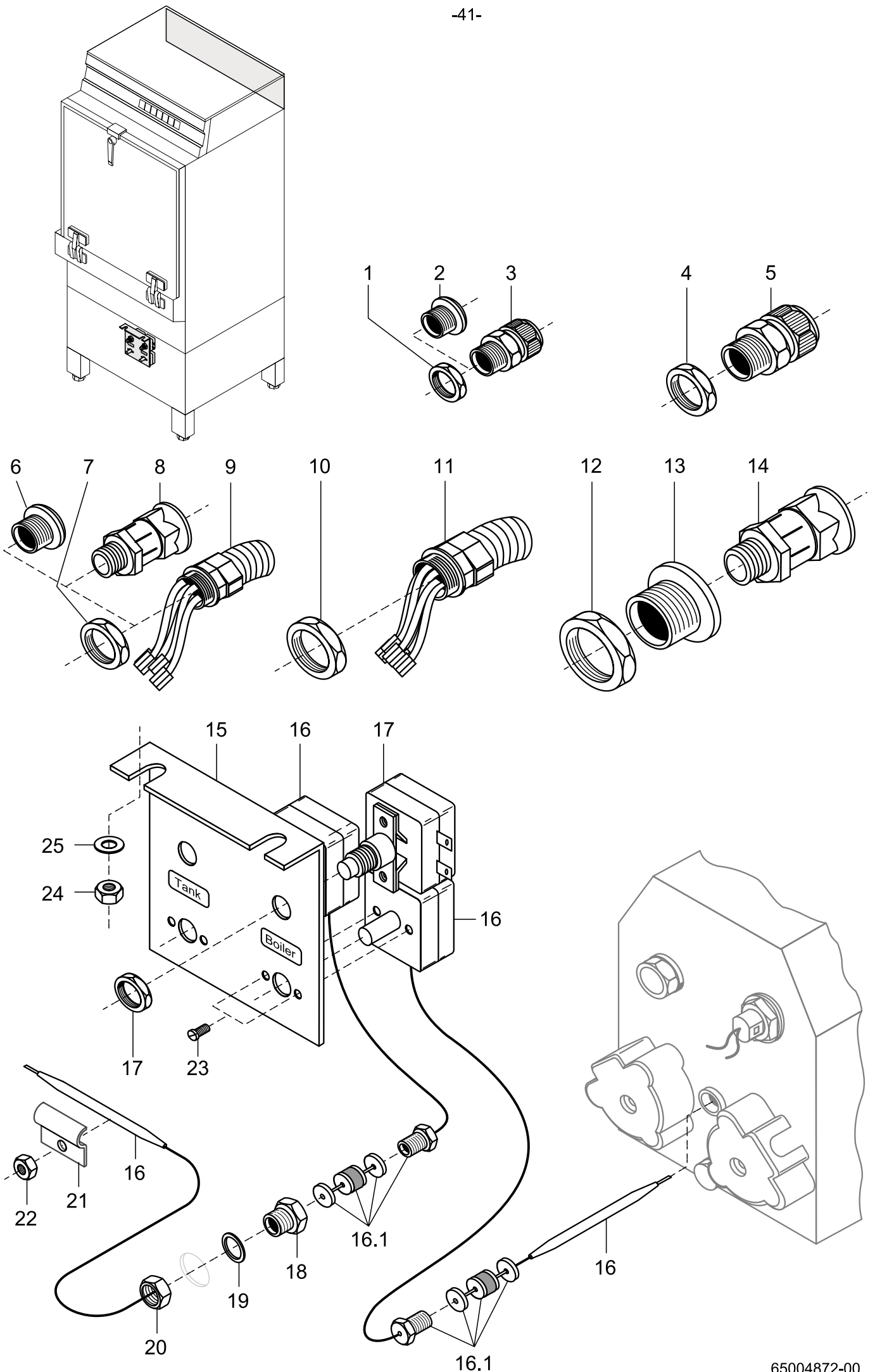

GR 62/2

Electrical parts III

Item	Designation	Part no.	Pc.	Notes
1	Hex nut; PG 9	31 10 043	3	
2	Screw cap; PG 9	31 10 021	2	
3	Cable gland; PG 9	31 10 042		
4	Hex nut; PG 11	31 10 045		
5	Cable gland; PG 11	31 10 044		
6	Screw cap; PG 16	31 10 025		
7	Hex nut; PG 16	31 10 110	4	
8	Cable gland; PG 16 with strain relief device	31 10 049	3	
9	Harness; control	65002950		
10	Hex nut; PG 21	31 10 071		
11	Harness; three-phase current	65002951		
12	Hex nut; PG 29	31 10 047		
13	Reducing ring; KUK 29/21	31 10 091		
14	Cable gland; PG 21 with strain relief device	31 10 070		
15	Thermostat support	65002459		
16	Thermostat; 1750mm long	31 25 013	2	incl. item 16.1
16.1	Stuffing box gland	31 25 012		
17	Safety thermostat; 140°C - 10K "OFF"	31 25 030		
18	Stuffing box for thermostat; M 14 x 1	31 25 001		
19	Seal; ø 14.2 x ø 20 x 2.0	27 09 036		
20	Hex nut; M 14 x 1 x 5	31 25 002		
21	Thermostat clip	55 19 011		
22	Hex nut; M 4 self-locking	21 05 300		
23	Pan-head screw; M 4 x 8	20 10 309		
n.p.	Lock washer; B 8	23 03 301		
24	Hex nut; M 5 self-locking	21 05 302		
25	Washer; ø 5.3 x ø 12 x 0.8	22 02 213		
n.p.	Feeder cable; 5 x 2.5 mm ² x 3000	31 23 132		
n.p.	Power supply cable; 5 x 4.0 mm ² x 3000	31 23 139		
n.p.	Power supply cable; 4 x 6.0 mm ² x 3000	31 23 130		
n.p.	Cable; 4 x 2.5 mm ² x 2400	65000273		pump
n.p.	Cable; 4 x 2.5 mm ² x 2400	65000274		heating element; soft starter
n.p.	Wire assortment; switch box	65002946		
n.p.	Wire assortment; final assembly	65002947		
n.p.	Additional wires; control box	65003588		
n.p.	Additional wire assortment; control box	80001820		

