



# First Choice Group

SPARE PARTS DIAGRAM FOR



## Char Broiler

BCB600

BCB900

BCB1200

BCB1500

BCB1800

First Choice Group  
Blakeney Way, Kingswood Lakeside  
Cannock, Staffs, WS11 8LD  
TEL: 01543 577778 FAX: 01543504141  
Email: [enquires@firstchoice-cs.co.uk](mailto:enquires@firstchoice-cs.co.uk)  
Web: [www.firstchoice-cs.co.uk](http://www.firstchoice-cs.co.uk)

# BONNET



## Catalogue of Replacement Parts Catalogue de Pièces de Rechange Ersatzteilkatalog



## BCB600 to BCB1800 Bonnet Char Broiler

PLE 200538 A-04-10  
EU 8389

# Internal Memo

BONNET

HOBART

To	Sales Force, Service, Installs, technical & Administration	From	Paul Godfrey
			UK Food Equipment Manager
cc	Ian Garner, Steve Wallace & Jane Gray	Tel	07831 666859
Date	25 <sup>th</sup> Aug 2011		
Pages	1	Email	Paul.Godfrey@hobartuk.com
<b>RE - Old SCB stands with new BCB Char-broilers</b>			

Ladies and Gentlemen,

Although we have sold in excess of 100 units of the new BCB we have had 3 issues where units have not fitted old stands.

After further investigation it appears some of the older stands approx 5 yrs plus may not fit due to the design.

It is not easy to identify stands so please use the diagram below that shows the BCB leg dimensions from front to back as 490 mm to the centre of each leg; width dims are the same as the appliance as the legs are level with the sides – to avoid further problems you should check this on your site survey; or if a site survey cannot be done we MUST sell a new stand.

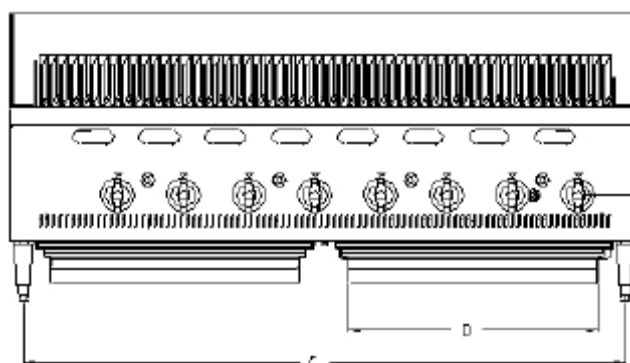
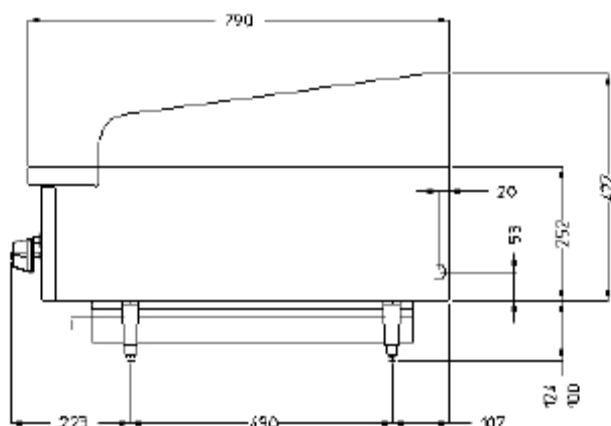

Many thanks

Paul Godfrey

THIS DOCUMENT CONTAINS PROPRIETARY AND CONFIDENTIAL DATA OF HOBART CORPORATION OR ITS SUBSIDIARIES. NO DISCLOSURE, REPRODUCTION OR USE OF ANY PART THEREOF MAY BE MADE WITHOUT THE WRITTEN PERMISSION OF HOBART CORPORATION.  
 CE DOCUMENT CONTIEN DES DONNÉES CONFIDENTIELLES APPARTENANT À HOBART CORPORATION OU À SES FILIALES. AUCUNE DIVULGATION, REPRODUCTION OU UTILISATION DE TOUT OU PARTIE DE CE DOCUMENT NE PEUT ÊTRE FAITE SANS L'AUTORISATION ÉCRITE DE HOBART.  
 DAS ÜBERBEREICHT AN DIESER ZEICHNUNG VERBIBT BEI DER HOBART CORPORATION ODER EINER IHRER TOCHTERGESellschaften. JEDE NICHT VON UNS SCHRIFTLICH GENEHMIGTE BENÜTZUNG, VERVIelfÄLTIGUNG, ÜBERLASSUNG AN DRITTE USW. IST STRAFBAR UND MACHT SCHADENSATFELTIG.

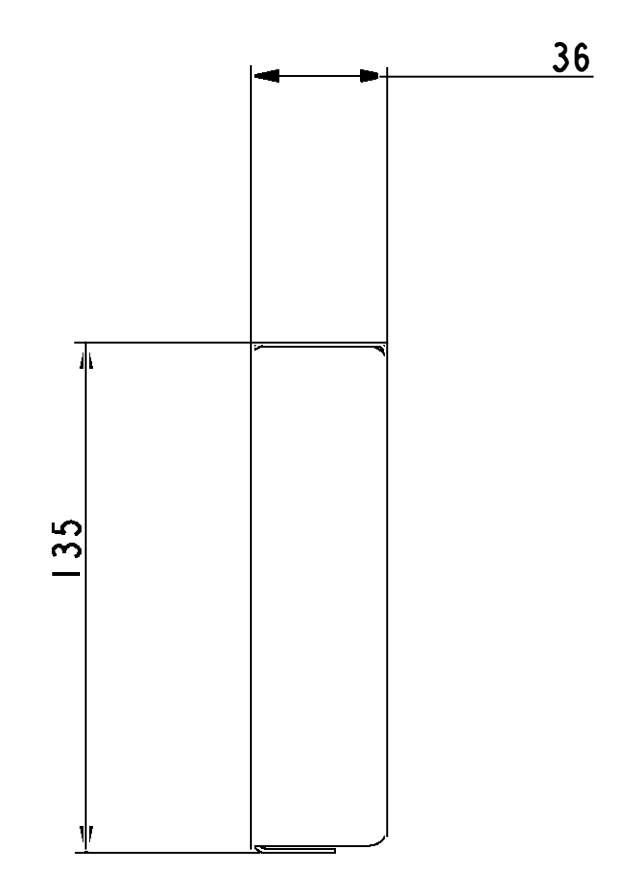
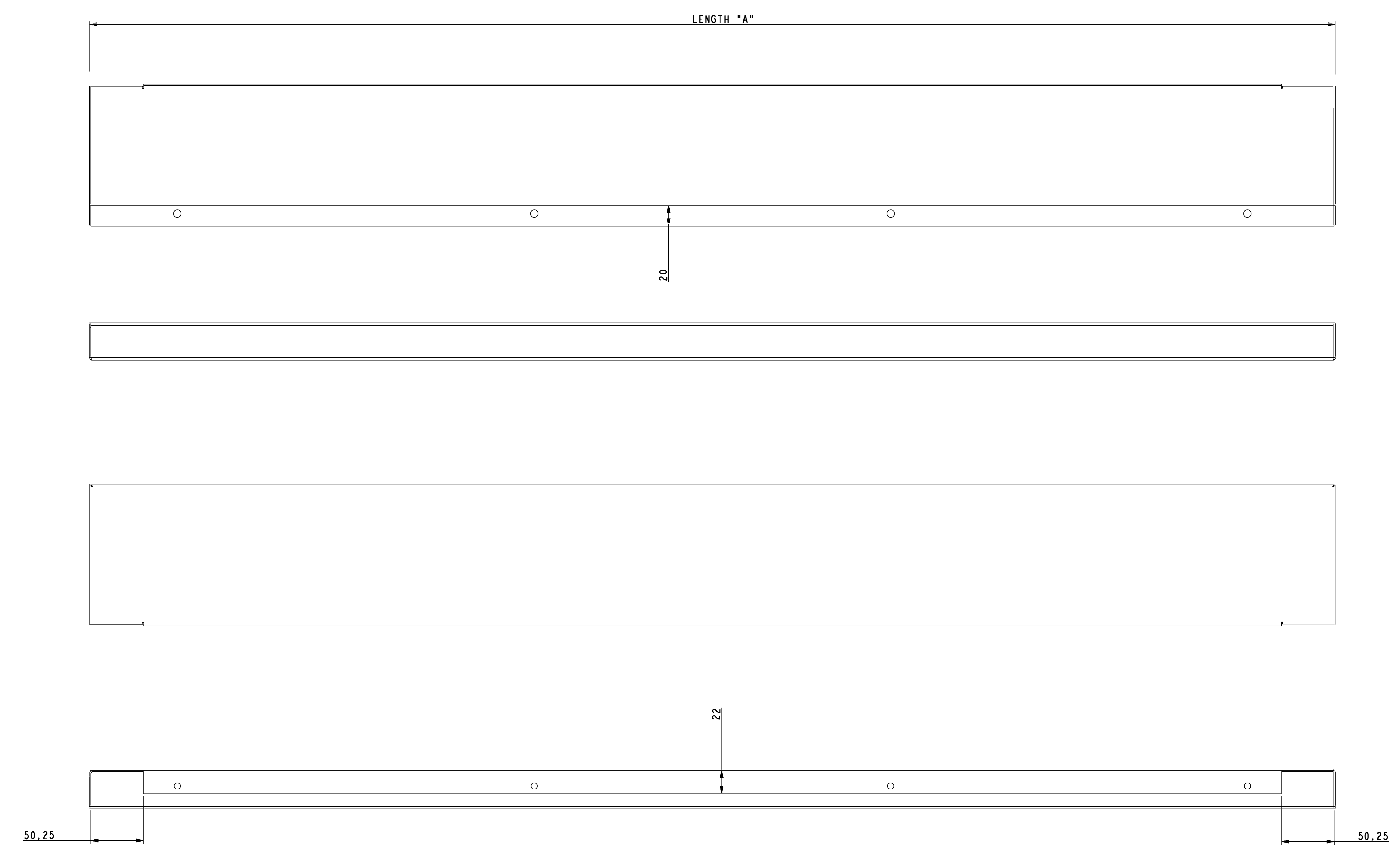

PART No	LENGTH "A"
00-739830-1	643.0
00-739830-2	914.0
00-739830-3	1185.0
00-739830-4	1535.0
00-739830-5	1845.0

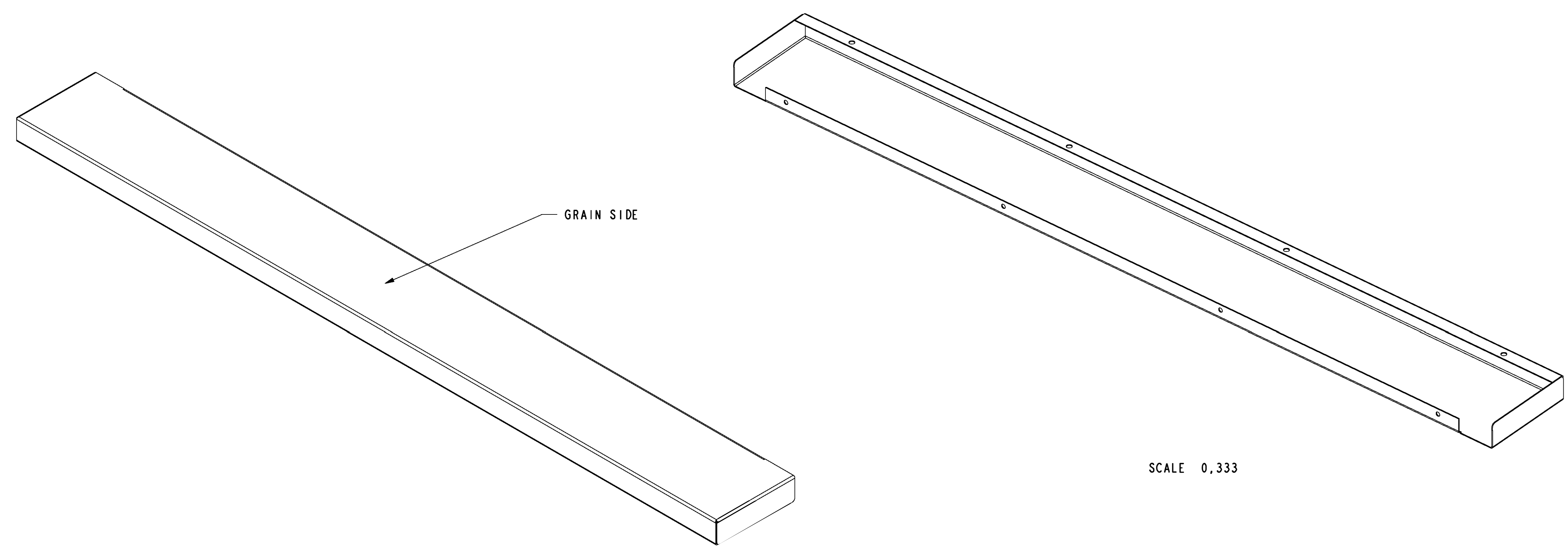

REF : DCC UK CAD	REMOVE ALL BURS AND SHARP EDGES REPORT ERRORS IMMEDIATELY	MATERIAL 1.2mm BSEN10088/2 1.4016
TOLERANCES NOT SPECIFIED TOLERANCES NON SPECIFIEES NICHT TOLERANZ GEMÄSS	DO NOT SCALE DRAWING	FINISH DP1(320)/VC1
(EXCEPT HOLES) EXCEPT LOS TROUS ±0.5 mm FLOCHER AUSGESCHLOSSEN!	STOCK SIZE -- STANDARD COMMERCIAL TOLERANCES APPLY	DESIGNATION SCG
HOLES TOLERANCES TOLERANCES DE TROUS LOCH-TOLERANZEN	ENLÈVER TOUTES LES SAUVURES ET LES ANGES VIFS RAPPORTER LES ERREURS IMMÉDIATEMENT	PART / MOLD NO MODELL NR
0. — 3 +10.081-10.03 3. — 6 +10.101-10.05 6. — 18 +10.131-10.05 18. — +10.251-10.05	NE PAS PRÉCISER DES COTES L'ÉCHELLE	DATE 14.08.09
CHAMFERS (C) CHAFFREIN (C) 0.5 — 1 x 45° — 50° FASER (C)	ANGLES WINKEL ALLE KANTEN ENTGRATEN	DATE 10.12.09
	FEHLER SOFORT MELDEN NICHT MASSSTÄBLICH ROMMATERIAL-TOLERANZEN VERBODEN!	DATE 19.10.09

ADD. ADJUTER, ADD-EMER   REMOUE, SUPPRIMER, ENTENER,   @MAG, ETAT, MAR.	DESIGNATION SCG	PART / MOLD NO MODELL NR
PART NAME PANEL - PLATE SUPPORT	DATE 14.08.09	SCALE 0,500
DESIGNER GJ	DATE 10.12.09	DATE 19.10.09
HOBART	E-00-739830	7

THIS DOCUMENT CONTAINS PROPRIETARY AND CONFIDENTIAL DATA OF HOBART CORPORATION OR ITS SUBSIDIARIES. NO DISCLOSURE, REPRODUCTION OR USE OF ANY PART THEREOF MAY BE MADE WITHOUT THE WRITTEN PERMISSION OF HOBART CORPORATION.  
 CE DOCUMENT CONTIENT DES DONNÉES CONFIDENTIELLES APPARTENANT À HOBART CORPORATION OU À SES FILIALES. AUCUNE DIVULGATION, RÉPRODUCTION, UTILISATION DE TOUT OU PARTIE DE CE DOCUMENT NE PEUT ÊTRE FAITE SANS L'AUTORISATION ÉCRITE DE HOBART CORPORATION.  
 DAS UNTERRECHT AN DIESER ZEICHNUNG VERBIBT BEI DER HOBART CORPORATION ODER EINER IHRER TOCHTERGESellschaften. JEDE NICHT VON UNS SCHRIFTLICH GENEHMIGTE BENÜTZUNG, Vervielfältigung, ÜBERLASSUNG AN DRITTE IST STRAFBAR UND MACHT SCHADENSATZFELTIG.

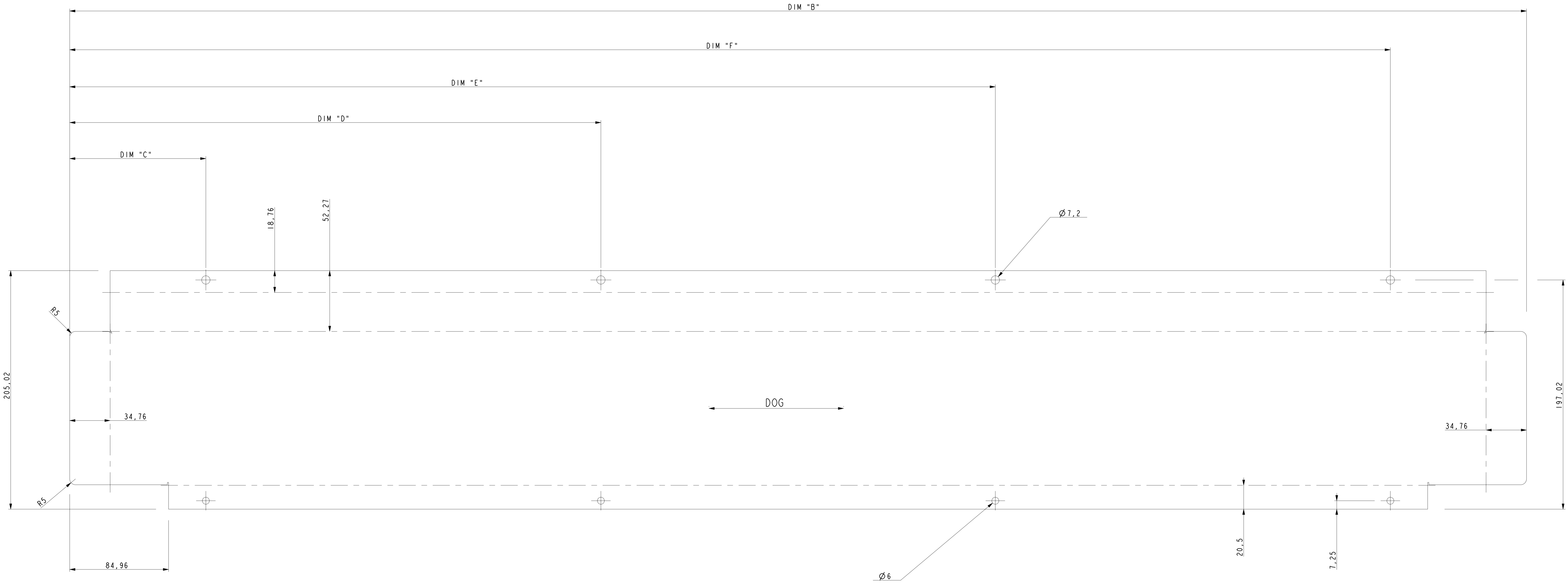

PART No	DIM "B"	DIM "C"	DIM "D"	DIM "E"	DIM "F"
00-739830-1	710	117	---	---	593
00-739830-2	981	117	---	---	864
00-739830-3	1252	117	456.5	795.5	1135
00-739830-4	1602	117	573	1029	1485
00-739830-5	1912	117	676	1236	1795

REF : DCC UK CAD	REMOVED ALL BURS AND SHARP EDGES REPORT ERRORS IMMEDIATELY	MATERIAL 1.2mm BSEN10088/2 1.4016
(EXCEPT HOLES) TOLERANCES NOT SPECIFIED TOLERANCES NON SPECIFIÉES NICHT TOLERANTE MASSE	DO NOT SCALE DRAWING STOCK SIZE -- STANDARD COMMERCIAL TOLERANCES APPLY	FINISH DPI(320)/ VC1
(EXCEPT HOLES) TOLERANCES DE TROUS LOCH-TOLERANZEN	ENLÈVER TOUTES LES BAVURES ET LES ANGLES VIFS RAPPORTER LES ERREURS IMMÉDIATEMENT	DESIGNATION SCG
0.3 ±0.08/-0.03 3. ±0.10/-0.05 6. ±0.15/-0.05 10. ±0.25/-0.05	RADII (R) RAYONS (R) 3-5 mm	PART / MOLD NO MODELL NR
CHAMFERS (C) CHAFFREIN (C) 0.5 - 1 x 40° - 50° FASEN (C)	ANGLES WINKEL 30°	DATE 14.08.09 TIME 10.12.09 PAGE 2 OF 7
	ALLE KANTEN ENTGRATEN FEHLER SOFORT MELDEN NICHT MASSTÄBLICH ROHMATERIAL-NACH TOLERANZEN VERMESSBAR	© HOBART E-00-739830

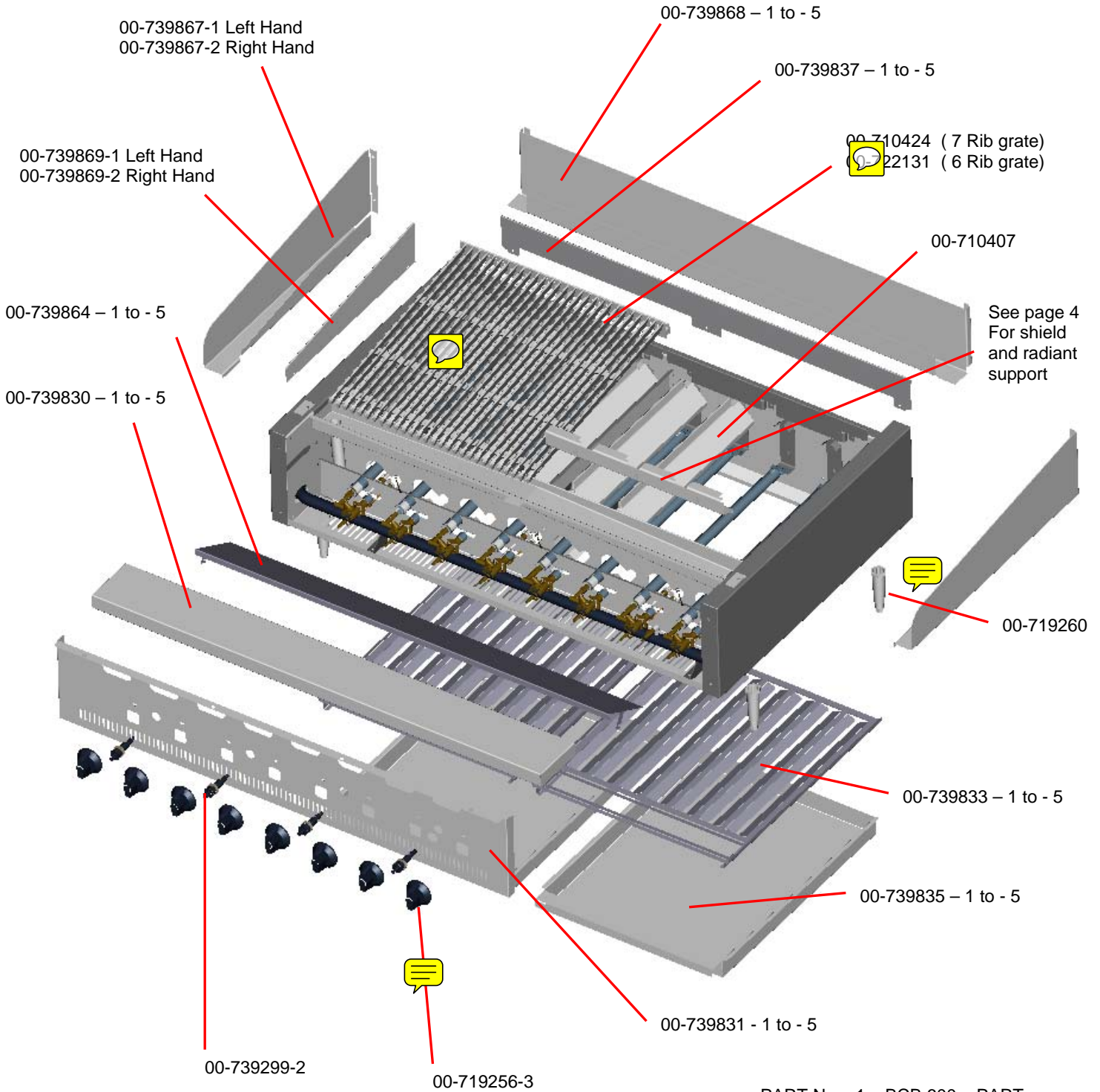

PART No - 1	BCB 600	PART
PART No - 2	BCB 900	PART
PART No - 3	BCB 1200	PART
PART No - 4	BCB 1500	PART
PART No - 5	BCB 1800	PART

## ENGINEERING TECHNICAL INSTRUCTION.

### ALTERNATIVE GAS KNOB FOR THE SCB SUPER CHAR BROILER.

#### HOBART PART NUMBER: 00-741081.

The original knob (part number 00-719255-3) shown in photograph 1 below and fitted to the SCB Char Broiler is no longer available. The knob has been superseded by the knob shown in photograph 2.

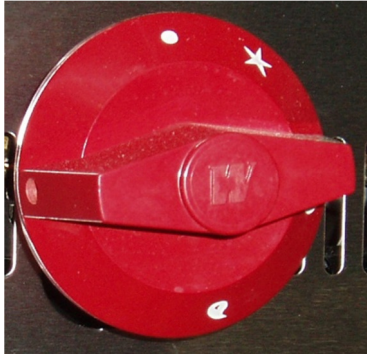

Photograph 1.



Photograph 2.

When assembling the new knob it may be necessary to adjust the valve stem tension to provide a secure push fit on the 'D'.

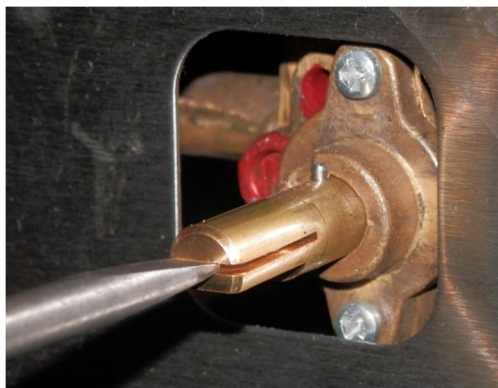

Use a flat bladed screw driver and gently prise open the slot in the valve stem as shown in photograph 3.

Push the knob onto the valve stem to check the fit.

Photograph 3.

	A					
03-16	EU 9219					

## Fixings

# BCB 600,900, 1200,1500 & 1800

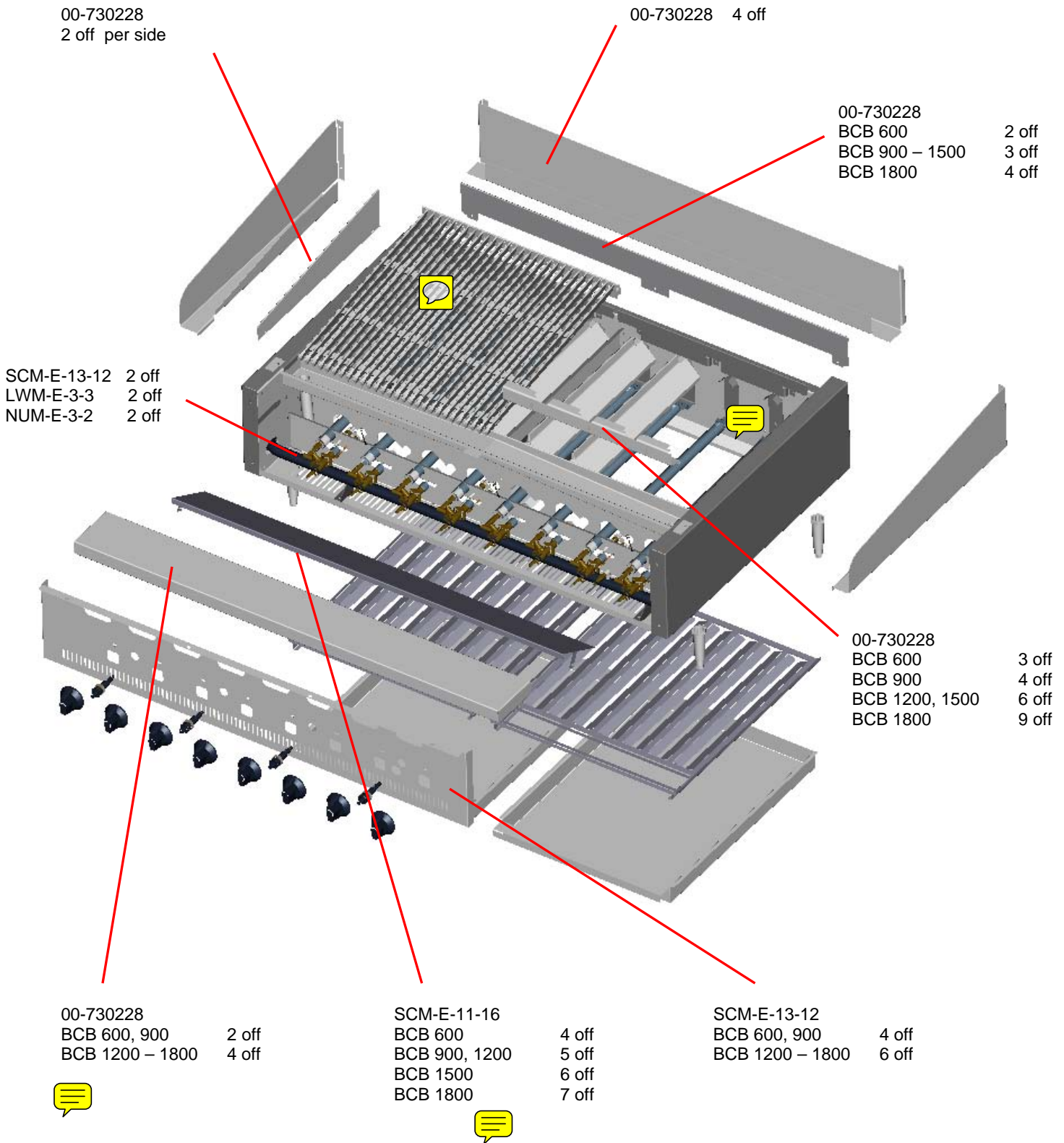





**Radiant supports and grates**

<b>Model</b>	<b>Shield and radiant support</b>	<b>00-710424 (7 rib grate)</b>	<b>00-722131 (6 rib grate)</b>
BCB 600	00-739895 (1 off)	4 off	none
BCB 900	00-739896 (2 off)	6 off	none
BCB 1200	00-739863 (2 off)	8 off	none
BCB 1500	00-739897 (2 off)	8 off	3 off
BCB 1800	00-739898 (3 off)	12 off	1 off

**Gas Jets**

<b>Gas</b>	<b>Main Jet</b>	<b>Pilot Jet</b>
Natural Gas	00-739808-3	00-739985-4
LPG Gas	00-739808-7	00-739985-2

Note:- Pilot valve assembly 00-739985 supplied with pilot jet 00-739985-4 ( natural gas)

**Gas regulator. 00-739029-#**

-1 = Nat Gas regulator 9 to 17 mbar

regulator spring 15-23 mbar (SP-E-1-17)

-2 = LPG regulator 22 to 31 mbar

**Accessories**

Grate cleaning tool 00-739857

Grate lifting tool 00-739858

**Installation and operation manual.**

PLE200537



Hobart trained service technicians strategically located at the listed Hobart branches are prepared to give you fast, efficient and reliable service. Protect your investment by having a Hobart inspection contract, which assures the continued, efficient operation of your Hobart machines, spares and accessories.

Nos techniciens qualifiés de S.A.V., stratégiquement répartis dans les établissements Hobart, sont prêts à vous offrir un service rapide, efficace et fiable. Protégez votre investissement en optant pour un contrat d'inspection Hobart afin d'assurer la continuité et la qualité de fonctionnement de vos appareils, pièces de rechange et accessoires Hobart.

An den aufgeführten, strategisch günstig gelegenen Standorten stehen qualifizierte Hobart-Kundendienstfachleute bereit, um Ihnen schnellen, effizienten und zuverlässigen Service zu bieten. Bewahren Sie Ihre Investition durch einen Hobart-Wartungsvertrag, der Ihnen jederzeit störungsfreien Betrieb sowie Ersatzteile und Zubehör garantiert.

**For further details contact:-**

### **HOBART SERVICE UK**

**SALES, SERVICE & SPARES: 0844 888 7777**

**Hobart UK  
Hobart House, 51 The Bourne,  
Southgate, London N14 6RT  
Tel: 020 8920 2800 Fax 020 8886 0450  
[www.hobartuk.com](http://www.hobartuk.com)**

Continued product improvement is a Hobart Still policy, specifications may change without notice.

### **HOBART SERVICE GERMANY**

**SERVICE-INFORMATIONEN UND -TELEFONNUMMERN.**

**Ausführliche Informationen erhalten Sie bei Ihrem Fachhändler, oder unter:**

**Service Tel. 01803 / 45 62 58 – [www.hobart.de](http://www.hobart.de) – [info@hobart.de](mailto:info@hobart.de) (innerhalb Deutschland)**

**HOBART behält sich das Recht vor, an allen Produkten Änderungen oder Verbesserungen ohne Ankündigungen vorzunehmen**

### **HOBART SERVICE FRANCE**

**Telephone : 0825021222**

**Hobart ayant une politique d'amélioration constante de ses produits, les spécifications peuvent changer sans préavis.**

# BONNET



## Catalogue of Replacement Parts Catalogue de Pièces de Rechange Ersatzteilkatalog



## BCB600 to BCB1800 Bonnet Char Broiler



Panels Trays and Grates

BCB 600,900,  
1200,1500 & 1800

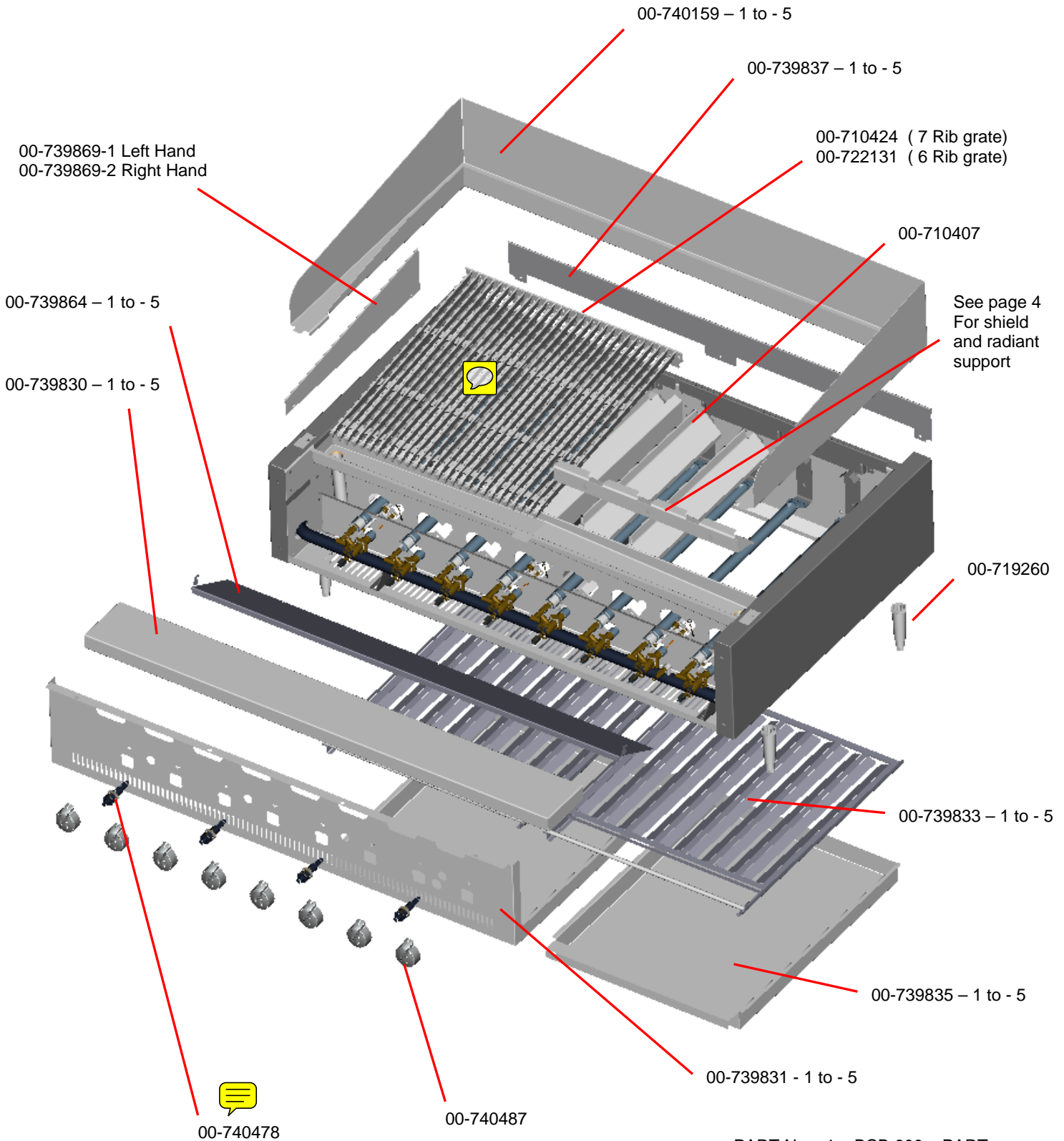

PART No – 1	BCB 600	PART
PART No – 2	BCB 900	PART
PART No – 3	BCB 1200	PART
PART No – 4	BCB 1500	PART
PART No – 5	BCB 1800	PART

DISTRIBUTION FULL <input type="checkbox"/> BARNSTAPLE <input checked="" type="checkbox"/> SERVICE <input checked="" type="checkbox"/>		<b>HOBART</b>			DATE 08.02.17	Page 1 of 3	ECN N° EU 9342	
MARKETING <input type="checkbox"/> EXPORT <input type="checkbox"/>		BARNSTAPLE UK ENGINEERING CHANGE NOTICE						
OTHERS BCB TECHNICAL FILE		STATUS		A. CHANGE IMMEDIATELY <input type="checkbox"/>	B. WITHOUT PROD DELAY <input checked="" type="checkbox"/>	C. RECORD CHANGE ONLY <input type="checkbox"/>	D. SEE SPECIAL INSTRUCTIONS <input type="checkbox"/>	
DISPOSITION CODE	SCRAP 1	REWORK 2	TRANSFER TO SERVICE 3	RETURN TO SUPPLIER 4	USE EXISTING STOCK 5	BALANCE STOCK 6	PLACE IN NON MOVING STOCK 7	ISSUED DATE 8 FEB 17.
ETI RELEASED NO		TSB REQUIRED NO		<input checked="" type="checkbox"/> EFFECT FROM SERIAL No			GAS APPLIANCE <input checked="" type="checkbox"/>	

ITEM	DRAWING / ML No	REV	TYPE	UOM	FIRST PIECE APPROVAL REQD	REPLACED No	OBS / SUPER	PART NAME, CHANGES & SPECIFIC REASON	QTY BEFR	QTY AFTR	LEVEL ONE ASSY ML- No	DISP CODE	ITEM MASTER	ROUTING	CNC PROGRAM	KAN BAN	SPARES MANUAL	BOX	
1	00-740979		B	EA		00-722131		REVERSIBLE GRATE - 6 GRID REPLACES GRATE, SLANTED SCB, 6 RIB	3	3	BCB1500-1 BCB1500-2 BCB1500-3 BCB1500-4 BCB1500-5 BCB1500-6 BCB1500-7 BCB1500-8 BCB1500-9	5							
2	00-740979		B	EA		00-722131		REVERSIBLE GRATE - 6 GRID REPLACES GRATE, SLANTED SCB, 6 RIB	1	1	BCB1800-1 BCB1800-2 BCB1800-3 BCB1800-4 BCB1800-5 BCB1800-6 BCB1800-7 BCB1800-8 BCB1800-9	5							

MODEL <b>BCB</b>	REASON REPLACE SLANTED GRATES WITH REVERSIBLE GRATES	Facilitator <i>D. BARKER</i>	On-line Eng <i>A. MORRELL</i>	Engineering <i>G. JENNINGS</i>	Originator A MORRELL
		Facilitator	Purchasing <i>C. C. HEALY</i>	Quality <i>D. BARKER</i>	Local Ref Number

**HOBART**BARNSTAPLE UK  
ENGINEERING CHANGE NOTICE

DATE

08-02-17

Page

2 of 3

ECN N°  
EU9342

ITEM	DRAWING / ML No	REV	TYPE	UOM	FIRST PIECE APPROVAL REQ'D	REPLACED No	OBS / SUPER	PART NAME, CHANGES & SPECIFIC REASON	QTY BEFR	QTY AFTR	LEVEL ONE ASSY ML- No	DISP CODE	ITEM MASTER	ROUTING	CNC PROGRAM	KAN BAN	SPARES MANUAL	BOM	
3	00-740980		B	EA		00-710424		REVERSIBLE GRATE - 7 GRID REPLACES GRATE,SLANTED SCB, 7 RIB	4	4	BCB600-1 BCB600-2 BCB600-3 BCB600-4 BCB600-5 BCB600-6 BCB600-7 BCB600-8 BCB600-9	5							
4	00-740980		B	EA		00-710424		REVERSIBLE GRATE - 7 GRID REPLACES GRATE,SLANTED SCB, 7 RIB	6	6	BCB900-1 BCB900-2 BCB900-3 BCB900-4 BCB900-5 BCB900-6 BCB900-7 BCB900-8 BCB900-9	5							
5	00-740980					00-710424		REVERSIBLE GRATE - 7 GRID REPLACES GRATE,SLANTED SCB, 7 RIB	8	8	BCB1200-1 BCB1200-2 BCB1200-3 BCB1200-4 BCB1200-5 BCB1200-6 BCB1200-7 BCB1200-8 BCB1200-9	5							
6	00-740980					00-710424		REVERSIBLE GRATE - 7 GRID REPLACES GRATE,SLANTED SCB, 7 RIB	8	8	BCB1500-1 BCB1500-2 BCB1500-3 BCB1500-4 BCB1500-5 BCB1500-6 BCB1500-7 BCB1500-8 BCB1500-9	5							



BARNSTAPLE UK  
ENGINEERING CHANGE NOTICE

DATE

08-02-17

Page  
3 of 3

ECN N°  
EU9342

ITEM	DRAWING / ML No	REV	TYPE	UOM	FIRST PIECE APPROVAL REQ'D	REPLACED No	OBS / SUPER	PART NAME, CHANGES & SPECIFIC REASON	QTY BEFR	QTY AFTR	LEVEL ONE ASSY ML- No	DISP CODE	ITEM MASTER	ROUTING	CNC PROGRAM	KAN BAN	SPARES MANUAL	BOM	
7	00-740980					00-710424		REVERSIBLE GRATE - 7 GRID REPLACES GRATE, SLANTED SCB, 7 RIB	12	12	BCB1800-1 BCB1800-2 BCB1800-3 BCB1800-4 BCB1800-5 BCB1800-6 BCB1800-7 BCB1800-8 BCB1800-9	5							



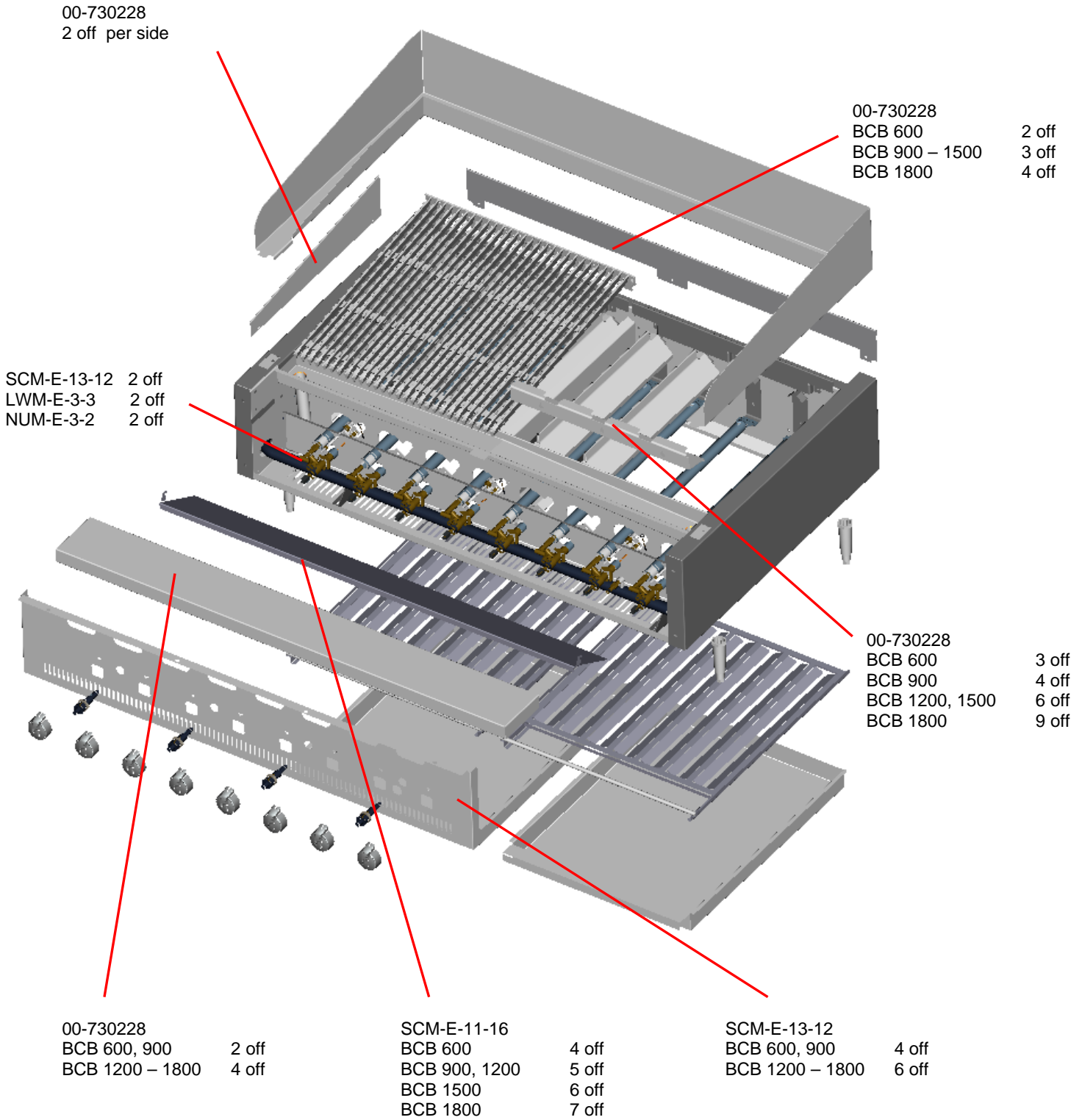

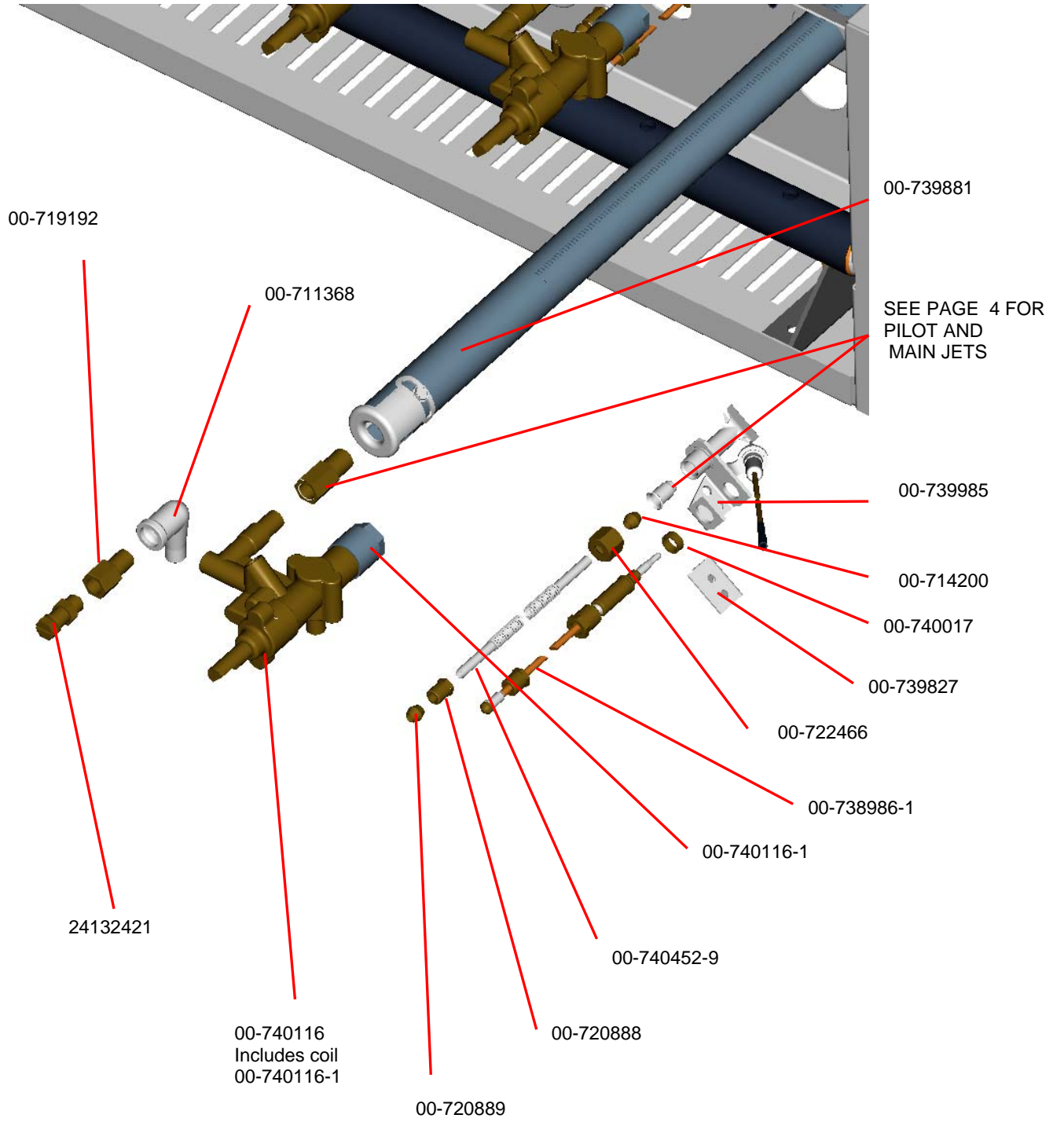

## Radiant supports and grates

Model	Shield and radiant support assembly	00-710424 (7 rib grate)	00-722131 (6 rib grate)
BCB 600	00-740086-600 (1 off)	4 off	none
BCB 900	00-740086-901 LH (1 off) 00-740086-902 RH (1 off)	6 off	none
BCB 1200	00-740086-1201 LH (1 off) 00-740086-1202 RH (1 off)	8 off	none
BCB 1500	00-740086-1501 LH (1 off) 00-740086-1502 RH (1 off)	8 off	3 off
BCB 1800	00-740086-1801 LH (1 off) 00-740086-1802 MID (1 off) 00-740086-1803 RH (1 off)	12 off	1 off

## Gas Jets

Gas	Main Jet	Pilot Jet
Natural Gas	00-739808-3	00-739985-4
LPG Gas	00-739808-7	00-739985-2

Note:- Pilot valve assembly 00-739985 supplied with pilot jet 00-739985-4 ( natural gas)

## Gas regulator.

LPG regulator 22 to 31 m bar, part number: 00-739029-2

## Gas conversion kit.

Natural gas to LPG conversion kit (suits all models) 00-740154

## Accessories

Grate cleaning tool 00-739857  
 Grate lifting tool 00-739858  
 Cleaning scoop 00-740064

## Installation and operation manual.

PLE200537

L986EL-00-0

THIS DOCUMENT CONTAINS PROPRIETARY AND CONFIDENTIAL DATA OF HOBART CORPORATION OR ITS SUBSIDIARIES NO DISCLOSURE, REPRODUCTION OR USE OF ANY PART THEREOF MAY BE MADE WITHOUT WRITTEN PERMISSION OF HOBART.  
 CE DOCUMENT CONTIENT DES DONNEES CONFIDENTIELLES APPARTENANT A HOBART CORPORATION OU A SES FILIALES. AUCUNE DIVULGATION, REPRODUCTION OU UTILISATION DE TOUT OU PARTIE DE CE DOCUMENT NE PEUT ETRE FAITE SANS L'AUTORISATION ECRITE D'HOBART.  
 DAS URHEBERRECHT AN DIESER ZEICHNUNG VERBEIBT BEI DER HOBART CORPORATION ODER EINER IHRER TOCHTERGESSELLSCHAFTEN. JEDE NICHT VON UNS SCHRIFTLICH GENEHMIGTE BENUTZUNG, VERVIELFALTIGUNG, UBERLASSUNG AN DRITTE USW IST STRAFBAR UND MACHT SCHADENERSATZPFLICHTIG

B	RELEASED TO PRODUCTION	14.12.09	EU 8334
C	VIS. CORRECTED (00-739807)	17.05.10	EU 8401

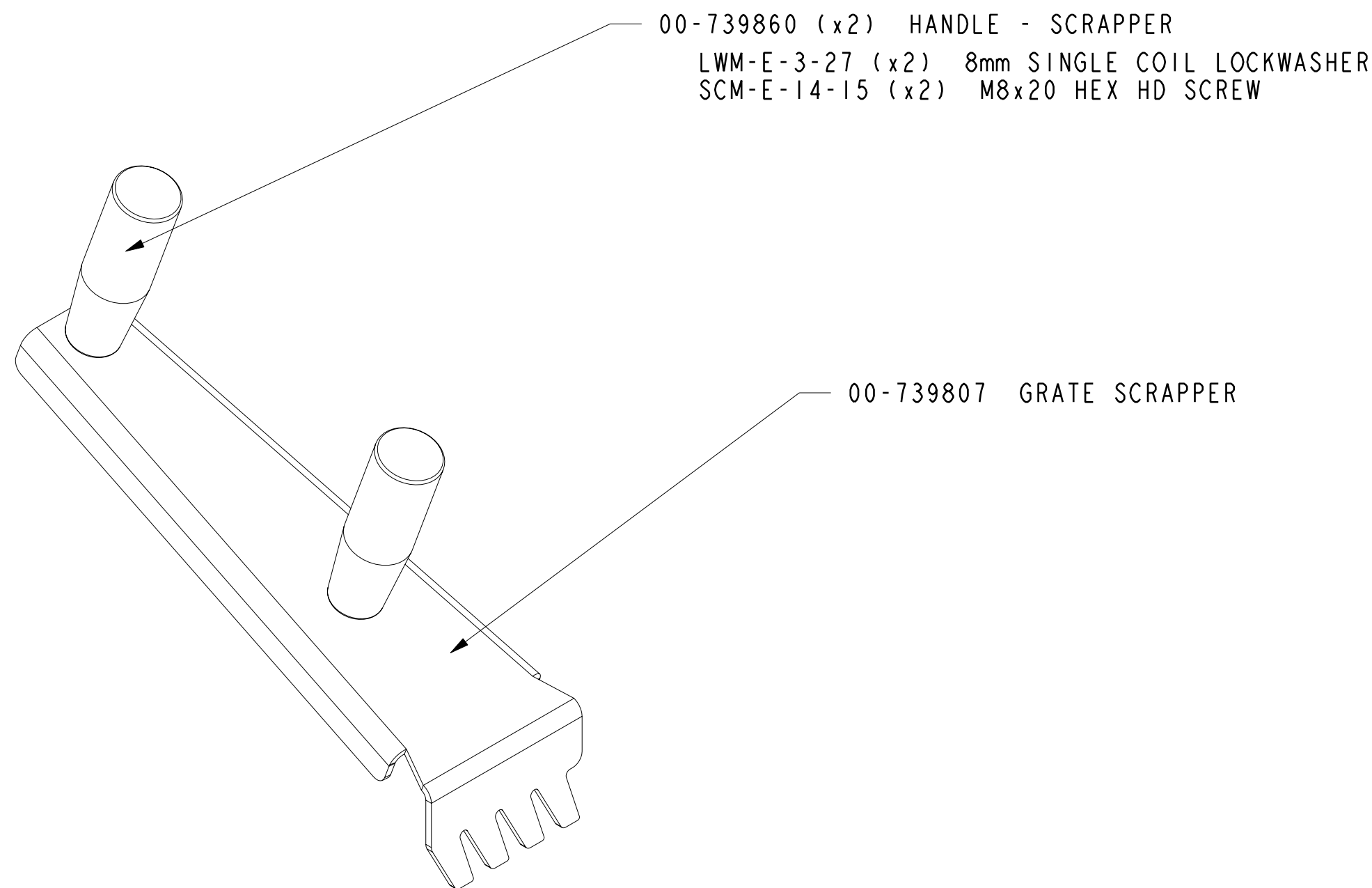

REF : DCC UK CAD	REMOVE ALL BURRS AND SHARP EDGES	MATERIAL
TOLERANCES NOT SPECIFIED TOLERANCES NON SPECIFIEES NICHT TOLERIERTE MASSE	REPORT ERRORS IMMEDIATELY	SEE NOTES
(EXCEPT HOLES) (EXCEPT LOS TROUS) ± mm (LOCHER AUSGESCHLOSSEN)	DO NOT SCALE DRAWING	FINISH
HOLE TOLERANCES TOLERANCES DE TROUS LOCH-TOLERANZEN	STOCK SIZE :- STANDARD COMMERCIAL TOLERANCES APPLY	
0, 3 (+0,08(-)0,03)	ENLEVER TOUTES LES BAVURES ET LES ANGLES VIFS	
3, 6 (+0,10(-)0,05)	RAPPORTER LES ERREURS IMMEDIATEMENT	
6, 16 (+0,13(-)0,05)	NE PAS PRENDRE DES COTES L'ECHELLE	
16, (+0,25(-)0,05)	SUREPAISSEURS-APPLIQUER LES TOLERANCES STD. DU COMMERCE	
RADI (R) RAYONS (R) RADIEN (R) 3-5 mm	ALLE KANTEN ENTGRATEN	
ANGLES WINKEL ±1°	FEHLER SOFORT MELDEN	
CHAMFERS (C) CHANFREIN (C) 0.5 x 40° 50° FASEN (C)	NICHT MASSTABLICH	
	ROHMATERIAL-NORM TOLERANZEN VERWENDBAR	

ZONE	LTD INVOICE AND NO	REVISIONS MODIFICATIONS ÄNDERUNGEN	DATE DATUM	ECH NO
ADD. AJOUTER. ADDIEREN		REMOVE. SUPPRIMER. ENTFERNEN.	WAS. ETAIT. WAR.	
PART NAME GRATE SCRAPER ASSEMBLY				
DESIGNATION				
BENENNUNG				
FIRST USED ON MACHINE VERWENDDUNG	SCG	PAT / MOLD NO		
NET WEIGHT ENDEWICHT		MODELE		
GROUP GRUPPE		MODELL NR		
DATE DATE	CNK	DATE DATE	14.12.09	SCALE ECHELLE MASSSTAB
DATE DATE	GJ	DATE DATE	15.12.09	0,500
DATE DATE		DATE DATE		1
HOBART		C-00-739857		REV ÄNDERE c

LS86EL-00-0

THIS DOCUMENT CONTAINS PROPRIETARY AND CONFIDENTIAL DATA OF HOBART CORPORATION OR ITS SUBSIDIARIES NO DISCLOSURE, REPRODUCTION OR USE OF ANY PART THEREOF MAY BE MADE WITHOUT WRITTEN PERMISSION OF HOBART.  
 CE DOCUMENT CONTIENT DES DONNEES CONFIDENTIELLES APPARTENANT A HOBART CORPORATION OU A SES FILIALES. AUCUNE DIVULGATION, REPRODUCTION OU UTILISATION DE TOUT OU PARTIE DE CE DOCUMENT NE PEUT ETRE FAITE SANS L'AUTORISATION ECRITE D'HOBART.  
 DAS URHEBERRECHT AN DIESER ZEICHNUNG VERBEIBT BEI DER HOBART CORPORATION ODER EINER IHRER TOCHTERGESSELLSCHAFTEN. JEDE NICHT VON UNS SCHRIFTLICH GENEHMIGTE BENUTZUNG, VERVIELFALTIGUNG, UBERLASSUNG AN DRITTE USW IST STRAFBAR UND MACHT SCHADENERSATZPFLICHTIG

B	RELEASED TO PRODUCTION	14.12.09	EU 8334
C	VIS. CORRECTED (00-739807)	17.05.10	EU 8401

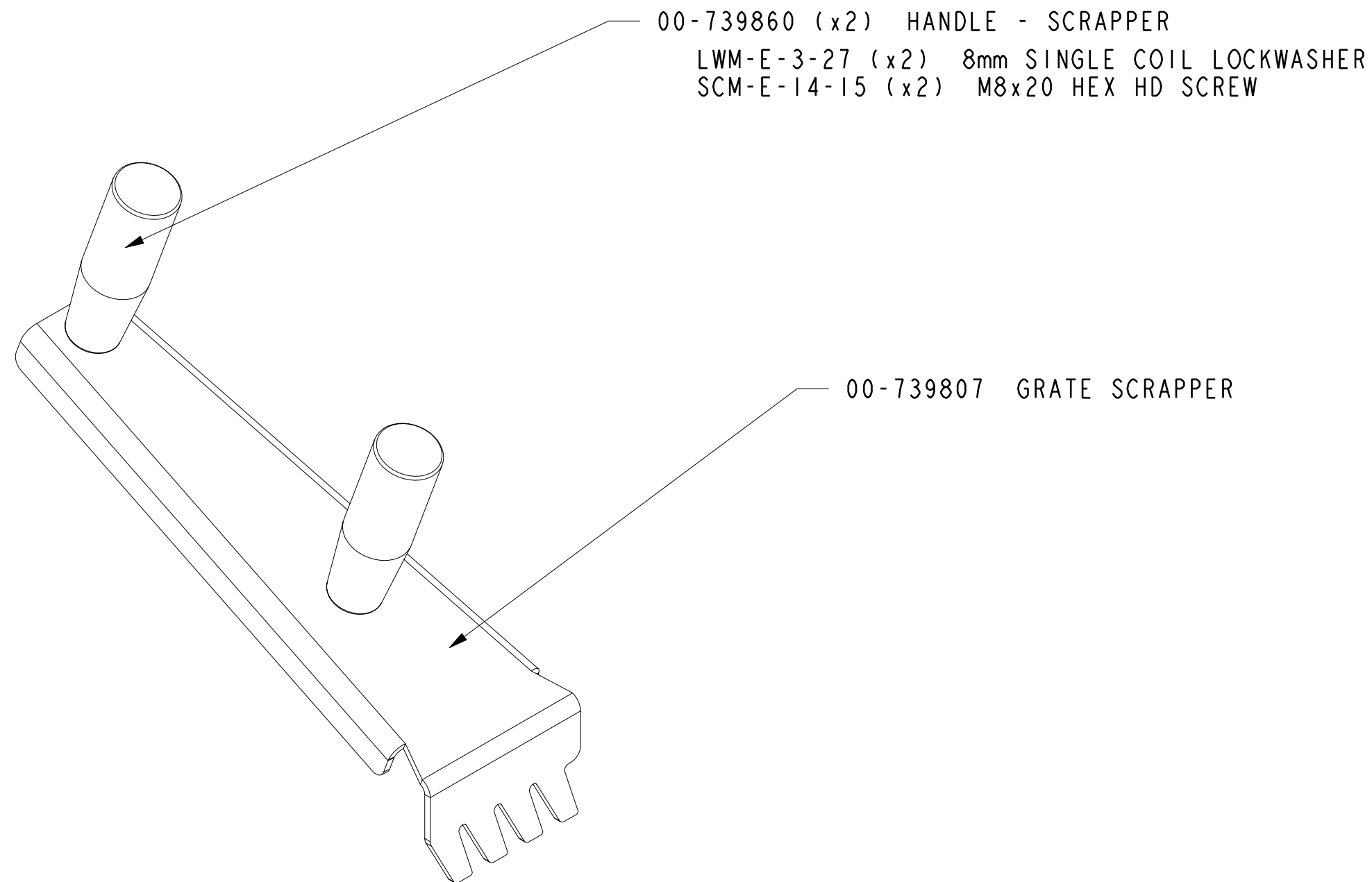

REF : DCC UK CAD	REMOVE ALL BURRS AND SHARP EDGES	MATERIAL
TOLERANCES NOT SPECIFIED TOLERANCES NON SPECIFIEES NICHT TOLERIERTE MASSE	REPORT ERRORS IMMEDIATELY	SEE NOTES
(EXCEPT HOLES) (EXCEPT LOS TROUS) ± mm (LOCHER AUSGESCHLOSSEN)	DO NOT SCALE DRAWING	FINISH
HOLE TOLERANCES TOLERANCES DE TROUS LOCH-TOLERANZEN	STOCK SIZE :- STANDARD COMMERCIAL TOLERANCES APPLY	
0, 3 (+0,08(-)0,03)	ENLEVER TOUTES LES BAVURES ET LES ANGLES VIFS	
3, 6 (+0,10(-)0,05)	RAPPORTER LES ERREURS IMMEDIATEMENT	
6, 16 (+0,13(-)0,05)	NE PAS PRENDRE DES COTES L'ECHELLE	
16, (+0,25(-)0,05)	SUREPAISSEURS-APPLIQUER LES TOLERANCES STD. DU COMMERCE	
RADI (R) RAYONS (R) RADIEN (R) 3-5 mm	ALLE KANTEN ENTGRATEN	
ANGLES WINKEL ±1°	FEHLER SOFORT MELDEN	
CHAMFERS (C) CHANFREIN (C) 0.5 x 40° 50° FASEN (C)	NICHT MASSTABILICH	
	ROHMATERIAL-NORM TOLERANZEN VERWENDBAR	

ZONE	LTD INVOICE AND NO	REVISIONS MODIFICATIONS ANMERKUNGEN	DATE DATUM	ECN NO
<input type="checkbox"/> ADD. AJOUTER. ADDIEREN <input type="checkbox"/> REMOVE. SUPPRIMER. ENTFERNEN. <input type="checkbox"/> WAS. ETAIT. WAR.				
PART NAME GRATE SCRAPER ASSEMBLY				
DESIGNATION				
BENENNUNG				
FIRST USED ON MACHINE VERWENDDUNG		PAT / MOLD NO		
SCG				
NEXT REV ENDECKE		MODELE		
GROUP GRUPPE		MODELL NR		
DRAWN BY MESSING GEZEICHN		DATE DATUM	SCALE ECHELLE MASSSTAB	
CNK		14.12.09	0,500	
CHK BY VERIFIE GEPROBT		DATE DATUM	SHEET FEHLE BOGEN	OF DE VON
GJ		15.12.09	1	1
HOBART		C-00-739857		REV VORLAGE ANMERK
				c

D  
C  
B  
A

D  
C  
B  
A

4 3 2 1

4 3 2 1

4 3 2 1

4 3 2 1

8986EL-00-C

B RELEASED TO PRODUCTION 14.12.09 EU 8334

THIS DOCUMENT CONTAINS PROPRIETARY AND CONFIDENTIAL DATA OF HOBART CORPORATION OR ITS SUBSIDIARIES NO DISCLOSURE, REPRODUCTION OR USE OF ANY PART THEREOF MAY BE MADE WITHOUT WRITTEN PERMISSION OF HOBART.  
 CE DOCUMENT CONTIENT DES DONNEES CONFIDENTIELLES APPARTENANT A HOBART CORPORATION OU A SES FILIALES. AUCUNE DIVULGATION, REPRODUCTION OU UTILISATION DE TOUT OU PARTIE DE CE DOCUMENT NE PEUT ETRE FAITE SANS L'AUTORISATION ECRITE D'HOBART.  
 DAS URHEBERRECHT AN DIESER ZEICHNUNG VERBEIHT BEI DER HOBART CORPORATION ODER EINER IHRER TOCHTERGESSELLSCHAFTEN. JEDE NICHT VON UNS SCHRIFTLICH GENEHMIGTE BENUTZUNG, VERVIELFALTIGUNG, UBERLASSUNG AN DRITTE USW IST STRAFBAR UND MACHT SCHADENERSATZPFLICHTIG

00-739860 (x2) HANDLE - SCRAPPER  
 LWM-E-3-27 (x2) 8mm SINGLE COIL LOCKWASHER  
 SCM-E-14-15 (x2) M8x20 HEX HD SCREW

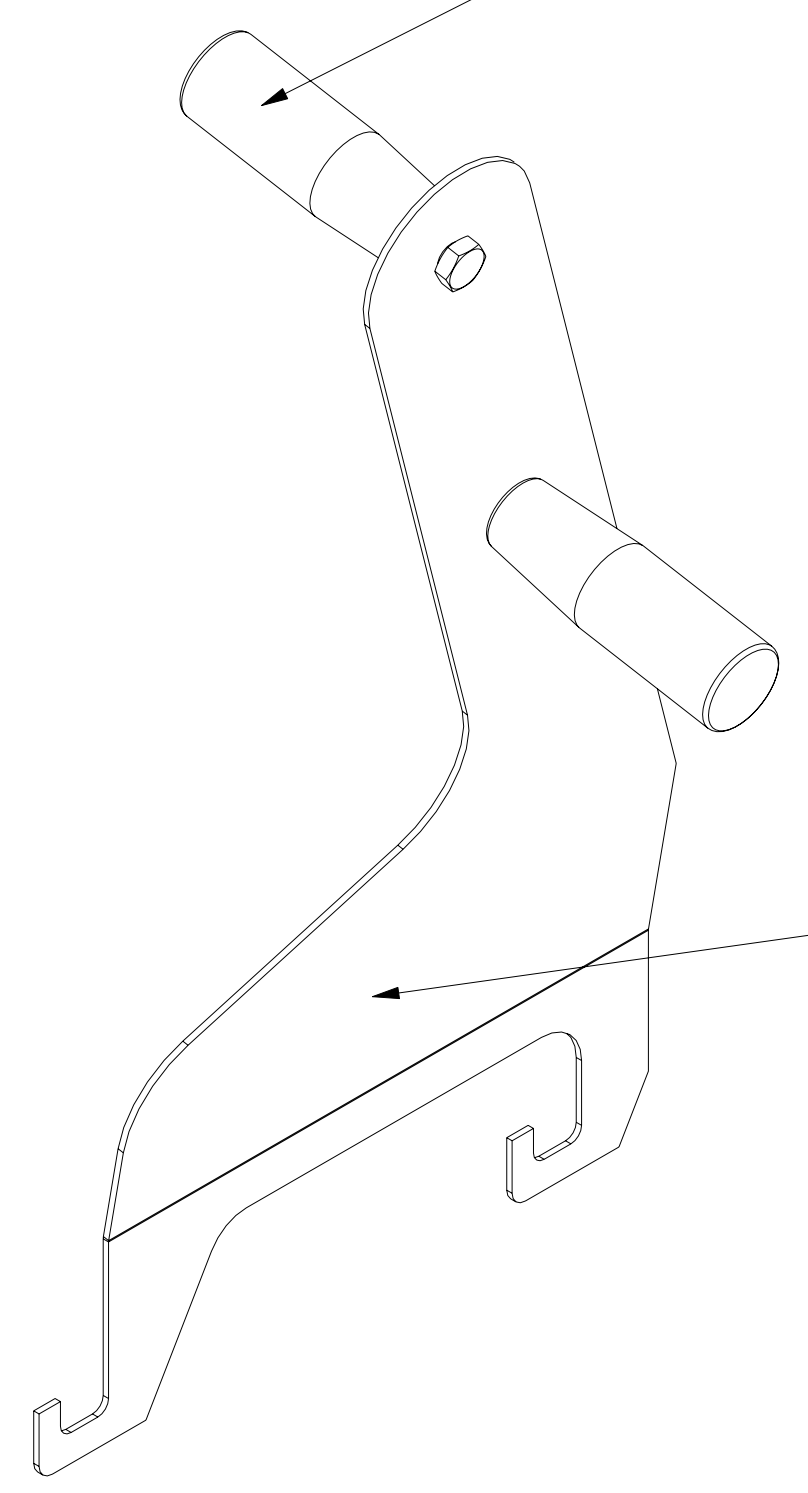

00-739806 GRATE LIFTING TOOL

REF : DCC UK CAD		MATERIAL	
TOLERANCES NOT SPECIFIED TOLERANCES NON SPECIFIEES NICHT TOLERIERTE MASSE		SEE NOTES	
REMOVE ALL BURRS AND SHARP EDGES REPORT ERRORS IMMEDIATELY		FINISH	
(EXCEPT HOLES) (EXCEPT LOS TROUS) ± mm (LOCHER AUSGESCHGLOSSEN)		DO NOT SCALE DRAWING STOCK SIZE :- STANDARD COMMERCIAL TOLERANCES APPLY	
HOLE TOLERANCES TOLERANCES DE TROUS LOCH-TOLERANZEN		ENLEVER TOUTES LES BAVURES ET LES ANGLES VIFS RAPPORTER LES ERREURS IMMEDIATEMENT	
RADI (R) RAYONS (R) RADIEN (R) 3-5 mm		NE PAS PRENDRE DES COTES L'ECHELLE	
ANGLES WINKEL ±1°		SUREPAISSEURS-APPLIQUER LES TOLERANCES STD. DU COMMERCE	
CHAMFERS (C) CHANFREIN (C) 0.5 x 40° 50° FASEN (C)		ALLE KANTEN ENTGRATEN	
		FEHLER SOFORT MELDEN	
		NICHT MASSTABILCH	
		ROHMATERIAL-NORM TOLERANZEN VERWENDBAR	

ZONE	LTD INDICE AND NO	REVISIONS MODIFICATIONS ÄNDERUNG	DATE DATE DATUM	ECH NO
ADD. AJOUTER. ADDIEREN		REMOVE. SUPPRIMER. ENTFERNEN.		WAS. ETAIT. WAR.
PART NAME GRATE LIFTING TOOL ASSEMBLY				
DESIGNATION				
BENENNUNG				
FIRST USED ON MACHINE VERWENDDUNG		PAT / MOLD NO		
SCG				
NEXT COPY ENDELLER		MODELE		
SHOPS REPLACE ERSETZEN		MODELL NR		
DATE DATE DATUM		SCALE ECHELLE MASSSTAB		0,500
CNK		14.12.09		1
GJ		15.12.09		1
HOBART		C-00-739858		B

8986EL-00-C

B RELEASED TO PRODUCTION 14.12.09 EU 8334

THIS DOCUMENT CONTAINS PROPRIETARY AND CONFIDENTIAL DATA OF HOBART CORPORATION OR ITS SUBSIDIARIES NO DISCLOSURE, REPRODUCTION OR USE OF ANY PART THEREOF MAY BE MADE WITHOUT WRITTEN PERMISSION OF HOBART.  
 CE DOCUMENT CONTIENT DES DONNEES CONFIDENTIELLES APPARTENANT A HOBART CORPORATION OU A SES FILIALES. AUCUNE DIVULGATION, REPRODUCTION OU UTILISATION DE TOUT OU PARTIE DE CE DOCUMENT NE PEUT ETRE FAITE SANS L'AUTORISATION ECRITE D'HOBART.  
 DAS URHEBERRECHT AN DIESER ZEICHNUNG VERBEIBT BEI DER HOBART CORPORATION ODER EINER IHRER TOCHTERGESSELLSCHAFTEN. JEDE NICHT VON UNS SCHRIFTLICH GENEHMIGTE BENUTZUNG, VERVIELFALTIGUNG, UBERLASSUNG AN DRITTE USW IST STRAFBAR UND MACHT SCHADENERSATZPFLICHTIG

00-739860 (x2) HANDLE - SCRAPPER  
 LWM-E-3-27 (x2) 8mm SINGLE COIL LOCKWASHER  
 SCM-E-14-15 (x2) M8x20 HEX HD SCREW

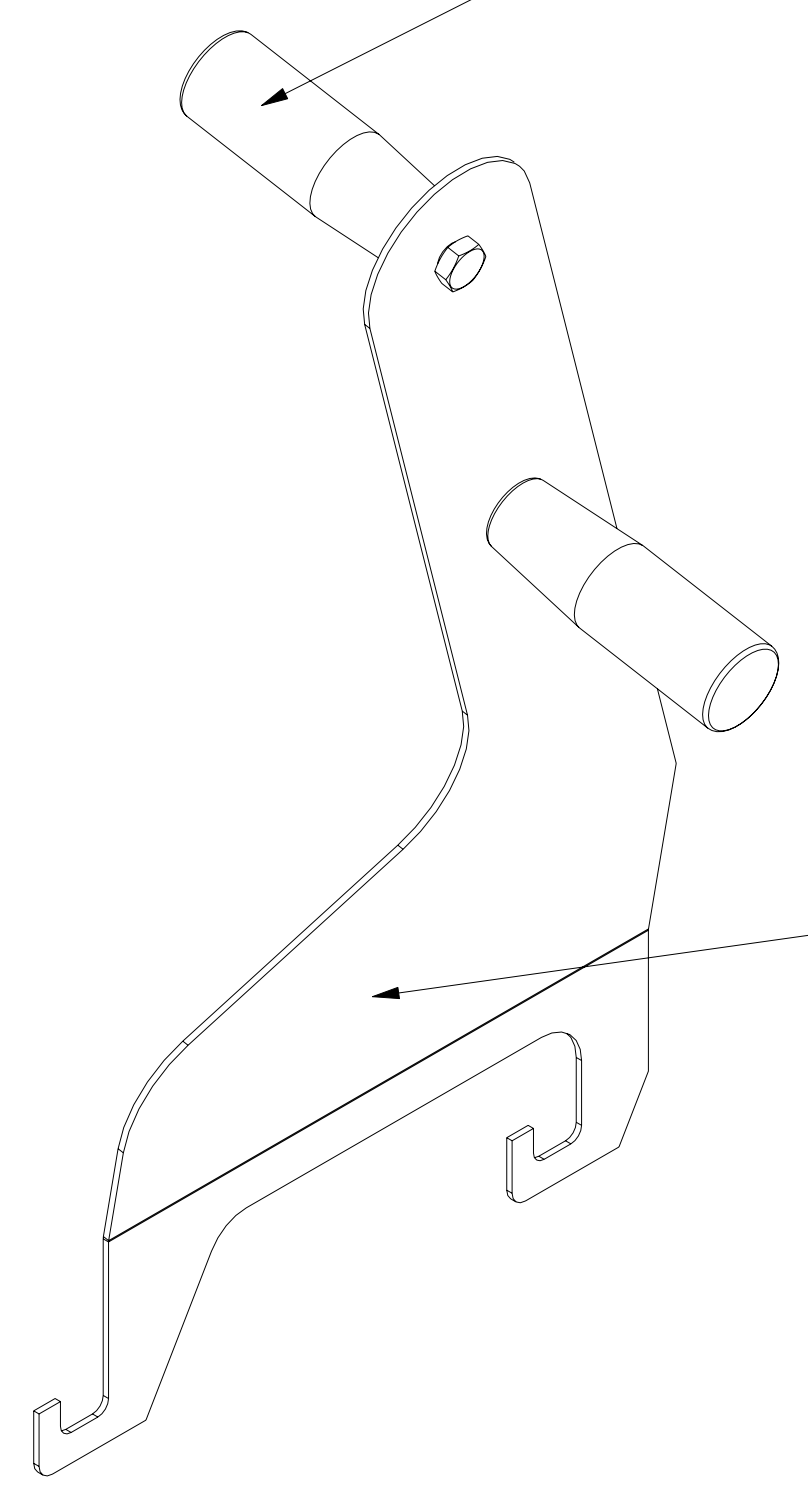

00-739806 GRATE LIFTING TOOL

REF : DCC UK CAD		MATERIAL	
TOLERANCES NOT SPECIFIED TOLERANCES NON SPECIFIEES NICHT TOLERIERTE MASSE		SEE NOTES	
REMOVE ALL BURRS AND SHARP EDGES REPORT ERRORS IMMEDIATELY		FINISH	
(EXCEPT HOLES) (EXCEPT LOS TROUS) ± mm (LOCHER AUSGESCHGLOSSEN)		DO NOT SCALE DRAWING STOCK SIZE :- STANDARD COMMERCIAL TOLERANCES APPLY	
HOLE TOLERANCES TOLERANCES DE TROUS LOCH-TOLERANZEN		ENLEVER TOUTES LES BAVURES ET LES ANGLES VIFS RAPPORTER LES ERREURS IMMEDIATEMENT	
RADI (R) RAYONS (R) RADIEN (R) 3-5 mm		NE PAS PRENDRE DES COTES L'ECHELLE	
ANGLES WINKEL ±1°		SUREPAISSEURS-APPLIQUER LES TOLERANCES STD. DU COMMERCE	
CHAMFERS (C) CHANFREIN (C) 0.5 x 40° 50° FASEN (C)		ALLE KANTEN ENTGRATEN	
		FEHLER SOFORT MELDEN	
		NICHT MASSTABLICH	
		ROHMATERIAL-NORM TOLERANZEN VERWENDBAR	

ZONE	LTD INDICE AND NO	REVISIONS MODIFICATIONS ÄNDERUNG	DATE DATE DATUM	ECH NO
ADD. AJOUTER. ADDIEREN		REMOVE. SUPPRIMER. ENTFERNEN.		WAS. ETAIT. WAR.
PART NAME GRATE LIFTING TOOL ASSEMBLY				
DESIGNATION				
BENENNUNG				
FIRST USED ON MACHINE VERWENDDUNG		PAT / MOLD NO		
SCG				
NEXT COPY ENDELLER		MODELE		
SHOPS REPLACE ERSETZT		MODELL NR		
DATE DATE DATUM		SCALE ECHELLE MASSSTAB		
CNK		14.12.09		0,500
GJ		15.12.09		1
DATE DATE DATUM		DATE DATE DATUM		DATE DATE DATUM
HOBART		C-00-739858		REV ÄNDER B



# BONNET

Hobart trained service technicians strategically located at the listed Hobart branches are prepared to give you fast, efficient and reliable service. Protect your investment by having a Hobart inspection contract, which assures the continued, efficient operation of your Hobart machines, spares and accessories.

Nos techniciens qualifiés de S.A.V., stratégiquement répartis dans les établissements Hobart, sont prêts à vous offrir un service rapide, efficace et fiable. Protégez votre investissement en optant pour un contrat d'inspection Hobart afin d'assurer la continuité et la qualité de fonctionnement de vos appareils, pièces de rechange et accessoires Hobart.

An den aufgeführten, strategisch günstig gelegenen Standorten stehen qualifizierte Hobart-Kundendienstfachleute bereit, um Ihnen schnellen, effizienten und zuverlässigen Service zu bieten. Bewahren Sie Ihre Investition durch einen Hobart-Wartungsvertrag, der Ihnen jederzeit störungsfreien Betrieb sowie Ersatzteile und Zubehör garantiert.

**For further details contact:-**

## **HOBART SERVICE UK**

**SALES : SERVICE : SPARES:  
0844 888 7777**

**Hobart UK  
Southgate Way  
Orton Southgate  
Peterborough, PE2 6GN  
Fax 01733 361 347  
www.hobartuk.com**

Continued product improvement is a Hobart Still policy, specifications may change without notice.

## **HOBART SERVICE GERMANY**

### **SERVICE-INFORMATIONEN UND -TELEFONNUMMERN.**

**Ausführliche Informationen erhalten Sie bei Ihrem Fachhändler, oder unter:**

**Service Tel. 01803 / 45 62 58 – [www.hobart.de](http://www.hobart.de) – [info@hobart.de](mailto:info@hobart.de) (innerhalb Deutschland)**

**HOBART behält sich das Recht vor, an allen Produkten Änderungen oder Verbesserungen ohne Ankündigungen vorzunehmen**

## **HOBART SERVICE FRANCE**

**Telephone : 0825021222**

**Hobart ayant une politique d'amélioration constante de ses produits, les spécifications peuvent changer sans préavis.**





## BCB Bonnet

# Char Broiler with piezo ignition.



**INSTALLATION**

**OPERATION**

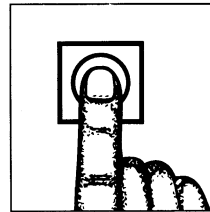
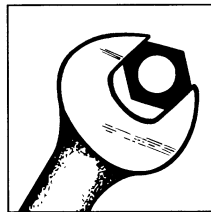

This appliance shall be installed in conformity with the current regulations and only used in a well-ventilated location. Consult these instructions before installing and using this appliance.



PLE200537 – K EU9412

**PLEASE KEEP THIS MANUAL IN A SAFE PLACE FOR FUTURE REFERENCE.**

## **CONTENTS.**

<b>DESCRIPTION</b>	<b>SECTION</b>	<b>PAGE</b>
<b>SAFETY AND GENERAL INFORMATION</b>		
Safety information	1	3
Safety guidelines	1.1	3
Warning symbols	1.2	4
Liability	1.3	5
Definitions	1.4	5
Environmental responsibility	1.5	5
Packing material	1.5.1	5
Disposal of your old appliance	1.5.2	5
Foreword	2	5
General information	3	6
BCB Bonnet Char Broiler component identification.	Photograph 1.	6
Features and benefits	3.1	7
Safety instructions	4	7
Never	4.1	8
Always	4.2	8
<b>INFORMATION FOR OPERATORS AND USERS</b>		
Operating the BCB Bonnet Char Broiler	5	9
Lighting and setting up instructions	5.1	9
Using the BCB Bonnet Char Broiler	5.2	11
Cooking ideas	5.3	11
Reversing the grates	5.4	12
Using the grate removal tool	5.5	13
At the end of the day.	5.6	14
Cleaning	6	14
Cleaning the grates	6.1	14
Cleaning the radiants	6.2	15
Cleaning external surfaces	6.3	15
Cleaning the heat reflector cassette	6.4	15
Deep cleaning the appliance	6.5	16
<b>INFORMATION FOR INSTALLATION AND COMMISSIONING.</b>		
Design and construction data	7	17
Technical information. Part 1.	Table 1	17
Technical information. Part 2.	Table 2	19
Burner and pilot orifice dimensions.	Table 3.	20
Gas categories and pressures.	Table 4.	20
Gas consumption and energy usage	Table 5.	21
Installation dimensions.	Figure 1.	23
Installing the BCB Bonnet Char Broiler	8	24
Unpacking and handling	8.1	24
Location	8.2	24
General installation guidelines	8.3	24
Mounting of the appliance	8.4	25
Gas pipe work	8.5	25
Ventilation	8.6	25
Gas installation	8.7	26
Fitting the gas regulator	8.8	27

<b>DESCRIPTION</b>	<b>SECTION</b>	<b>PAGE</b>
Electrical earth bonding connection	8.9	27
<b>INFORMATION FOR MAINTENANCE AND REGULAR SERVICING</b>		
Commissioning instructions	9	27
Check the manifold inlet gas pressure	9.1	28
Operator training	9.2	28
Maintenance	10	28
Gas control system component identification.	Photograph 23.	29
Adjusting the pilot burner flame	10.1	29
Replacing the pilot burner	10.2	30
Replacing the thermocouple	10.3	32
Replacing the main burner	10.4	33
Replacing the main burner jet	10.5	34
Replacing the gas control valve	10.6	34
Adjusting the main burner low flame	10.7	35
Conversion from natural gas to LPG	10.8	36
Fault finding	11	36
Fault summary	11.1, Table 7	36
Service maintenance	12	37
Service interval	Table 8	37
Spare parts	13, Table 9	37
Service contacts	14	39

## **1.0 SAFETY INFORMATION.**

The procedures and precautions contained in this manual apply to BCB Bonnet Char Broiler only when used in the prescribed manner.

If the BCB Char Broiler is used other than in the recommended manner, the operator will be responsible for his/her own safety and for the safety of the other persons who may be involved.

The information in this manual has been prepared to assist the operator to understand, maintain, and operate the Char Broiler. In order to prevent accidents, read, understand and follow all the precautions and warnings contained in this manual before installation or operating for the first time. This manual must be studied to obtain a clear understanding of the BCB Bonnet Char Broiler and its capabilities.

Hot surfaces and gas are dangerous and may cause injury if sufficient precautions are not taken prior to operating or servicing the BCB Bonnet Char Broiler.

The BCB Bonnet Char Broiler must only be serviced by **Qualified Service Personnel**. Ensure the gas supply has been isolated and all hot surfaces are allowed to cool to an acceptable temperature before attempting to service the unit. In certain fault finding situations it may be necessary to operate the machine whilst still hot; in which case extreme caution must be used.

These instructions are only valid for the countries listed in table 4 section 7.

This appliance shall be installed by a competent, trained and qualified person in conformity with the current local gas regulations. The appliance must only be used in a well-ventilated location. Consult the instructions before installing and using this appliance.

The BCB Bonnet Char Broiler is only intended for professional use by suitably qualified personnel.

### **1.1 SAFETY GUIDELINES.**

Ensure sufficient precautions are observed during manually handling of the BCB Bonnet Char Broiler particularly when moving into position on installation. Reference must be made to manual handling regulations. The BCB Bonnet Char Broiler weights are given in table 2, section 7. Refer to section 4 for installation and operating safety instructions.

- Do not hose or pressure clean this appliance. It is vital to adhere to the cleaning instructions detailed in this manual.
- Do not remove any covers or loosen any fittings whilst the appliance is operating.
- Ensure this manual is kept in an easily accessible place near the BCB Bonnet Char Broiler for future reference.
- All operators must be trained in the safe use and operation of the appliance.

- This appliance is not intended for use by persons if their physical, sensory or mental capabilities prevent them from using it safely.
- This BCB Bonnet Char Broiler is not intended for use by children.
- Ensure the gas supply has been isolated before attempting to service or move the appliance.
- The appliance must be disconnected from the gas supply before withdrawing.
- Instructions must be placed in a prominent position within the kitchen that will advise operators of this appliance of the procedure in the event a gas leak is detected by smell or other means.
- Hot surfaces and gas are potentially hazardous and may cause injury if sufficient precautions are not taken prior to operating or servicing the machine.
- Always have your gas appliance regularly serviced; at least once a year, depending on frequency of use (refer to table 8, section 12). For information on service contracts please contact your local Hobart sales office.
- Prior to installation and connection the appliance, check the gas type and rating on the data plate corresponds with the gas supply.
- The area around the BCB Bonnet Char Broiler must always be kept free and clear of combustibles such as solvents, cleaning fluids, mops, rags, brooms, etc.
- Do not obstruct any vents or openings on the appliance.
- The appliance must be installed with sufficient ventilation to prevent the occurrence of unacceptable concentrations of substances harmful to health in the room in which they are installed.
- When the char broiler is used with LPG it is important there is adequate ventilation inside and around the gas cylinder compartment at all times, i.e. ensure there is a permanent supply of fresh air and no accumulation of unburnt gases.

## 1.2 **WARNING SYMBOLS.**

To identify the safety messages in this manual, the following symbol has been used



The "Warning" symbol is found primarily where the corresponding information is important for the safe use of the machinery.

### **1.3 LIABILITY.**

Installations and repairs which are not carried out by **Authorised technicians** or the use of other than original spare parts, and any **technical alterations** to the appliance, **may affect the warranty set out in the standard conditions of sale.**

### **1.4 DEFINITIONS.**

**Qualified operators.** The BCB Bonnet Char Broiler is only intended for professional use by qualified operators. Qualified operators are those personnel who have received training in the operation of the appliance from a suitably qualified person and have carefully read the information in this manual and are familiar with the equipment's function or had previous experience with the operation of this similar Char Broilers.

**Qualified installation personnel.** Any 'work' performed within the UK on the appliance including installation that is within the scope of the Gas Safety (Installation and Use) Regulations shall be carried out by a business that is Gas Safe approved (Council for Registered Gas Installers) and approved by the Health and Safety Executive (HSE). For countries outside the UK qualified installation personnel must be experienced and familiar with precautions required and have complied with all requirements of state and local authorities having jurisdiction. In the EU installation must comply with national or local requirements of the country of destination of the appliance.

**Qualified Service Personnel.** Those who are competent, trained and approved by Hobart UK. All service personnel are required to be equipped with a complete set of manuals and original service parts.

### **1.5 ENVIRONMENTAL RESPONSIBILITY.**

#### **1.5.1 PACKING MATERIAL.**

The pallet and protective polyethylene packing film have been selected from materials that are environmentally friendly for disposal or can normally be recycled. Instead of throwing them away, please ensure they are recycled. This packaging shall be disposed of in accordance with the regulations in force.



#### **1.5.2 DISPOSAL OF YOUR OLD APPLIANCE.**

Old appliances contain materials that can be recycled. Please contact your local waste collection centre; scrap merchant or local Hobart office about potential recycling schemes.

### **2.0 FOREWORD.**

Hobart reserves the right to alter the design of their products without prior notice. Whilst every effort is made to ensure this publication reflects the latest design, the Company cannot guarantee full compliance.

Take pride in your **BCB Char Broiler** - keep it clean and in good mechanical condition. Refer to the cleaning and maintenance sections in this manual.

### 3.0 GENERAL INFORMATION

The information and instructions contained in this manual may not cover all details or variations in the equipment, nor provide for every eventuality to arise with installation, operation, or maintenance. If additional information is required please contact your local Hobart office.

The BCB Char Broiler is designed to operate on natural gas (I<sub>2H</sub>, I<sub>2E</sub> and I<sub>2E+</sub>) propane (I<sub>3P</sub>) and butane (I<sub>3B</sub>). The appliance is for commercial use and is intended for the cooking of meat, seafood, pita bread and stockpot heating. The BCB reversible grates ensure 'zoned' cooking temperatures. The specially designed cast iron grates have an angled grease trough to ensure excess food waste and fat to run off to enable the equipment to operate at its optimum performance. The grates are removable to allow the radiants to be quickly and easily cleaned. The broiling grates are reversible so they can be either flat or angled depending on the food product being cooked. A removable stainless steel heat reflector cassette positioned under the burners reflects heat up to the radiants and ensures the drip tray area remains at a relatively low temperature. The finned heat radiants situated under the grates control cross draughts within the BCB Char Broiler to maintain a constant cooking temperature for maximum efficiency and optimum cooking results. The piezo ignition system enables the appliance to be lit without removing the grates and radiants. The piezo igniter lights the pilot burner. One piezo igniter is used for two pilot burners. The appliance has provision for secondary lighting, using a wooden taper or long nose gas igniter, if the need arises.

The BCB Char Broiler is supplied with adjustable stainless steel legs for bench mounting



**BCB BONNET CHAR BROILER COMPONENT IDENTIFICATION. PHOTOGRAPH 1.**

### **3.1 FEATURES AND BENEFITS.**

- Robust and strong design.
- Stainless steel construction to reduce corrosion.
- Integral splash back
- Reversible grates flat or angled.
- 4 grate slope options (0 to 8°)
- Slanted cast iron grates with fat gully.
- High power burners each rated at 3.7 kW for natural gas, 3.6 kW butane and 3.1 kW for propane.
- Cast iron radiants to provide an even cooking temperature over the entire grate.
- Straight cast iron grates available.
- Removable heat reflector cassette to ensure improved cooking efficiency and create a lower temperature zone in the drip tray area.
- Low drawer surface temperature (80°C)
- Easy to withdraw heat reflector cassette for improved clean ability.
- Individually controlled main burners.
- Flame failure protection.
- Piezo ignition of pilot burners.
- Good visibility of the pilot burners
- Easy secondary ignition of the pilot burners.
- Effective guard to protect the pilot burner from fat and food debris.
- Removable internal heat deflector panel to ease access to the pilot burners and gas valves during service.
- Twin slope fat gully (BCB1200, BCB1500 & BCB1800 models)
- No gas regulator required for 20 mB natural gas supply
- Full or half flame burner control.
- Finned heat radiants to control cross draughts within the Char Broiler and maintain a constant cooking temperature.
- Removable grates and radiants to ensure daily cleaning in quick and easy.
- Easy clean stainless steel exterior surfaces.
- Stainless steel drip trays to collect fat and food waste.
- Grate removal tool supplied as standard.
- Cleaning scoop supplied as standard.
- Effective grate cleaning tool supplied as standard
- Adjustable height legs (100 to 125mm)
- Insulated rear panel.
- Optional steel fry plate for fish, eggs, bacon etc.
- Mobile or static stand options available.

### **4.0 SAFETY INSTRUCTIONS.**



**ONLY A FULLY TRAINED AND COMPETENT PERSON MUST USE THE BCB BONNET CHAR BROILER GRILL.**

The following instructions must be observed when using the appliance.

Note: The BCB Bonnet Char Broiler must only be used for the purpose it was design and inline with the operating instructions.



## 4.1 **NEVER**

- Allow children, infirm persons or unqualified personnel to operate the grill.
- Operate the Char Broiler if a fault develops or is unsafe.
- Wear loose clothing.
- Wear clothing such as silks, polyester, etc that are highly flammable when using this appliance.
- Use bleach, hypochlorite or chlorine compounds to clean the Char Broiler internally or externally.
- Use excessive force when operating which could affect the stability of the appliance.
- Operate the Char Broiler if parts are disassembled.
- Use the appliance in an unsafe condition.
- Clean the Char Broiler with scouring powder or a scouring pad.
- Dry tea towels and cloths on the appliance.
- Cover the entire cooking area with stock pots, pans or trays. A maximum of 80% of the surface is acceptable provided the grate ventilation slots are clear.
- Obstruct openings or heat vents.
- Line the drip tray with aluminium foil.
- Tamper or change any sealed devices on the appliance.
- Remove the main burner.
- Use wax tapers to ignite the pilot light.
- Allow debris to accumulate on the grates or radiants.
- Wire a faulty control knob to make it operate. This is over-riding a safety feature and is highly dangerous and illegal.
- Spray oil or grease directly onto the cooking area.
- Spray water directly onto the thermocouple or pilot burner.
- Override the gas controls in any way.
- Fill the drip trays with sand.
- Ignite the appliance using a 'home made' paper taper.
- Use a waxed taper for lighting the gas pilot burner.
- Cover the complete surface of the cooking area.

## 4.2 **ALWAYS**

- Ensure the Char Broiler is correctly assembled before lighting.
- Use the appliance in a well-lit area.
- Use the Char Broiler as intended and inline with the operating instructions.
- Be aware of hot surfaces on the appliance.
- Use appropriate personal protective equipment (PPE).
- Take care when using the gas control knobs. They are the most delicate part of the appliance and will break if excessive force is used.
- Use the lifting tool when removing or adjusting the grates.
- Clean the appliance before each use or day
- Clean the grates using the scraping tool during the day.
- Regularly clean the fat gully and drain pipes situated at the front of the appliance during the day.

## 5.0 OPERATING THE BCB BONNET CHAR BROILER.

### 5.1 LIGHTING AND SETTING UP INSTRUCTIONS.

It is not necessary to remove the grates and radiants when using the piezo ignition system. However in certain instances the grates and radiants may be removed. If the piezo igniter fails to light the appliance, the front panel has been designed with provision for secondary lighting using a wooded taper or long nose gas igniter.



**WARNING!** Before attempting to remove the grate and radiants ensure they are at an acceptable temperature to touch and handle. This will normally take approximately 3 hours after turning off the main burner.



**GRATES AND RADIANTS.  
PHOTOGRAPH 2.**



**PILOT BURNER 'ON'  
POSITION. PHOTOGRAPH 3.**

1. Ensure the extraction system and gas supplies to the BCB are turned 'on'.
2. Push in and turn the control knob approximately 30 degrees anti-clockwise to the ignition point indicated by the star (\*) symbol as shown in photograph 3.
3. Push and hold the control knob 'in' for approximately 5 seconds to release gas from the pilot burner jet and then press the piezo igniter. Normally only 2 or 3 'clicks' are required to ignite each pilot burner. Hold the control knob in for 10 to 15 seconds before releasing. This allows the flame failure control system to heat up to its normal operating temperature. If the pilot burner does not remain illuminated wait three minutes and try again. The ignition position (\*) allows the pilot light to burn continuously. In a cold kitchen the heat up time may be longer, up to 20 seconds.

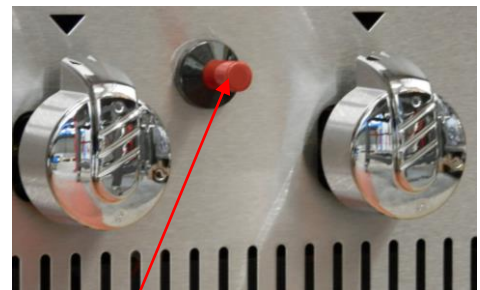

Piezo igniter positioned between 2 gas valves.

**PIEZO IGNITER POSITION  
BETWEEN GAS VALVES.  
PHOTOGRAPH 4.**



**REPLACING THE RADIANTS.  
PHOTOGRAPH 5.**

4. If the grates and radiants have been removed replace them. Do not attempt to fit the radiants and grates if the main burner is ignited. Place the radiant on the backrest first and then lower the front (refer to photograph 5).

5. To ignite the main burner, turn the knob to the 'flame' position. Allow approximately 45 minutes for the appliance to heat up to temperature before starting to cook. During quieter periods either turn off some of the burners or reduce to the half flame position (refer to photograph 6).



**MAIN BURNER 'ON'  
LOW FLAME POSITION.  
PHOTOGRAPH 6.**



**MAIN BURNER 'ON'  
FULL FLAME POSITION.  
PHOTOGRAPH 7.**



**PILOT BURNER  
'ON' POSITION.  
PHOTOGRAPH 8.**

6. The drip trays should be emptied at the end of the day. Wear suitable personnel protective equipment since the trays will be hot.

7. To extinguish the main burner and leave the pilot flame burning turn the control knob clockwise to the star (\*) position shown in photograph 8.

8. To turn off the BCB Char Broiler main burner and pilot flame, rotate the control knob to the 'OFF' position indicated by the dot and groove moulded in the control knob.



**'OFF' POSITION.  
PHOTOGRAPH 9.**

## 5.2 USING THE BCB BONNET CHAR BROILER.

The following notes provide general guidance on the operation of the BCB Char Broiler.

- It is important the appliance is maintained in a clean and tidy condition especially in the cooking zone where fat, oils and carbon deposits can build up. The char broiler must be clean before it is lit in order to avoid the risk of fire from the oils that have accumulated during previous cooking period.
- When the BCB Char Broiler is fully loaded with food product adjust the gas valves to a lower setting to prevent overheating causing the food to char.
- During daily use the grates must be cleaned with the scraping tool and cleaning scoop. Do not allow debris to accumulate on the grates.
- Adjust the flame to the low setting or pilot burner during slack periods to conserve energy.

## 5.3 COOKING IDEAS.

The following gives some cooking suggestions from your BCB Char Broiler. The appliance is very versatile and can be used to cook meat, vegetables, fruit, fish and much more, quickly and healthily.



**PHOTOGRAPH 10.**

### **Peppers, tomatoes and courgettes.**

Place tomato halves-skin side down having seasoned and brushed lightly with oil. Grill over medium heat until lightly charred on the outside but still firm, 3 minutes per side.

Place pepper halves-skin side down after seasoning and brushing with oil. Grill over medium heat until branded and golden or until tender, turning occasionally.



**PHOTOGRAPH 11.**

### **Fish steaks.**

Season the fish fillets with a shake or marinade of your choice. Grill the fillets, over medium heat until you can lift them off the grate without sticking, it will only take a minute or so. Turn the fish and finish cooking the other side.

### **Steaks and Chops.**

Steaks, meat and chops can be marinated, seasoned and

oiled to your liking; food can be turned at right angles during cooking to achieve the diamond pattern shown in the picture. Cooking steak fast at high temperatures assures moisture, vitamin, mineral and flavour retention.



**PHOTOGRAPH 12.**

## 5.4 REVERSING THE GRATES.

The slope of the grates can be altered to suit the type of food being cooked. The shape of the casting at the far end allows the grates to be positioned either way up, with a slope to the front trough of the appliance or flat, as shown below. The angled position is used for the cooking of meat and fish products where excess oil or fat can run away from the cooking area into the trough situated at the front of the appliance. There are 5 grate positions.



**WARNING!** Before attempting to alter the grate positions ensure they are at an acceptable temperature to touch and handle. This will normally take approximately 3 hours after turning off the main burner.

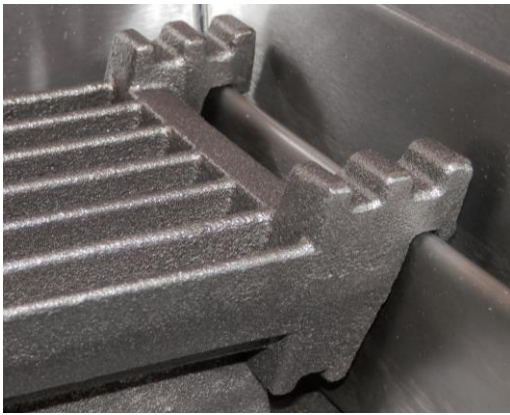

**POSITION 1. FLAT GRATE.**

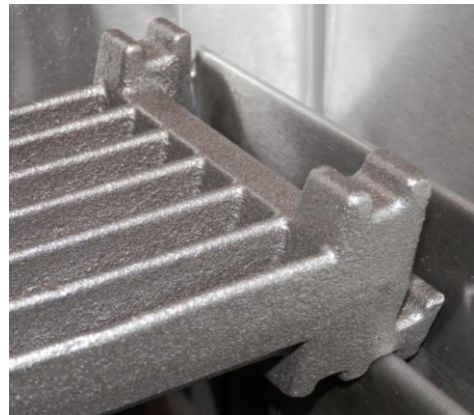

**POSITION 2. 4° ANGLED GRATE.**

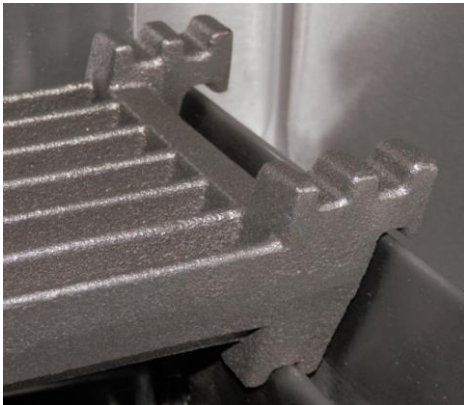

**POSITION 3. 4° ANGLED GRATE.**

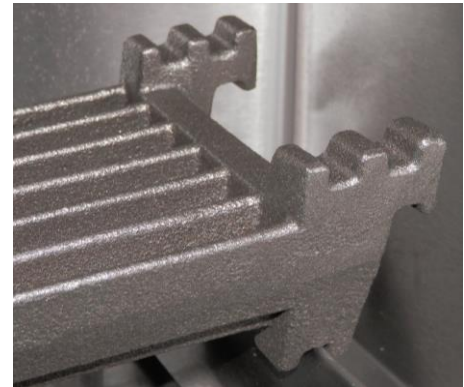

**POSITION 4. 8° ANGLED GRATE.**

**GRATES SHOWN FLAT AND SLOPING. PHOTOGRAPH 13.**

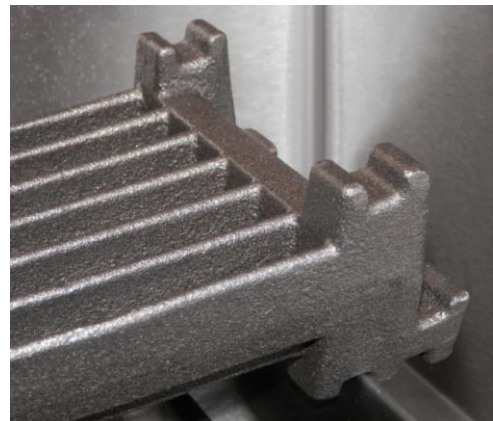

**POSITION 5. 8° ANGLED GRATE.**

## 5.5 USING THE GRATE REMOVAL TOOL.

The following sequence describes the procedure to lift and replace a grate.



**GRATE LIFTING TOOL.  
PHOTOGRAPH 14.**



**LOCATING THE LIFTING TOOL ON THE  
GRATE RIBS. PHOTOGRAPH 15.**



**USING TWO HANDS LIFT THE GRATE  
FROM THE BCB. PHOTOGRAPH 16.**



**GRATE REMOVED FROM THE CHAR  
BROILER. PHOTOGRAPH 17.**

1. The grate lifting tool can be used to remove the grates from the appliance.
2. Locate the tool in the centre of the grate so the hooked part locates on the horizontal ribs running across the grate as shown in picture 2 above.
3. Using the two handles lift the grate from the appliance. If the grate is hot ensure it is placed on a heat resistant surface.
4. Replacement is the reverse of the above procedure.

**Caution! Wear suitable protective clothing when handling hot grates.**

## 5.6 AT THE END OF THE DAY.

Towards the end of the day when demand on the appliance is less, gradually turn off some of the burners or reduce to the low flame position.

At the end of service turn all the grates over and put the burners on the full flame position for 20 minutes as described below. This will carbonise all fat deposits.

1. Turn the gas control to the pilot burner position and leave the appliance for 30 minutes to cool.
2. Using heat proof gloves and the lifting tool remove the right hand grate and place on a heat resistant surface in a safe manner.
3. Flip over the remaining grates and replace the original grate. Turn the appliance onto the full flame setting and leave for 20 minutes.
4. Turn off all the burners and isolate the gas supply.
5. Leave the grates to cool overnight. Next day flip over and wearing suitable PPE clean the grates using the scraping tool and cleaning scoop supplied with the appliance.



## 6.0 CLEANING.

**HEAVILY SOILED  
GRATE. PHOTOGRAPH 17**



DO NOT HOSE OR PRESSURE CLEAN THIS BCB CHAR BROILER. INDIVIDUAL PARTS MAY BE PRESSURE CLEANED. REFER TO THE FOLLOWING SECTION.

DO NOT USE ANY ABRASIVE CLEANERS

REFER TO THE RELEVANT COSHH DATA SHEETS PRIOR TO USING ANY CLEANING PRODUCTS.

WEAR APPROPRIATE PERSONAL PROTECTIVE EQUIPMENT (PPE).

To ensure correct operation of the gas burners it is important that the appliance is maintained in a clean condition. The gap between the ribs on each grate must be kept clean other wise the Char Broiler is likely to overheat. Do NOT allow the grates to get into the condition shown in photograph 17. This is unhygienic and can damage the appliance by causing overheating.

Prior to cleaning the appliance extinguish the main and pilot burner flames, isolate the gas supply using the locally fitted isolating valve and ensure the appliance is at an acceptable temperature to handle prior to cleaning.

Regularly clean the fat gully and drain pipes situated at the front of the appliance.

## 6.1 CLEANING THE GRATES.



WARNING! Before attempting to remove the grates ensure they are at an acceptable temperature to touch. This will normally take approximately 3 hours after using with the main burner.

1. Using the tool provided scrape the grates. Scrape the grease trough in the grates so the grease flow is uninhibited into the gutter and drip tray. This will reduce the risk of flare-up. Use the grate scraping tool supplied with the appliance. Do not

allow the grate to become heavily soiled as shown in photograph 17. This is very unhygienic and affects the performance of the Char Broiler.

2. After use, the grates should be turned over and the burners then put on the full flame position to burn off excessive fat and carbon. When the grates have cooled off, clean thoroughly with the grate scraper. Do not use water on the grates or soak over night since this will cause rusting.
3. The grates may be immersed in a strong commercial non-toxic cleaning solution over night. In the morning flush with hot water and steam clean to remove any debris.
4. If the grates have been deep cleaned using water or a caustic solution it is advisable to lightly coat with cooking oil to prevent corrosion. This will also help to season the grates.
5. Scrape clean the splash back gulley and front fat gulley using the cleaning scoop supplied with the appliance. Wash all areas thoroughly with a hot detergent solution.
6. Clean down the surrounding areas and extraction canopy with a hot detergent solution.
7. Remove the drip trays and empty at the end of the day. Wear suitable personnel protective equipment since the trays may be hot.

## **6.2 CLEANING THE RADIANTS.**

Occasionally the cast iron radiant situated under the grates may require cleaning.



**WARNING!** Before attempting to remove the grates and radiants ensure they are at an acceptable temperature to touch. This will normally take approximately 3 hours after using with the main burner.

1. The radiants may be cleaned thoroughly using a pallet knife or by immersing in a strong commercial non-toxic cleaning solution over night. In the morning flush with hot water and steam clean to remove any debris.

## **6.3 CLEANING THE EXTERNAL SURFACES.**

When the appliance is cool, the gas control knobs and stainless steel surfaces may be cleaned with a mild soap and hot water solution applied with a damp cloth. Rinse the surface with clean water and dry with a soft cloth. Do not use an abrasive or strong liquid cleaner on the stainless surface since they may damage the finish.

### **CAUTION ABOUT USING "SPRAY-ON" CLEANERS**

Be careful when using spray cleaners. Read the safety data sheet prior to use and follow the instruction label on the container. Wear appropriate protective clothing. Some cleaners may contain caustics.

## **6.4 CLEANING THE HEAT REFLECTOR CASSETTE.**

The heat reflector cassette/s is located beneath the main burners and reflects heat back up to the cooking surface and prevents the drip trays becoming excessively hot. The heat deflectors are removable for cleaning as shown in photographs 18.



Occasionally the heat deflectors may need to be removed for cleaning with a scraper. The baffles are removed as follows.

**WARNING!** Before attempting to remove the drip trays and heat deflectors ensure they are at an acceptable temperature to touch. If necessary wear suitable protective clothing.



**HEAT REFLECTOR CASSETTE AND DRIP TRAY. PHOTOGRAPH 18.**

1. Remove the drip tray taking care if it is full of hot fat or water.
2. Dispose of the fat or water in a suitable waste container.
3. Place the drip tray on a flat surface.
4. Remove the heat reflector cassette and clean with a scraper and hot detergent solution.
5. Clean drip tray with a scraper and hot detergent solution.
6. Replace the heat reflector cassette and drip tray to the appliance.

## **6.5 DEEP CLEANING THE APPLIANCE.**

Twice a week deep clean the appliance. This procedure will take approximately 1 to 1 ½ hours.

1. Clean the grates as described in section 6.1.
2. Ensure the drip trays are in position to collect food debris, carbon, etc.
3. Scrape all cast iron radiants clean while in situ. Remove and then set aside.
4. Remove the pilot burner cover by lifting up and out as shown below. If necessary slacken the mounting screws with a posi screw driver. Clean the cover with a scraper and hot detergent solution.
5. Replace on the mounting screws.

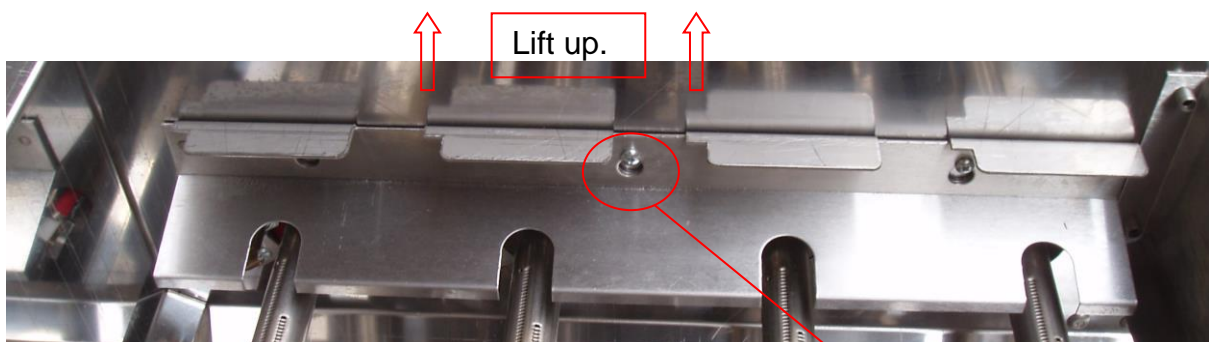

**PHOTOGRAPH 19. RADIANT SUPPORT/ PILOT BURNER COVER.**

Keyhole location slot.

6. If necessary carefully clean the flame outlet holes on each burner using a wire brush. This will prevent obstruction of the flame and allow good combustion.  
**Do not remove the burners.**
7. Scrape any food and carbon deposits from the frame of the appliance and allow to collect into the drip trays.
8. Ensure the drain pipes situated at either end of the front gully are clear of fat, food debris and carbon deposits from the appliance.
9. Remove the drip trays. Scrape all debris into a suitable waste bin. Wash the drip tray with a hot detergent solution.
10. Remove the heat reflector cassettes and scrape any debris and carbon deposits into a suitable waste bin.
11. Replace the heat reflector cassettes and drip tray. The Char Broiler is now ready for use.

## **7.0 DESIGN AND CONSTRUCTION DATA.**

The data listed in table 1 applies to all of the natural gas and LPG versions of the BCB Bonnet Char Broiler.

**TABLE 1. TECHNICAL INFORMATION, PART 1.**

Parameter	Units	Model		
		#BCBXXXX-1	#BCBXXXX-2	#BCBXXXX-7
Model code		Natural (G20)	Propane (G31)	Butane (G30)
Type of gas		Natural (G20)	Propane (G31)	Butane (G30)
Appliance type		A <sub>1</sub> (appliance not fitted with extract fan)	A <sub>1</sub> (appliance not fitted with extract fan)	A <sub>1</sub> (appliance not fitted with extract fan)
Appliance category		II <sub>2</sub> H <sub>3</sub> P	II <sub>2</sub> H <sub>3</sub> P	II <sub>2</sub> H <sub>3</sub> P
Nominal heat input per main burner (full flame)	kW (Btu/hour)	3.7 (12630)	3.1 (10580)	3.6 (12290)
Nominal heat input per main burner (low flame adjustable)	kW (Btu/hour)	1.6 (5460)	2.0 (6830)	2.1 (7170)
Nominal heat input per pilot burner	kW (Btu/hour)	0.2 (680)	0.2 (680)	0.2 (680)
Gas supply pressure (nominal)	m bar (inches water gauge)	20 (8)	37 (14.8)	29 (11.6)
Gas operating pressure (nominal); pressure at the appliance manifold.	m bar (inches water gauge)	20 (8)	25 (10.0)	20 (8)
Gas operating pressure (minimum); pressure at the appliance manifold.	m bar (inches water gauge)	17 (6.8)	24 (9.6)	17 (6.8)
Gas operating pressure (maximum); pressure at the appliance manifold.	m bar (inches water gauge)	23 (9.2)	26 (10.4)	23 (9.2)
Pressure tap nozzle size	mm (inch)	9.0 (0.354)	9.0 (0.354)	9.0 (0.354)
Minimum gas supply pipe internal diameter	mm (inch)	22 (7/8)	22 (7/8)	22 (7/8)

Parameter	Units	Model		
		#BCBXXCE-1	#BCBXXCE-2	#BCBXXCE-7
Burner orifice diameter (no adjustment)	mm	1.40	1.0	1.0
Burner orifice identification		140	100	100
Pilot orifice diameter	mm	0.41	0.25	0.25
Pilot orifice identification		1.6N	1.0P	1.0P
Thermocouple hold on time (nominal)	Seconds	15	15	15
Flame failure time (nominal)	Seconds	45	45	45
Recommended hood air flow velocity	m/s	0.4	0.4	0.4
Typical temperature above room ambient, at a height 1 metre above appliance cooking surface with extraction fan/hood system	°C	25	25	25
Typical temperature above room ambient, at a height 1 metre above appliance cooking surface without extraction fan/hood system	°C	40	40	40
<b>Minimum clearance dimensions</b>				
Combustible material, rear, above grid level	mm (inch)	305 (12)	305 (12)	305 (12)
Combustible material, rear, below grid level	mm (inch)	75 (3)	76 (3)	76 (3)
Combustible, material sides, above grid level	mm (inch)	225 (9)	225 (9)	225 (9)
Combustible, material sides, below grid level	mm (inch)	75 (3)	75 (3)	75 (3)
Combustible, material below	mm (inch)	100 (4)	100 (4)	100 (4)
Non-combustible, material below	mm (inch)	0 (0)	0 (0)	0 (0)
Non-combustible material, rear, above and below grid level	mm (inch)	75 (3)	75 (3)	75 (3)
Non-combustible material, sides, above and below grid level	mm (inch)	0 (0)	0 (0)	0 (0)
Adjustable leg thread size		3/8" UNC	3/8" UNC	3/8" UNC
Gas connection (to BS2779)	BSP	G3/4A (3/4" parallel male thread).	G3/4A (3/4" parallel male thread).	G3/4A (3/4" parallel male thread).
Initial heat up time on maximum burner setting	Minutes	30	30	30
Time for grates/radiants to cool to a safe handling temperature.	Hours	3	3	3
Grate (6 rib) weight each	kg	6.0	6.0	6.0
Grate (7 rib) weight each	kg	7.4	7.4	7.4
Radiant weight each	kg	4.1	4.1	4.1

Parameter	Units	Model		
		#BCBXXCE-1	#BCBXXCE-2	#BCBXXCE-7
Noise level	dB (A)	##less than 60	##less than 60	##less than 60
Storage conditions. Temperature and humidity.	°C, % RH	+5 to +55, 85	+5 to +55, 85	

# Refer to table 2 for specific model data. ## In accordance with EN-ISO 11202.

**TABLE 2. TECHNICAL INFORMATION, PART 2.**

Parameter	Units	BCB600	BCB900	BCB1200	BCB1500	BCB1800
Net weight	kg	91	128	160	199	241
External dimensions	W x D x H mm	643 x 820 x 528	914 x 820 x 528	1185 x 820 x 528	1535 x 820 x 528	1844 x 820 x 528
Shipping weight	kg	109	147	184	227	291
Shipping dimensions (including pallet)	L x W x H mm	1200 x 870 x 640	1200 x 870 x 640	1200 x 870 x 640	1520 x 870 x 640	1940 x 920 x 640
Number of burners		4	6	8	10	12
Cooking surface area	M <sup>2</sup> (W x D mm)	(535 x 530)	(890 x 530)	(1070 x 530)	(1420 x 530)	(1720 x 530)
Drip tray volume (each)	Litres (max)	13.7	9.3	13.2	18.1	14.1
Drip tray quantity		1	2	2	2	3
Total burner rating (heat input) natural gas	kW (Btu/hour)	14.8 (50500)	22.2 (75770)	29.6 (101025)	37.0 (126275)	44.4 (151540)
Total burner rating (heat input) butane	kW (Btu/hour)	14.4 (49160)	21.6 (73740)	28.8 (98320)	36.0 (122900)	43.2 (147480)
Total burner rating (heat input) propane	kW (Btu/hour)	12.4 (42320)	18.6 (63480)	24.8 (84640)	31.0 (105800)	37.2 (126960)
Typical rate of ventilation based on 54m <sup>3</sup> /minute per m <sup>2</sup> of appliance.	m <sup>3</sup> /minute	28	40	52	67	80

**TABLE 3. BURNER AND PILOT JET SIZES.**

Gas	P mbar	Jet description	Jet diameter
G20	20	Burner Orifice	1.40 mm (0.055")
		Pilot Orifice	0.41 mm (0.016")
G30	20	Burner Orifice	1.0 mm (0.039")
		Pilot Orifice	0.25 mm (0.010")
G31	25	Burner Orifice	1.0 mm (0.039")
		Pilot Orifice	0.25 mm (0.010")

**TABLE 4. GAS CATEGORY AND PRESSURES.**

Country code	Category index	Ref Gas	P mbar	
			Inlet	Manifold
AT CH DK ES FI FR GB GR IE IT LU NL PT RO SE	I <sub>2H</sub>	G20	20	20
DE PL RO	I <sub>2E</sub>	G20	20	20
BE FR	I <sub>2E+</sub>	G20	20/25	20
BE ES FI FR GB GR IE PT	I <sub>3B</sub>	G30	29	20
FR GR	I <sub>3B</sub>	G30	50	20
NL FI RO	I <sub>3P</sub>	G31	30	25

Country code	Category index	Ref Gas	P mbar	
			Inlet	Manifold
BE CH CZ ES FR GB GR IE IT NL PL PT	I <sub>3P</sub>	G31	37	25
BE CH CZ ES FR GB GR IE IT NL PL PT	I <sub>3P</sub>	G31	50	25

**TABLE 5. CONSUMPTION AND ENERGY USAGE FOR G20 NATURAL GAS.**

The following table is based on actual test results for natural gas.

Model	Number of burners	Pilot burner		Half flame main burner		Full flame main burner	
		Gas consumption	Energy usage	Gas consumption	Energy usage	Gas consumption	Energy usage
		M <sup>3</sup> /hr	kWh	M <sup>3</sup> /hr	kWh	M <sup>3</sup> /hr	kWh
BCB600	4	0.072	0.8	0.504	5.6	1.332	14.8
BCB900	6	0.108	1.2	0.756	8.4	1.998	22.2
BCB1200	8	0.144	1.6	1.008	11.2	2.664	29.6
BCB1500	10	0.180	2.0	1.260	14.0	3.330	37.0
BCB1800	12	0.216	2.4	1.512	16.8	3.996	44.4

Calorific value for natural gas taken as 39.02778 MJ/m<sup>3</sup>

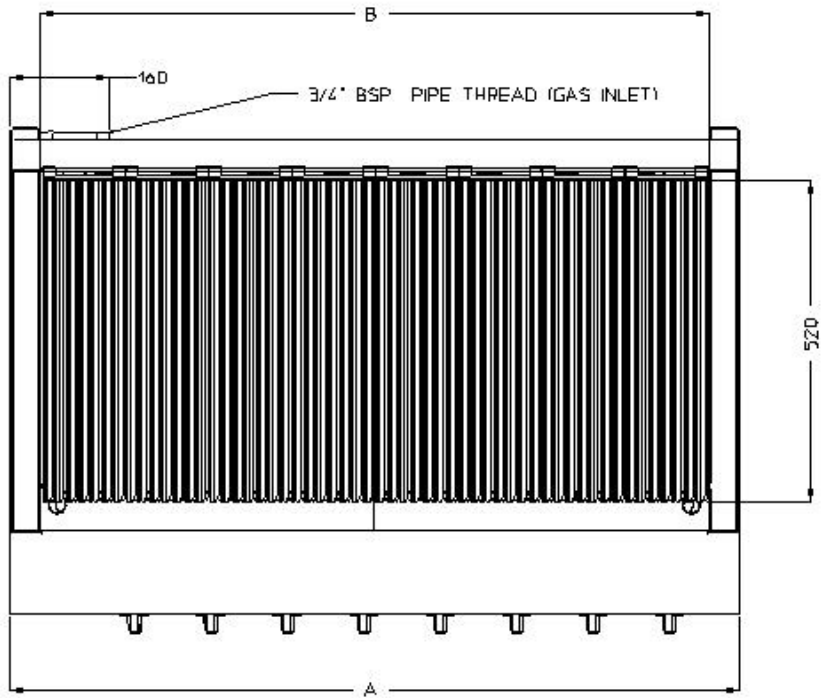

**FIGURE 1. INSTALLATION DIMENSIONS** (pictorial example is a BCB1200 refer to table 2 below for all models).

Model	Units	A	B	C	D
BCB600	mm	643	543	592	488
BCB900	mm	914	814	863	333
BCB1200	mm	1185	1085	1134	469
BCB1500	mm	1535	1435	1484	644
BCB1800	mm	1844	1744	1793	502

**TABLE 6. BCB DIMENSIONS.**

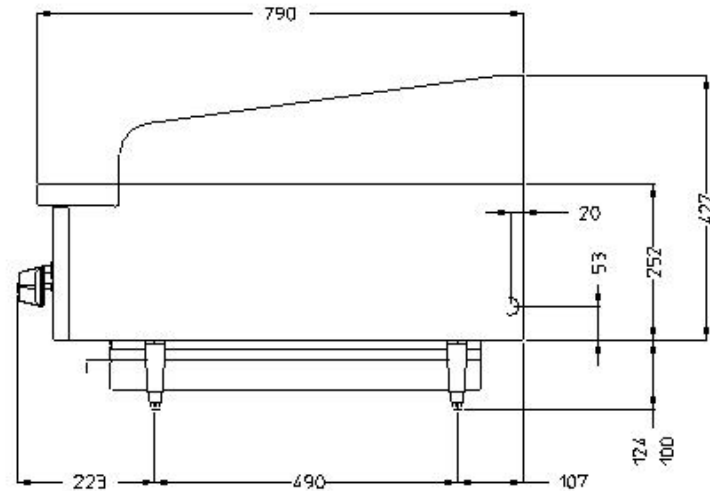
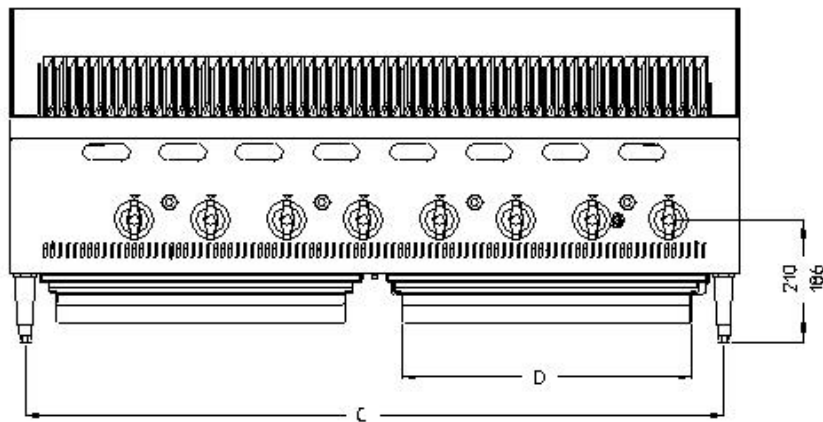

## 8.0 INSTALLING THE CHAR BROILER.

In order to ensure a safe and satisfactory installation it is important that discussions take place between those involved with the kitchen design, selection of the BCB char broiler, layout and installation of the equipment. The BCB must be installed by a competent person to ensure safe and hygienic operation. Consideration must be given to catering and food hygiene.

### 8.1 UNPACKING AND HANDLING.

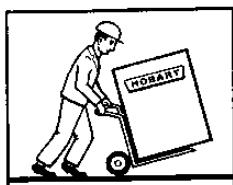

Wherever possible the appliance should be transported to the installation position in the packaging provided to avoid damage. Do not use a sharp knife to cut into the packaging as damage to the machine may occur. Check for possible shipping damage. If the unit is found to be damaged, save the packaging material and contact your nearest Hobart sales office.



**Caution:** The BCB Char Broiler is a heavy object and must be correctly handled and lifted to avoid personal injury. Refer to table 2 for weights and dimensions. For UK installations refer to the 'Manual Handling Operations Regulations 1992 and HSE guidance notes for manual handling.

With the appliance in the vicinity of its final position remove the shrink wrap film and wood protecting the control knobs. Lift off the grates and radiants and remove the unit from the transportation pallet.

Care must be taken during this operation to ensure: -

- a) All required safety measures are taken to ensure correct lifting and handling to avoid risk of injury through dropping, falling and tilting.
- b) No damage occurs to the machine, which could impair the normal operation.

### 8.2 LOCATION.

The BCB Char Broiler is not suitable for outdoor installation and must not be installed where a water jet could be used for cleaning. The appliance must only be operated by trained staff and must be installed in an area where the use and maintenance is restricted to trained personnel.

This appliance shall be installed in conformity with the current regulations (BS6173) and used only in a well-ventilated location. Consult the instructions before installing and using this appliance.

The LPG version of the BCB must not be installed in a room that does not have the means of low level natural ventilation direct to outside (for example in a basement or cellar). The correct procedure must be used for ventilation inside and around the gas cylinder compartment at all times. There must be a permanent supply of fresh air and no accumulation of un-burnt gases.



The appliance must be installed with sufficient ventilation to prevent the occurrence of unacceptable concentrations of substances harmful to health in the room in which they are installed.

**Important!** Ensure there is sufficient space around the BCB to enable safe operation. Servicing may be more difficult because of reduced clearances and you should always check that equipment specifications permit the close proximity of other equipment. Refer to table 1 for minimum clearances. Service access is required to the front, bottom, sides and top of the appliance. It is suggested that at least 600 mm of free area be provided to the front of the unit. Do not weld the appliance into a work top or counter. This will make service access very difficult.

### **8.3 GENERAL INSTALLATION GUIDELINES.**

The BCB Char Broiler should not be located adjacent to customer services where hot surfaces may cause burns.

The BCB Char Broiler must not be installed next to open burners or fryers. Other types of gas fired appliances can be positioned adjacent to the BCB Char Broiler however there must not be any obstruction to the front.

Before proceeding with the installation, remove the protective plastic film from all panels including the heat reflector cassette and under side of the drip trays. Use an appropriate cleaning product to remove any adhesive residues from the stainless steel.

The gas supply tubing or hose must comply with national requirements in force and must be periodically examined and replaced as necessary.

When installing the char broiler never enclose the unit's lower area in any way that would obstruct the flow of air into the appliance.

Crevices need to be avoided between and behind the appliance and the pipe work where any spillage may lodge.

All supports, shelves and wall finishes not directly in contact with the appliance must be capable of withstanding a minimum temperature of 65°C and be non-combustible.

Any panels or splash backs secured directly to the appliance must be non-combustible.

The BCB must be secured in position to prevent any movement. Restraints must not be fixed to the gas supply pipes or points not sufficiently anchored.

For any 'work' performed in the UK on the appliance, including installation that is within the scope of the Gas Safety (Installation and Use) Regulations shall be carried out by a business that is Gas Safe approved (Council for Registered Gas Installers) and approved by the Health and Safety Executive (HSE).

The BCB Char Broiler shall have a single manual isolating gas valve to be used when servicing or cleaning.

A manual operation valve should be fitted to the gas supply in the catering area to enable the system to be isolated in an emergency. Ideally this valve should be located outside the catering area or near an exit in a readily accessible position.



On completion of the installation a leak test must be performed. CAUTION! A naked flame must not be used for this purpose. Some leak test solutions may cause corrosion therefore thorough rinsing with water is required after testing. Read the leak detector instructions for use.

#### **8.4 MOUNTING OF THE APPLIANCE.**

The BCB Char Broiler must be mounted on a flat surface. The appliance is supplied with 4 off legs 100 mm high (4") to ease cleaning underneath. This appliance is not suitable for building in to other appliances.

Select a suitable flat level surface that can support the weight of the BCB Char Broiler and food product (refer to table 2 for weights and dimensions). The unit must be installed on a horizontal flat surface. Once the appliance is in position adjust the feet to ensure the unit is level to within 1mm in 1 metre side to side and front to back. The BCB Char Broiler must be adequately secured and restrained in position.

#### **8.5 GAS PIPE WORK.**

The installation of the gas pipe work in the UK must be in accordance with latest revision of standard BS6173.

- Gas pipe work must be installed in a sound and workman-like manner and be constructed of materials suitable for its purpose.
- Pipes conveying gas must be adequately identified.
- For rigidly fixed pipe work a union or similar method of disconnection must be provided between the isolation valve and appliance.
- The clearance between the gas pipe and wall must be at least 25mm to ease cleaning.
- Semi-rigid pipe must conform to BS7838 and only be installed in a ventilated area where it cannot be damaged.
- If a flexible connection is installed it must not touch the floor or be exposed to excessive heat.
- The gas outlet to which the connection is made must be located in the same room as the appliance.
- If a flexible connection is used it must not be concealed within or routed through any wall or partition.
- Flexible gas connections must not come into contact with sharp edges or wiring.

#### **8.6 VENTILLATION.**

Provision is required for adequate dispersal of combustion and cooking fume products, supply of combustion air and ventilation for the appliance and cooking processes. Adequate fresh air is required in kitchens to provide air for combustion to limit the effects of heat and humidity (reference must be made to HVCA DW/171 to ensure there is adequate ventilation for the appliance). Refer to table 2 for the typical ventilation rate. Consideration must be made for other gas appliance that may be in the same area as the BCB Char Broiler.

This type 'A1' appliance is not designed to be connected to a flue or other device for evacuating the combustion products to the outside of the room where it is installed. The appliance must be installed in a suitably ventilated room in accordance with current regulations (BS6173).

It is advisable that a hood is fitted above the appliance to ensure effective extraction of moisture, combustion fumes and cooking odours. The plan dimension of the canopy should exceed the plan area of the BCB Char Broiler by an overhang of 250mm at the front and 150mm at the sides. The hood and ductwork must be constructed from non-combustible material. Table 2 specifies the ventilation airflow requirement.

For new installations the gas supply to the appliance must be interlocked with any mechanical ventilation system fitted to ensure safe operation of the appliance.

The BCB must not be installed in a catering area where the ventilation system could adversely affect its safe operation.

Broiling produces greasy cooking odours and vapours that require filtration. The filters must be reviewed frequently and cleaned on a regular basis (at least every month).

The BCB Char Broiler must be supported on a suitably designed surface that will withstand the weight of the appliance and food product. The appliance must be restrained to prevent any movement during use.

Low level ventilation is always required for appliances using a gas (LPG) heavier than air.

It is strongly recommended that a flammable gas and CO detector is fitted that is suitable for catering environments.

## **8.7 GAS INSTALLATION.**



When installed in the United Kingdom the installation must conform to the Gas Safety (Installation and Use) Regulations. This appliance must be earthed as shown in section 8.8.

It is strongly recommended that a flexible connection be used for the gas supply to the appliance.

Refer to table 2 and the appliance data plate to ensure there is an adequate supply of gas. Check that the gas type and gas pressure is consistent with the gas supply of the BCB. If the appliance is not suitable for the gas being supplied it shall not be installed or connected to the gas supply.

Conversion of the appliance from one gas to another must be carried out strictly in accordance with Hobart instruction's by a competent person.

## **8.8 FITTING THE GAS REGULATOR.**

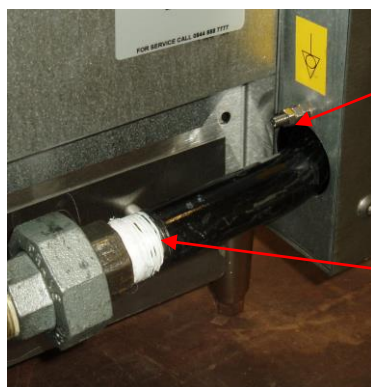

Earth bonding  
screw.

Gas inlet  
connection.

**PHOTOGRAPH 20.**  
**EQUIPOTENTIAL AND GAS INLET CONNECTION.**

A gas regulator is not required with the natural gas version of the BCB appliance provided the supply pressure complies with the values given in table 1. However if a regulator is required fit as follows:

1. The Char Broiler gas inlet pipe connection is a  $\frac{3}{4}$ " BSP male thread. Apply suitably approved jointing compound to the threads.
2. Use a coupling between the regulator and gas manifold.
3. Using a spanner tighten the gas regulator on to the appliance. Note the direction of gas flow arrow.

The gas regulator must be installed in a position where it is accessible for adjustment by a competent person but not available for unauthorised interference. Suitable gas regulators are available from Hobart. Refer to section 11 for part numbers.

## **8.9 ELECTRICAL EARTH BONDING CONNECTION.**

Where necessary for electrical safety the BCB Char Broiler should be earth bonded using the screw shown in photograph 20. Check the earth bonding resistance is less than  $0.1\Omega$ .

## **9.0 COMMISSIONING INSTRUCTIONS.**



This BCB Char Broiler is only intended for professional use by suitably trained people. Ensure operators have read and understood this manual and have received adequate training.

The installation of the appliance must be commissioned by a competent person using the instructions. In the UK the installation must be in accordance with BS6173.

All new gas pipes upstream of the appliance must be tested for soundness and purged of air before igniting the pilot burners. This can take several minutes depending on the length of gas pipe to the appliance. Adjust the gas control knob to the pilot burner position and press 'in' to allow the gas to flow through the pipe work.

During commissioning check the correct operation of the flame failure valve, thermocouple and the burner pressure is adjusted to the value given in the technical information table 1 and on the data plate.

All pipe work between the isolating valve and BCB Char Broiler must be tested for leaks with no perceptible drop in water pressure gauge over a period of two minutes at a pressure at least the operating pressure and not more than 1.5 times the operating pressure. Following pressure testing the pipe work must be purged of air.

## **9.1 TO CHECK THE MANIFOLD GAS INLET PRESSURE.**

1. The gas inlet pressure to the appliance must be checked using a 0.80 m bar WG manometer with an accuracy of at least 0.05 m bar WG.
2. Remove the screw from the 9mm-diameter pressure test nipple. The pressure test nipple is situated on the front of the appliance (see photograph 21).
3. Connect a silicone rubber tube to the manometer and test nipple. Ignite the pilot and main burner and check the operating inlet pressure. Refer to table 1 for the correct pressure.
4. Adjust the gas regulator (if fitted) to achieve the required pressure.
5. Replace the screw into the pressure test nipple and check for soundness with a gas leak detector solution.



**PHOTOGRAPH 21. GAS TEST NIPPLE.**



**PHOTOGRAPH 22. GAS INLET PRESSURE MANOMETER.**

## **9.2 OPERATOR TRAINING.**

Take time to explain the correct operation and cleaning of the BCB Char Broiler to the chefs making reference to this manual. Leave this manual with the operator and explain that it is important for further reference.

## **10.0. MAINTENANCE.**

The frequency of service maintenance will depend on customer usage. Refer to table 8, section 12 for recommended service intervals.

The BCB Char Broiler must not be modified other than as specified by Hobart UK. **A competent person shall carry out all servicing and maintenance work.**

If the appliance restraints are disconnected in order to remove it for servicing a notice must be fixed near the restraint reminding the operator to reconnect the restraint and any electrical earth bonding.

1. All moving parts must be checked for wear and lubricated, if necessary. Replace if excessively worn.
2. The burner ports and throats should be thoroughly cleaned. The burner orifice must be free from grease and lint. When cleaning **DO NOT** insert a pick in the burner porthole.

3. BCB Char Broilers equipped with appliance restraints should be checked by a competent person to ensure proper installation.
4. All places where oil, grease, or food can accumulate must be kept clean at all times.
5. Pilot lights are to be kept clean and adjusted to the correct flame height to ensure constant ignition and to prevent fire flash-outs caused by delayed ignition.
6. At the first sign of sticking, all valves and controls should be lubricated by a trained person using high temperature grease.
7. At the slightest smell of gas, all fittings, pipes, tubing and controls should be tested with a gas leak detector solution.
8. The gas supply tubing or hose must comply with national requirements in force and must be periodically examined and replaced as necessary.

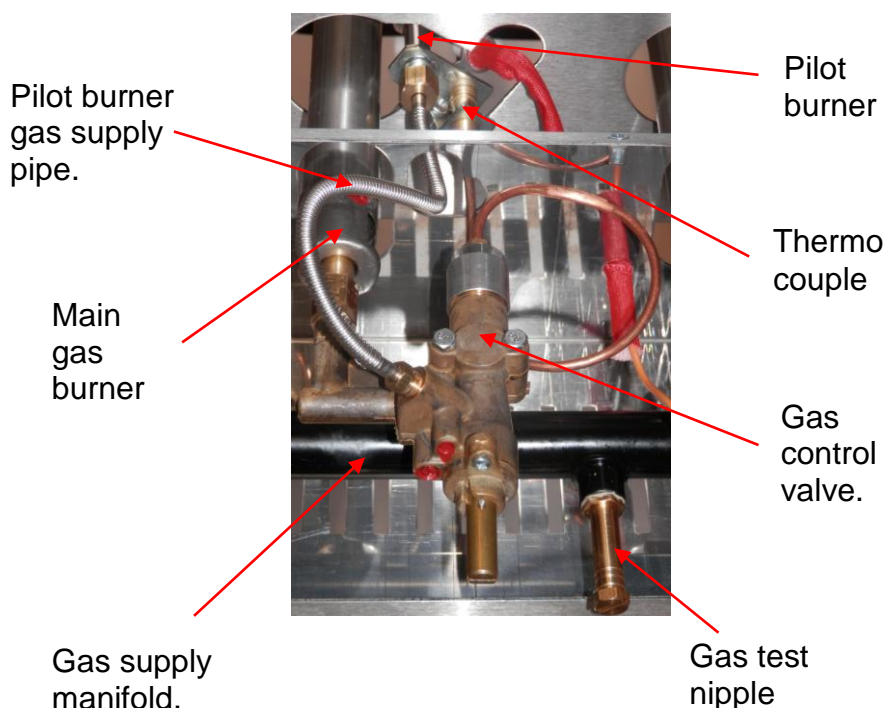

**GAS CONTROL SYSTEM COMPONENT IDENTIFICATION. PHOTOGRAPH 23.**

### **10.1 ADJUSTING THE PILOT BURNER FLAME.**

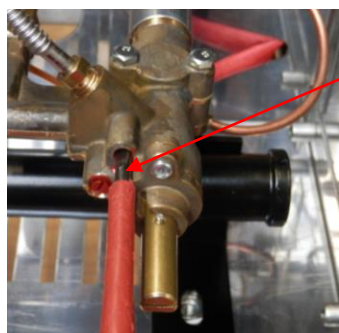

PILOT BURNER FLAME ADJUSTMENT SCREW. MUST BE TURNED CLOCKWISE TO THE MINIMUM SETTING.

**NOTE! THE PILOT BURNER FLAME MUST ONLY BE ADJUSTED BY A COMPETENT AND AUTHORISED PERSON.**

**PILOT BURNER FLAME ADJUSTMENT SCREW. PHOTOGRAPH 24.**

The pilot burner flame must be stable and have an even and adequate coverage on the thermocouple without flame lifting. The flame length should be between 10 to 15 mm.

Air shutters situated on the main burners are factory set to the maximum opening and the screw marked with red paint.

If a new gas valve is fitted the pilot burner adjustment screw must be set to the minimum setting and marked with red paint.

Using a 4 mm wide slotted screw driver adjust the pilot burner screw clockwise to the full extent of its travel (refer to photograph 24). Mark the thread with red paint. Ensure the flame does not lift off the thermocouple when adjusted. This is particularly important if the appliance is located directly adjacent to a strong ventilation system.

## 10.2 REPLACING THE PILOT BURNER.

**NOTE! THE PILOT BURNER MUST ONLY BE REPLACED BY A COMPETENT AND AUTHORISED PERSON.**



**WARNING!** Before attempting to remove the grates ensure they are at an acceptable temperature to touch. This will normally take approximately 3 hours after using with the main burner.

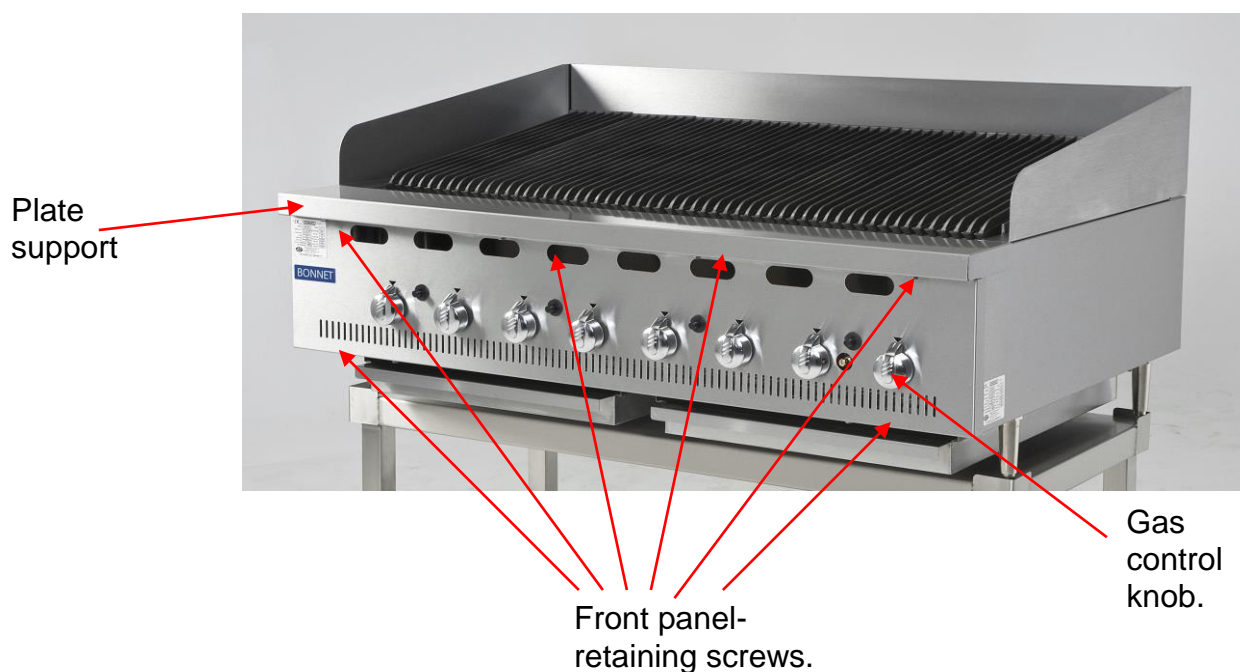

### **FRONT PANEL RETAINING SCREWS (BCB1200 SHOWN). PHOTOGRAPH 25.**

To replace the pilot burner assembly follow the instructions detailed below. Photograph 23 shows the view of the manifold and pilot burner after the plate support and gas manifold cover are removed.

1. Isolate the gas supply to the appliance.
2. Carefully remove the grates and radiants
3. The pilot burner cover is secured using keyhole slots and screws. Lift the cover up and away from the locating screws (refer to photograph 26).

4. The pilot burner can be accessed through the top of the appliance by removing the plate support shown in photograph 25 and removing the cover over the gas manifold assembly shown in photograph 27.
5. Pull off the relevant electrode wire from the piezo igniter.
6. Unscrew the thermocouple brass retaining nut and the pilot burner gas pipe brass nut (refer to photograph 29).
7. Remove the screw securing the pilot burner assembly to the bracket as shown in photograph 28 and withdraw.
8. Replacement is the reverse of the above procedure. After assembly check for gas leaks with a suitable leak detection fluid.

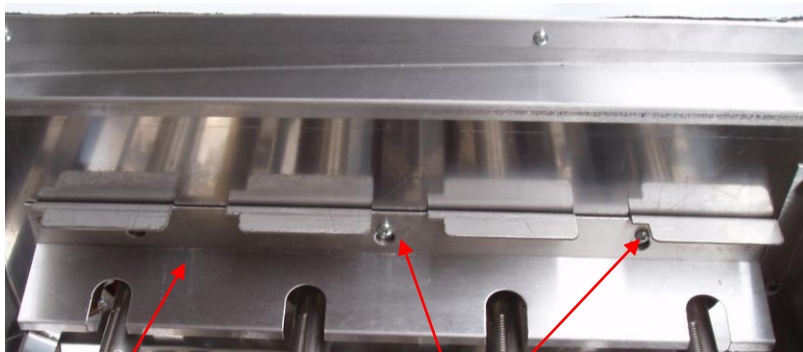

Pilot burner cover.

'Key hole' slots.

**PILOT BURNER DEFLECTOR COVER. PHOTOGRAPH 26.**



M4 hex headed screw

Posi-drive screw

Gas manifold cover

**GAS MANIFOLD ASSEMBLY COVER PLATE. PHOTOGRAPH 27.**

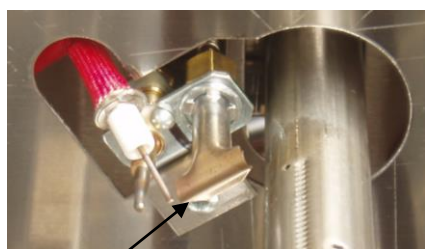

Mounting screw.

**PILOT BURNER ASSEMBLY. PHOTOGRAPH 28.**



## 10.3 REPLACING THE THERMOCOUPLE.

**NOTE! THE PILOT BURNER MUST ONLY BE REPLACED BY A COMPETENT AND AUTHORISED PERSON.**



**WARNING!** Before attempting to remove the grates ensure they are at an acceptable temperature to touch. This will normally take approximately 3 hours after using with the main burner.

Access to the thermocouple is from underneath the grates.

1. Isolate the gas supply to the appliance.
2. Carefully remove the grates and radiants
3. The pilot burner cover is secured using keyhole slots and two screws. Lift the cover up and away from the locating screws (refer to photograph 26).
4. The thermocouple can be accessed through the top of the appliance by removing the plate support shown in photograph 25 and removing the cover over the gas manifold assembly shown in photograph 27.
5. Unscrew the brass retaining nut securing the thermocouple to the mounting bracket (refer to photograph 28).
6. Un-screw the retaining nut situated on the gas valve and withdraw the thermocouple from the appliance. Take care not to loose the brass spacer.
7. Replacement is the reverse of the above procedure. Ensure the brass spacer is correctly fitted as shown in photograph 30.

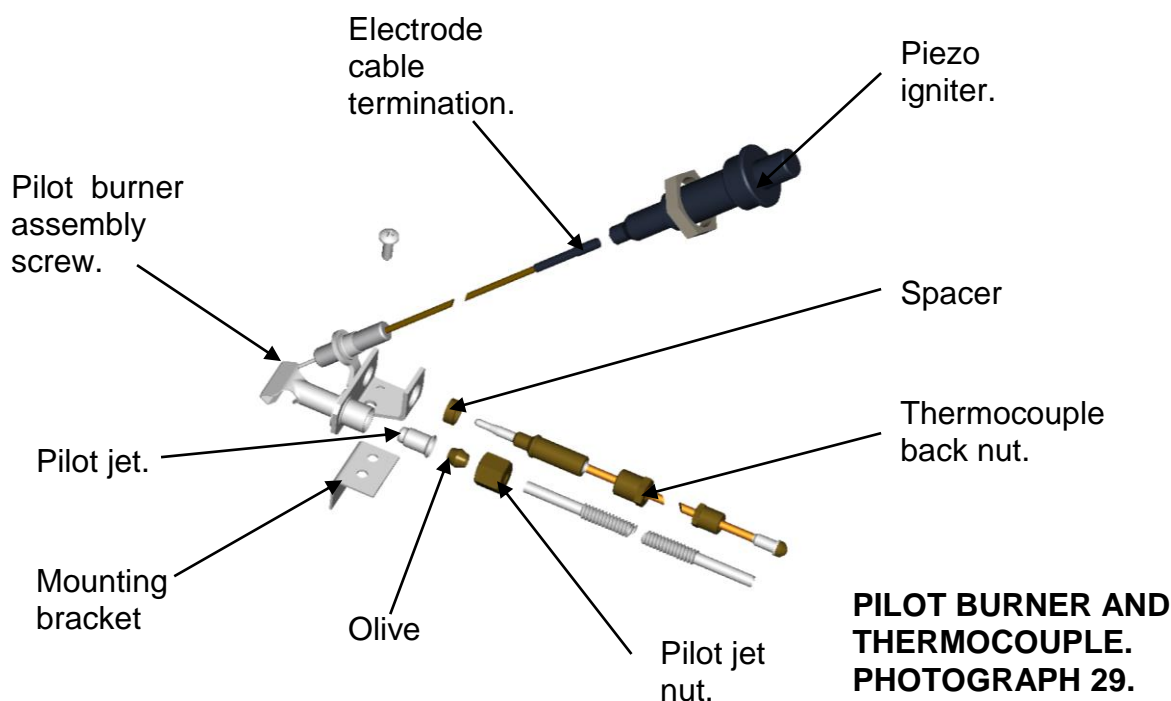

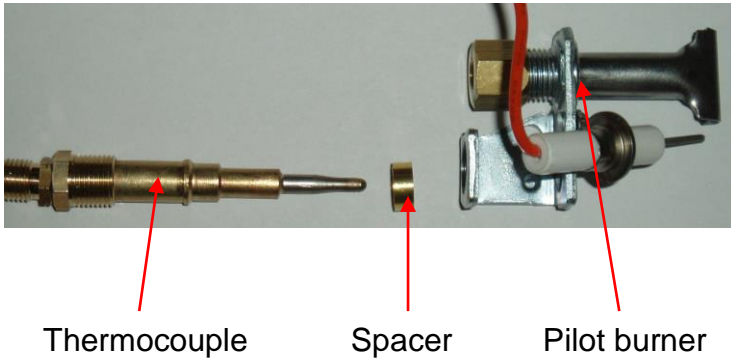

Thermocouple      Spacer      Pilot burner

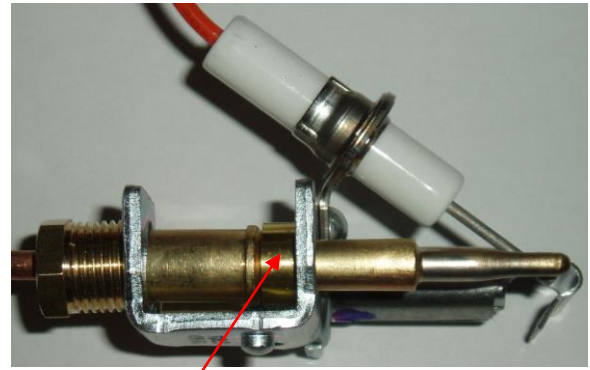

Spacer

**PHOTOGRAPH 30. THERMOCOUPLE AND PILOT BURNER ASSEMBLY.**

**10.4 REPLACING THE MAIN BURNER.**



**NOTE! THE MAIN BURNER MUST ONLY BE REPLACED BY A COMPETENT AND AUTHORISED PERSON.**

WARNING! Before attempting to remove the grates ensure they are at an acceptable temperature to touch. This will normally take approximately 3 hours after using with the main burner.

Access to the main burner is from underneath the grates.

- 1 Ensure the unit is cool to the touch before commencing any work.
- 2 Isolate the gas supply to the appliance.
- 3 Carefully remove the grates and radiants



Split pin

**MAIN BURNER SPLIT PIN. PHOTOGRAPH 31.**



**MAIN BURNER REMOVAL. PHOTOGRAPH 32.**

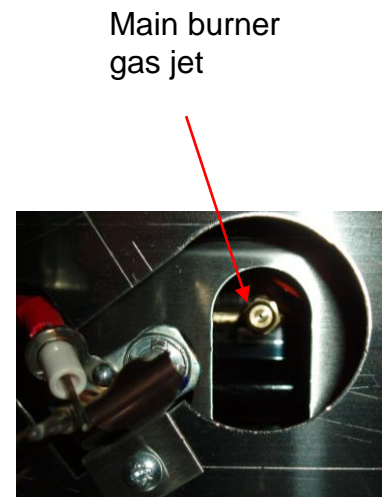

Main burner gas jet

**MAIN BURNER GAS JET PHOTOGRAPH 33.**

- 4 The pilot burner cover is secured using keyhole slots and screws. Lift the cover up and away from the locating screws as shown in photograph 26.
- 5 Using a pair of pliers remove the split pin from the end of the burner (photograph 31)).
- 6 Lift the rear end of the burner up and to one side in order to withdraw from the appliance as shown in photograph 32.
- 7 Replacement is the reverse procedure; however ensure the open end of the burner locates correctly onto the gas jet. Photograph 33 shows the location of the jet.
- 8 Fit a new stainless steel split pin as shown in photograph 31.

## **10.5 REPLACING THE MAIN BURNER JET.**

**NOTE! THE MAIN BURNER JET MUST ONLY BE REPLACED BY A COMPETENT AND AUTHORISED PERSON.**



**WARNING!** Before attempting to remove the grates ensure they are at an acceptable temperature to touch. This will normally take approximately 3 hours after using with the main burner.

1. Ensure the unit is cool to the touch before commencing any work.
2. Isolate the gas supply to the appliance.
3. Carefully remove the grates and radiants
4. Remove the main burner as detailed above.
5. The jet can be accessed by removing the plate support without removing the front panel.
6. Remove the upper hexagon headed screws securing the front panel to the plate support and the screws securing the plate support to the fat gulley as shown in photograph 25 and remove the cover over the gas manifold assembly shown in photograph 27.
7. Lift the plate support and pull forward from the appliance.
8. The main burner jets can now be accessed.
9. Un-screw the burner jet from the gas valve.
10. Replacement is the reverse procedure. The size is identified on the body of the jet. Ensure the open end of the burner locates correctly onto the gas jet. After assembly check for gas leaks with a suitable leak detection fluid.
11. Check the main burner flame pattern and adjust the air shutter if necessary. The air shutter is factory set to the maximum opening.

Main burner jet.

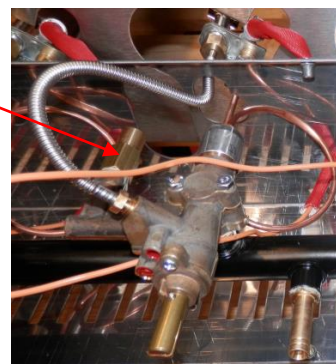

**MAIN BURNER JET.  
PHOTOGRAPH 34.**

## **10.6 REPLACING THE GAS CONTROL VALVE.**

**NOTE! THE GAS CONTROL VALVE MUST ONLY BE REPLACED BY A COMPETENT AND AUTHORISED PERSON.**



**WARNING!** Before attempting to replace the gas control valve ensure the appliance is at an acceptable temperature to touch.

1. Isolate the gas supply to the appliance.
2. The gas control valve can be accessed by removing the plate support without removing the front panel.
3. Remove the upper screws securing the front panel to the plate support and the screws securing the plate support to the fat gulley as shown in photograph 25 and remove the cover over the gas manifold assembly shown in photograph 27.
4. Pull off the chrome control knob.
5. Unscrew the pilot burner gas supply pipe nut and thermocouple retaining nut as shown in photograph 35.
6. Remove the two screws securing the gas valve to the manifold and carefully lift off the valve assembly as shown in photograph 36.
7. Check the condition of the sealing O ring and replace if necessary.
8. Replacement of the gas valve is the reverse of the above procedure. After assembly check for gas leaks with a suitable leak detection fluid.



**GAS CONTROL VALVE ASSEMBLY. PHOTOGRAPH 35.**

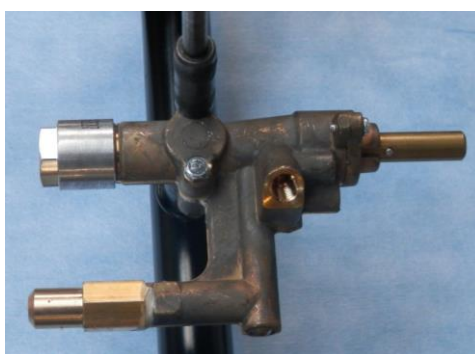

**GAS CONTROL VALVE. PHOTOGRAPH 36.**



**GAS CONTROL VALVE SEAT AND O RING. PHOTOGRAPH 37.**

## **10.7 ADJUSTING THE MAIN BURNER LOW FLAME.**

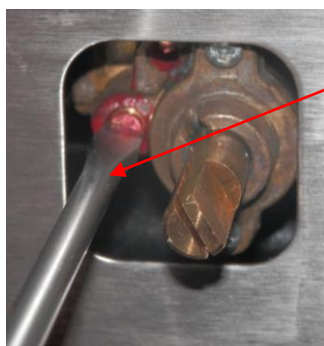

**MAIN BURNER LOW FLAME ADJUSTMENT SCREW. TURN ANTI-CLOCKWISE TO INCREASE FLAME SIZE.**

**NOTE! THE MAIN BURNER FLAME MUST ONLY BE ADJUSTED BY A COMPETENT AND AUTHORISED PERSON.**

**MAIN BURNER LOW FLAME ADJUSTMENT SCREW. PHOTOGRAPH 38.**

The low flame heat position is factory set and the adjustment screw sealed with tamper proof red paint.

If a new gas valve is fitted to the appliance use a 4 mm wide slotted screw driver and adjust the screw fully clockwise to the full extent of the travel.

## **10.8 NATURAL GAS TO PROPANE/BUTANE APPLIANCE CONVERSION.**

A conversion kit is available as listed in the spare parts section 13. The conversion instructions are detailed on a separate document Hobart part number: ETI-PC-456. For gas conversion please contact Hobart UK.

## **11.0 FAULT FINDING AND REMEDIAL ACTION.**

**NOTE! ONLY A FULLY TRAINED AND COMPETENT PERSON MUST USE, INSTALL, MAINTAIN AND SERVICE THE BCB BONNET CHAR BROILER.**

### **11.1 FAULT FINDING SUMMARY. TABLE 7.**

<b>Fault</b>	<b>Possible cause</b>	<b>Remedy</b>
Pilot flame fails to ignite.	Gas supply isolated to appliance	Check gas isolation valve and open if necessary.
	Gas supply pipe requires purging	Purge gas supply pipe.
	Blocked pilot jet	Remove pilot jet and clean
	Failed regulator	Check regulator and replace as necessary.
	Incorrect gas regulator pressure setting.	Pressure regulator requires adjustment.
	Gas control knob not set to correct position.	Re-adjust control knob to pilot flame position.
	Failed gas control valve.	Check and replace as necessary.
No spark at the electrode.	Piezo igniter failure.	Replace the piezo igniter.
	High tension cable shorting to earth	Check the condition of the cable and replace if necessary.
	Poor electrical connection to the piezo igniter	Check cable connection to the piezo igniter.
Pilot flame fails to remain ignited	Thermocouple not heated sufficiently.	Wait 3 minutes and ignite pilot burner, hold the control knob in for 20 seconds to heat the thermocouple.
	Pilot flame too small	Check flame height and adjust as necessary.
	Incorrect gas regulator pressure setting (if fitted).	Pressure regulator requires adjustment.
	Failed thermocouple.	Check and replace as necessary.
	Failed gas control valve.	Check and replace as necessary.
	Ventilation draft too great.	Check the rate complies with table 2.
Main burner fails to ignite.	Gas supply isolated to appliance	Check gas isolation valve and open if necessary.
	Incorrect gas regulator pressure setting.	Pressure regulator requires adjustment.
	Failed gas control valve.	Check and replace as necessary.
	Appliance still fails to operate	Call local Hobart service centre.
Smell of gas	Leak from pipe or joint.	Isolate gas supply, ventilate room and call Hobart Service.

## 12.0 SERVICE MAINTENANCE



**A HOBART TRAINED AND COMPETENT PERSON SHOULD CARRY OUT SERVICING.**

Do not remove any covers or loosen any fittings while the BCB Char Broiler is operating. Ensure the gas supply has been isolated before attempting to service or move the appliance.

It is recommended that the appliance be serviced regularly depending on the customer usage as summarised in the table below. Refer to section 10 for more detailed maintenance information. It is recommended that servicing is only carried out by Hobart trained service personnel. For further information on Hobart service contracts contact our service division on **0844 888 7777**.

**TABLE 8. RECOMMENDED SERVICE INTERVALS.**

Hours of use per day	Service interval
10 to 12 hours per day, 7 days per week	Every 30 to 60 days
4 to 6 hours per day, 5 days per week	Every 3 months
Limited daily usage	Every 6 months

## 13.0 SPARE PARTS. TABLE 9.

Refer to the spare parts manual (Hobart part number: PLE200538) for exploded views and additional part number.

Part number	Description	BCB600	BCB900	BCB1200	BCB1500	BCB1800
		Qty per appliance	Qty per appliance	Qty per appliance	Qty per appliance	Qty per appliance
00-739881	Burner, natural gas and Propane/ Butane	4	6	8	10	12
00-740064	Cleaning scoop	1	1	1	1	1
00-740154	Conversion kit - Natural gas to Propane/Butane	Optional extra (kit suits all models)				
00-739835-1	Drip tray	1				
00-739835-2	Drip tray		1			
00-739835-3	Drip tray			2		
00-739835-4	Drip tray				2	
00-739835-5	Drip tray					3
00-739397	Fry plate kit double width	Optional extra				
00-740116	Gas control valve	4	6	8	10	12
00-739029-3	Gas regulator (15 to 23 mb)	1	1	1	1	1
00-739029-2	Gas regulator (22 to 31 mb)	1	1	1	1	1
00-739858	Grate lifting tool	1	1	1	1	1
00-739857	Grate scraper tool	1	1	1	1	1
00-740979	Grate, angled 6 rib				3	1
00-740980	Grate, angled 7 rib	4	6	8	8	12

Part number	Description	BCB600	BCB900	BCB1200	BCB1500	BCB1800
		Qty per appliance	Qty per appliance	Qty per appliance	Qty per appliance	Qty per appliance
00-710423-1	Grate, straight 6 rib				3	1
00-710423	Grate, straight 7 rib	4	6	8	8	12
00-739833-1	Heat reflector cassette	1				
00-739833-2	Heat reflector cassette		1			
00-739833-3	Heat reflector cassette			2		
00-739833-4	Heat reflector cassette				2	
00-739833-5	Heat reflector cassette					3
143979-526	Hose –gas ¾" BSP 1.5 m long	Optional (available from Hobart UK)				
143979-543	Hose –gas ¾" BSP x 1 m long	Optional (available from Hobart UK)				
00-739808-3	Jet, natural gas	4	6	8	10	12
00-739808-7	Jet, main burner (Propane/Butane)	4	6	8	10	12
00-740487	Knob, chrome plated, push on	4	6	8	10	12
00-719260	Leg, adjustable	4	4	4	4	4
00-740116-1	Magnet unit flame failure	4	6	8	10	12
00-740478	Piezo igniter	2	3	4	5	6
00-740205	Pilot burner kit c/w electrode & natural gas orifice	4	6	8	10	12
00-739985-4	Pilot jet, natural gas	4	6	8	10	12
00-739985-2	Pilot jet (Propane/Butane)	4	6	8	10	12
00-710407	Radiant	4	6	8	10	12
144604-176	Restraint cable and fixings	1 off supplied with mobile stand.				
00-740068-1	Stand –mobile	1				
00-740068-2	Stand –mobile		1			
00-740068-3	Stand –mobile			1		
00-740068-4	Stand –mobile				1	
00-740068-5	Stand –mobile					1
00-740077-1	Stand –static	1				
00-740077-2	Stand –static		1			
00-740077-3	Stand –static			1		
00-740077-4	Stand –static				1	
00-740077-5	Stand –static					1
00-741053	Test nipple	1	1	1	1	1
00-738986-1	Thermocouple	4	6	8	10	12
00-740452-9	Tube-flexible, pilot burner	4	6	8	10	12

## **14.0 SERVICE CONTACTS**

Hobart trained service technicians strategically located at the listed Hobart branches are prepared to give you fast, efficient and reliable service. Protect your investment by having a Hobart inspection contract, which assures the continued, efficient operation of your Hobart machines, spares and accessories.

**For further detail contact: -**

**SALES, SERVICE AND SPARES:  
0844 888 7777**

Continued product improvement is a Hobart policy, specifications may change without notice.



Hobart UK  
Southgate Way  
Orton Southgate  
Peterborough  
PE2 6GN

Email: [customer.support@hobartuk.com](mailto:customer.support@hobartuk.com)  
Website: [www.hobartuk.com](http://www.hobartuk.com)

**PLE200537 – K 10-17 EU9412**