



First Choice Group

SPARE PARTS DIAGRAM FOR



Oven Range
CF4-78GP

First Choice Group
Blakeney Way, Kingswood Lakeside
Cannock, Staffs, WS11 8LD
TEL: 01543 577778 FAX: 01543504141
Email: enquires@firstchoice-cs.co.uk
Web: www.firstchoice-cs.co.uk



CF4-78GP >=20_1201#### <=20_1604####
Tav. 560043200M02P00

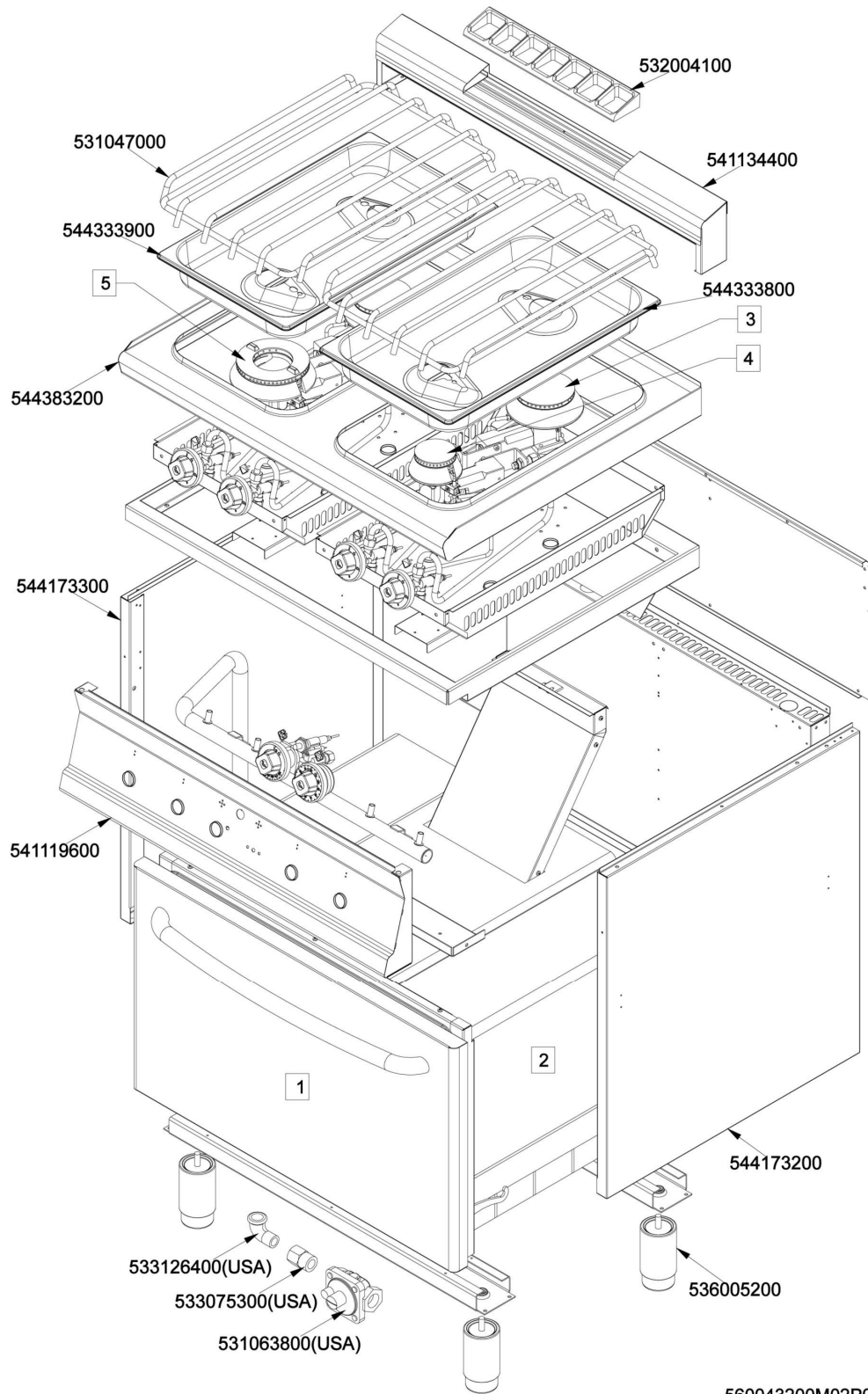

560043200M02P00



CF4-78GP >=20_1201#### <=20_1604#### - CF4-78GP

Code	Description	Price €
532004100	FLUE GRID L=370 90LINE (RAF)	51,50
531047000	2 BURNER GRID FOR PC-700	118,00
541134400	LOW SPACER 78 1 GRID	0,00
544333900	BURNER CONTAINER 1/1GN R 304	90,75
544333800	BURNER CONTAINER 1/1GN R 304	90,75
544383200	UPPER PLATE PC-78GP CF4-78GP/GPE	0,00
544173300	LEFT SIDE PANEL RANGE S.70	88,70
541119600	FRONT PANEL CF4-98G	0,00
544173200	RIGHT SIDE PANEL RANGE S.70	85,40
536005200	INOX LEG 2" 120-180 M10	17,50
-	-	
-	-	
-	-	
-	-	
-	-	



COMPONENTI COMUNI FORNO S70 GN2/1 GAS STATICO IMPIANTO V00 >=19_8501####
 <=20_9999####
 Tav. 560034700M03P00

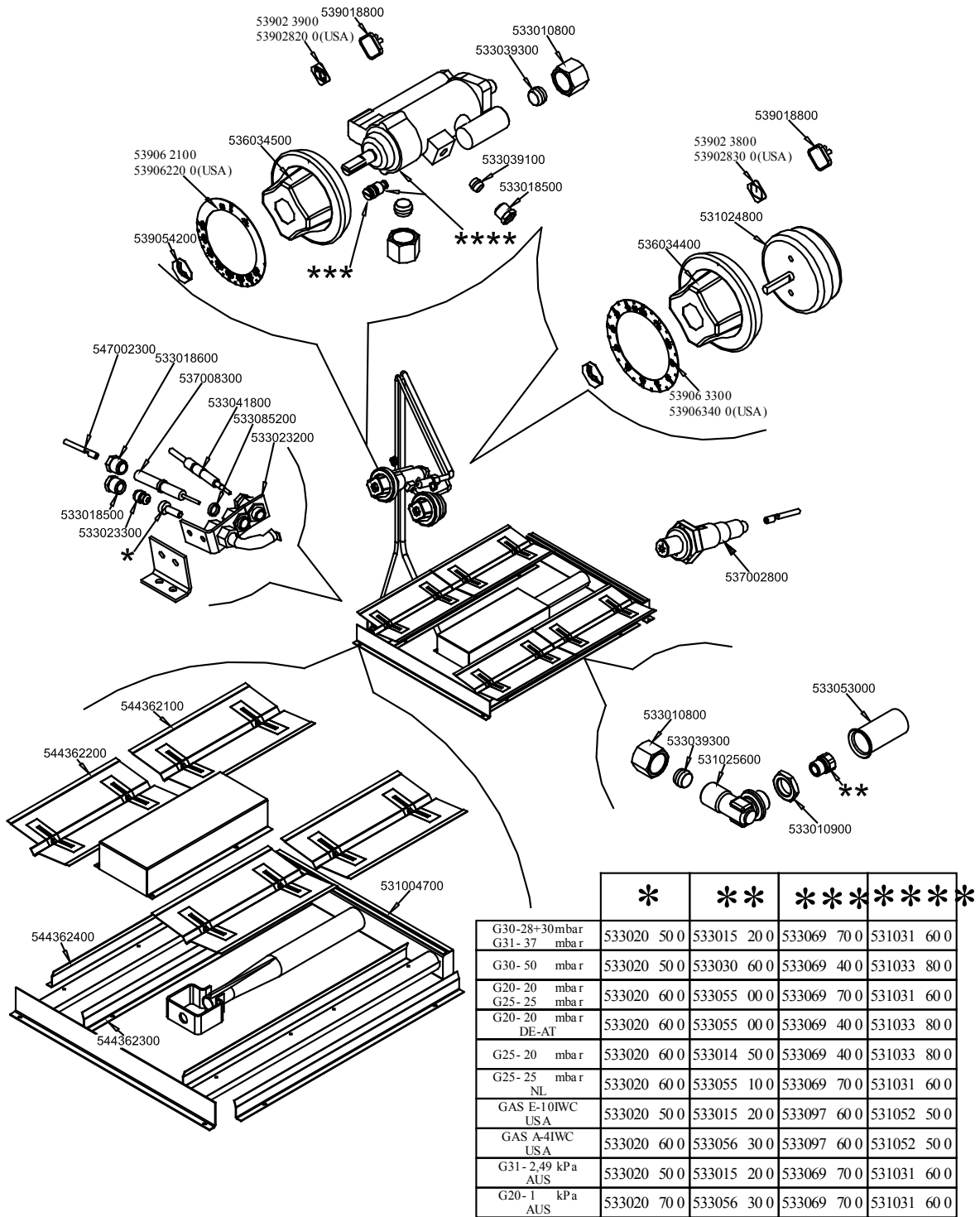

	*	**	***	****	*****
G30-28+30mbar G31-37 mbar	533020 50 0	533015 20 0	533069 70 0	531031 60 0	
G30-50 mbar	533020 50 0	533030 60 0	533069 40 0	531033 80 0	
G20-20 mbar G25-25 mbar	533020 60 0	533055 00 0	533069 70 0	531031 60 0	
G20-20 mbar DE-AT	533020 60 0	533055 00 0	533069 40 0	531033 80 0	
G25-20 mbar	533020 60 0	533014 50 0	533069 40 0	531033 80 0	
G25-25 mbar NL	533020 60 0	533055 10 0	533069 70 0	531031 60 0	
GAS E-10IWC USA	533020 50 0	533015 20 0	533097 60 0	531052 50 0	
GAS A-4IWC USA	533020 60 0	533056 30 0	533097 60 0	531052 50 0	
G31-2,49 kPa AUS	533020 50 0	533015 20 0	533069 70 0	531031 60 0	
G20-1 kPa AUS	533020 70 0	533056 30 0	533069 70 0	531031 60 0	



COMPONENTI COMUNI FORNO S70 GN2/1 GAS STATICO IMPIANTO V00 >=19_8501####
 <=20_9999#### - COMPONENTI COMUNI FORNO S70 GN2/1 GAS STATICO IMPIANTO V00

Code	Description	Price €
539018800	BLANK INDEX FOR KNOB	9,90
539023900	SIGN PLATE FOR OVEN TEMPERATURE	5,55
539028200	SIGN PLATE FOR OVEN TEMPERATURE	5,55
533010800	TUBE NUT D.10 M16*1,5	6,60
533039300	BICONE §10	5,55
539018800	BLANK INDEX FOR KNOB	9,90
539023800	LABEL FOR OVEN TIMER	5,55
539028300	SIGN PLATE FOR OVEN TIMER	5,55
531024800	TIMER 120'- 360°	34,00
536034400	KNOB §77 4P. §06*4,6 C/M	5,55
533039100	BICONE §6	5,55
533018500	FITTING FOR BICONE D.6 M10*1	4,55
536034500	KNOB §77 4P. §08*6,5	5,55
539062100	ADESIVE DISK FOR GAS OVEN S70	6,60
539062200	ADESIVE DISK FOR GAS OVEN S70 USA	6,60
539054200	STAMP Ø20,5 CR."L" LOTUS R.	6,60
547002300	HIGH-VOLTAGE CABLE §2 L=1900	0,00
533018600	PLUG FITTING	4,55
537008300	ROUND PLUG §2,4- LONG ELECTRODE	9,90
533041800	THERMOCOUPLE 1500 M9*1	18,75
533085200	SPACER FOR PILOT PLUG	3,20
533023200	"TARGET" PILOT + NIPPLE TC BRAC.90°	21,95
539063300	ADESIVE DISK FOR TYMER GREY	6,60
539063400	ADESIVE DISK FOR TYMER GREY USA	6,60
533018500	FITTING FOR BICONE D.6 M10*1	4,55
533023300	BICONE §6 ("TARGET" PILOT)	5,55
537002800	PIEZOELECTRIC IGNITION M18 WITH NUT	12,15
533053000	AIR ADJUSTMENT BUSHING §18	9,90
533010800	TUBE NUT D.10 M16*1,5	6,60
533039300	BICONE §10	5,55
531025600	ELBOW 90° NOZZLE-HOLDER §10 PIPE	9,90
533010900	NUT M14*1 H.4	5,55
544362100	UPPER BURNER DEFLECTOR FOR OVEN 70	9,90
544362200	UPPER PILOT DEFLECTOR FOR OVEN 70	9,90
531004700	BURNER FOR OVEN GN 2/1 S.70	105,00
544362400	SIDE PILOT DEFLECTOR FOR OVEN 70	11,00
544362300	SIDE BURNER DEFLECTOR FOR OVEN 70	11,00
533020500	NOZZLE 0.140 §19	5,55
533020600	NOZZLE 0.140 §27	5,55
533020700	NOZZLE 0.140 §35	5,55
533015200	NOZZLE §145 CH12*14 F-FP/CP6	6,60
533030600	NOZZLE §125 CH12*14	6,60
533055000	NOZZLE §205 CH12*14 G25 CW4	6,60
533014500	NOZZLE §225 CH12*14 OVEN GN 2/1	6,60
533055100	NOZZLE §215 CH12*14 L-CW4	6,60
533056300	NOZZLE §240 CH12*14	6,60
533069700	BY PASS COCK §075 25ST	11,00
533069400	BY PASS COCK §065 25ST	11,00
533097600	BY PASS COCK §090 25ST	11,00
531031600	HORIZON.THERMOSTATIC TAP BY-PASS 75	121,00
531033800	HORIZON.THERMOSTATIC TAP BYPASS §65	121,00
531052500	GAS COCK 25ST BY PASS D090 HORIZ.P	127,00



COMPONENTI COMUNI FORNO S70 GN2/1 GAS STATICO IMPIANTO V00 >=19_8501####
<=20_9999####
Tav. 560012300M02P00

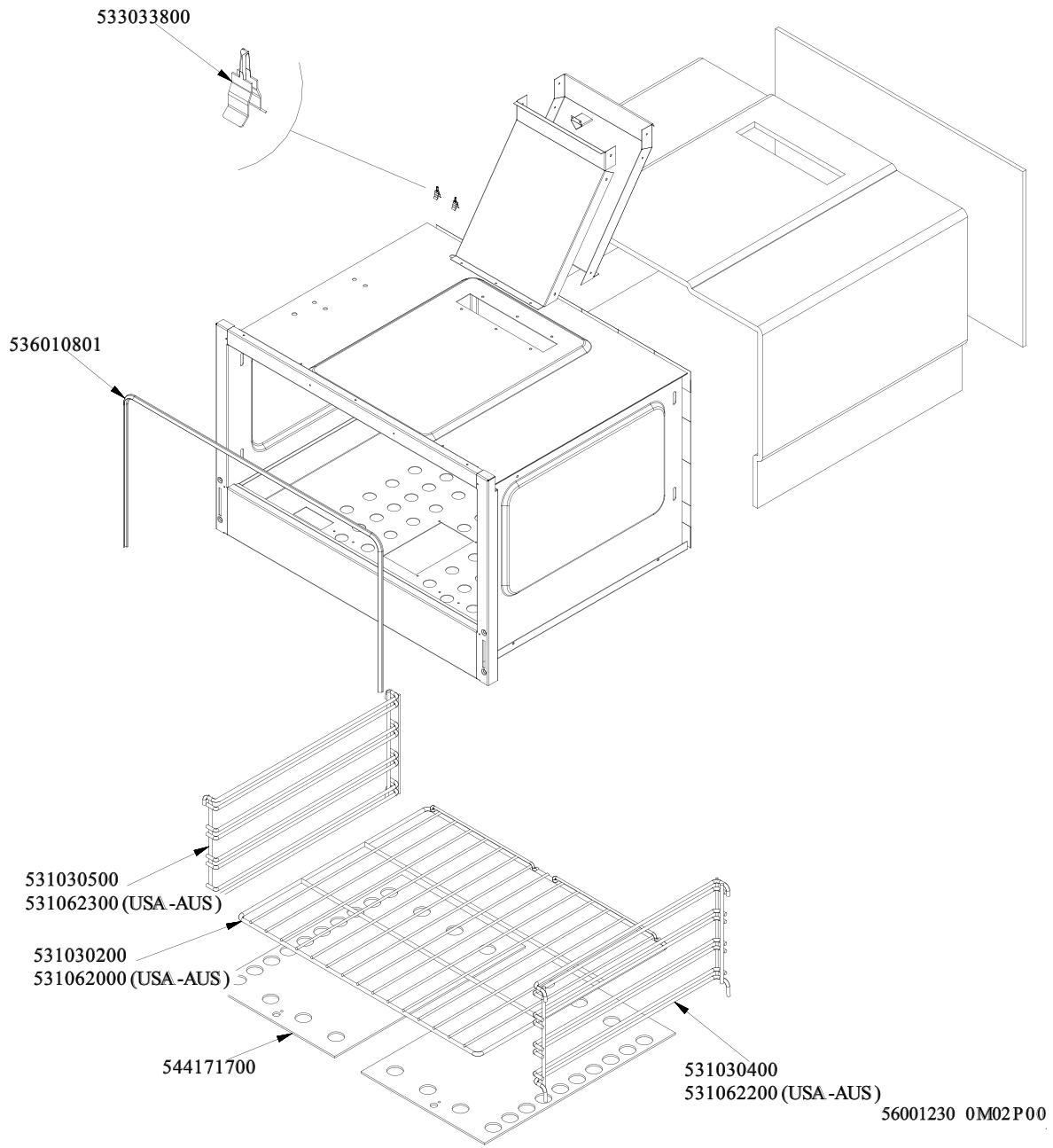



COMPONENTI COMUNI FORNO S70 GN2/1 GAS STATICO IMPIANTO V00 >=19_8501####
<=20_9999#### - COMPONENTI COMUNI FORNO S70 GN2/1 GAS STATICO IMPIANTO V00

Code	Description	Price €
533033800	LOCK SPRING FOR BULB §6	4,55
536010801	OVEN GASKET GN 2/1 (1308)	13,20
531030500	LHD SUPPORT GRID FOR OVEN OF 70LINE	31,70
531062300	LHD SUPPORT GRID FOR OVEN OF 70LINE	0,00
531030200	OVEN GRID GN 2/1 FOR 70 LINE	39,45
531062000	OVEN GRID GN 2/1 FOR 70 LINE	0,00
544171700	BOTTOM FOR GAS OVEN GN2/1 700LINE	80,00
531030400	RHD SUPPORT GRID FOR OVEN OF 70LINE	31,70
531062200	RHD SUPPORT GRID FOR OVEN OF 70LINE	0,00
-	-	



COMPONENTI COMUNI FORNO S70 GN3/1 PORTA INOX >=19_8501#### <=20_9999####
Tav. 560099900M00P00

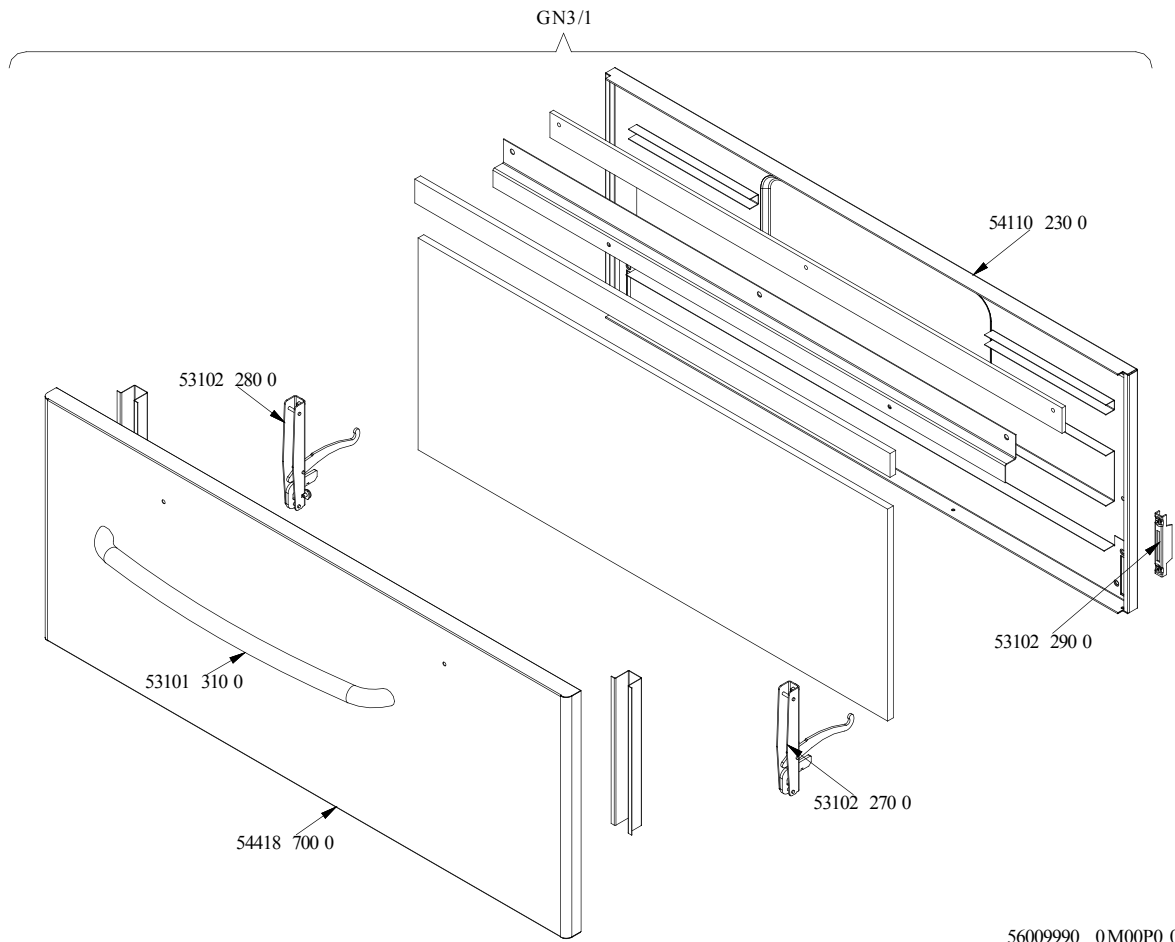



COMPONENTI COMUNI FORNO S70 GN3/1 PORTA INOX >=19_8501#### <=20_9999#### -
COMPONENTI COMUNI FORNO S70 GN3/1 PORTA INOX

Code	Description	Price €
541102300	GAS OVEN INNER DOOR GN 3/1 S.70	169,00
531022800	531022800N DOOR HINGE S.70	28,55
531022900	HINGE ROLLER HOLDER FOR 700-OVEN	9,90
531013100	OVEN DOOR HANDLE OF 70/90-LINE	115,00
531022700	LEFT OVEN DOOR HINGE 70LINE	28,55
544187000	OVEN DOOR GN 3/1 S.70	138,00



COMPONENTI COMUNI COMANDO E BRUCIATORE PC-G S70 1UR V00 >=19_8501#### <=20_9999####
 Tav. 560038700M02P00

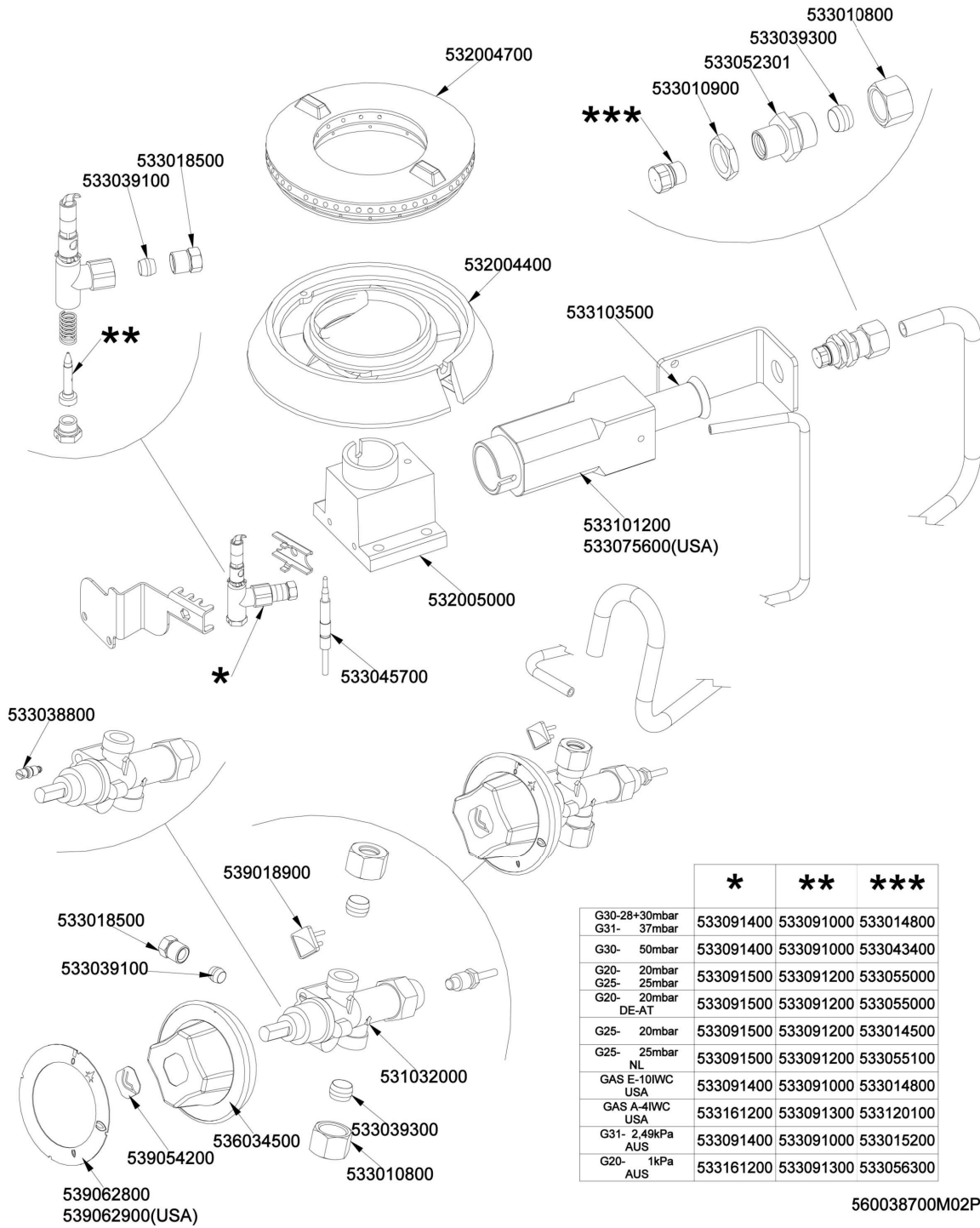

	*	**	***
G30-28+30mbar	533091400	533091000	533014800
G31- 37mbar	533091400	533091000	533043400
G30- 50mbar	533091400	533091000	533043400
G20- 20mbar	533091500	533091200	533055000
G25- 25mbar	533091500	533091200	533055000
G20- 20mbar DE-AT	533091500	533091200	533055000
G25- 20mbar	533091500	533091200	533014500
G25- 25mbar NL	533091500	533091200	533055100
GAS E-10IWC USA	533091400	533091000	533014800
GAS A-4IWC USA	533161200	533091300	533120100
G31- 2,49kPa AUS	533091400	533091000	533015200
G20- 1kPa AUS	533161200	533091300	533056300

560038700M02P00



COMPONENTI COMUNI COMANDO E BRUCIATORE PC-G S70 1UR V00 >=19_8501#### <=20_9999####
- COMPONENTI COMUNI COMANDO E BRUCIATORE PC-G S70 1UR V00

Code	Description	Price €
533010800	TUBE NUT D.10 M16*1,5	6,60
533039300	BICONE §10	5,55
533052301	JOINT FOR NOZZLE HOLDER	8,85
532004700	BURNER COVER RING UR D128	42,75
533010900	NUT M14*1 H.4	5,55
533018500	FITTING FOR BICONE D.6 M10*1	4,55
533039100	BICONE §6	5,55
532004400	BIG BURNER BODY 70LINE P.	40,60
533103500	AIR ADJUSTMENT BUSHING D22 EST.H57	9,90
533101200	BURNER VENTURI UR	27,40
533075600	BURNER VENTURI 7,5KW S70 USA	31,70
532005000	ELBOW FITTING OF BURNER VENTURI UR	37,30
533045700	THERMOCOUPLE M9*1 500	16,50
533038800	75 BY-PASS FOR 21S TAP	9,90
539018900	INDEX FOR KNOB W/RED SIGN	5,55
533018500	FITTING FOR BICONE D.6 M10*1	4,55
533039100	BICONE §6	5,55
531032000	GAS COCK P.V.BY-PASS Ø075	65,60
536034500	KNOB §77 4P. §08*6,5	5,55
533039300	BICONE §10	5,55
539054200	STAMP Ø20,5 CR."L" LOTUS R.	6,60
533010800	TUBE NUT D.10 M16*1,5	6,60
539062800	RED STICKING DISK 72	6,60
539062900	RED STICKING DISK 72 USA	6,60
533091400	P.NOZZLE S100 UG.§20 PC90 LPG-FLUS	17,50
533091500	PILOT NOZZLE S.100 §30 PC90 NAT.GAS	17,50
533161200		17,50
533091000	NOZZLE 0.100 §20	6,60
533091200	PILOT NOZZLE 0100 Ø35 PIL.PC	6,60
533091300	PILOT NOZZLE 0100 Ø40 PIL.PC	6,60
533014800	NOZZLE §135 CH12*14,0	6,60
533043400	NOZZLE §117 CH12*14 G-PC4 UR	6,60
533055000	NOZZLE §205 CH12*14 G25 CW4	6,60
533014500	NOZZLE §225 CH12*14 OVEN GN 2/1	6,60
533055100	NOZZLE §215 CH12*14 L-CW4	6,60
533014800	NOZZLE §135 CH12*14,0	6,60
533120100	NOZZLE §210 CH12*14,0	5,55
533015200	NOZZLE §145 CH12*14 F-FP/CP6	6,60
533056300	NOZZLE §240 CH12*14	6,60



COMPONENTI COMUNI COMANDO E BRUCIATORE PC-G S70 3SR V00 >=19_8501#### <=20_9999####
 Tav. 560038500M02P00

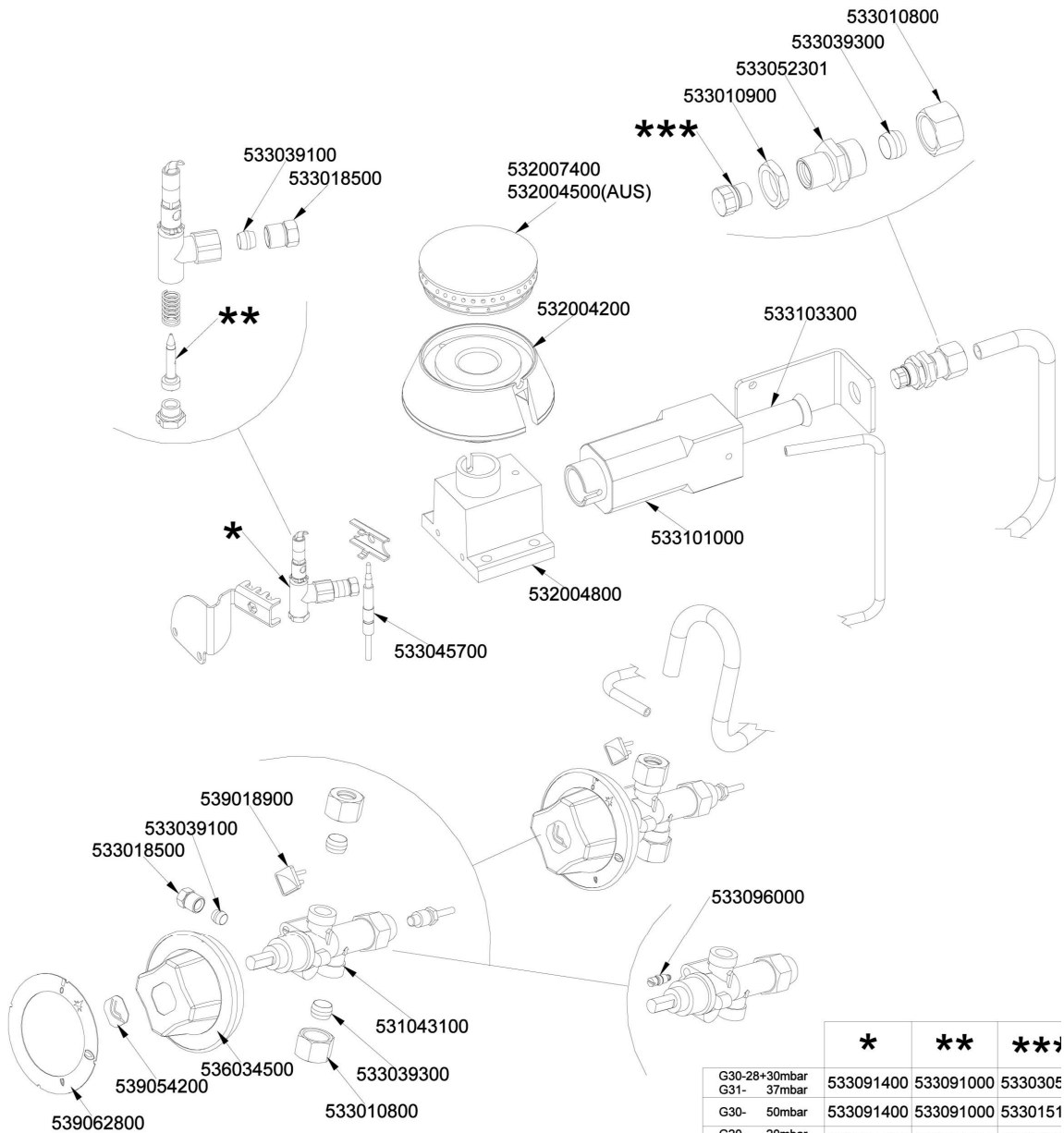

	*	**	***
G30-28+30mbar	533091400	533091000	5330305
G31- 37mbar			
G30- 50mbar	533091400	533091000	5330151
G20- 20mbar	533091500	533091200	5330152
G25- 25mbar			
G20- 20mbar DE-AT	533091500	533091200	5330152
G25- 20mbar	533091500	533091200	5330308
G25- 25mbar NL	533091500	533091200	5330149
G31- 2,49kPa AUS	533091400	533091000	5330193
G20- 1kPa AUS	533161200	533091300	5330303



COMPONENTI COMUNI COMANDO E BRUCIATORE PC-G S70 3SR V00 >=19_8501#### <=20_9999####
- COMPONENTI COMUNI COMANDO E BRUCIATORE PC-G S70 3SR V00

Code	Description	Price €
533010800	TUBE NUT D.10 M16*1,5	6,60
533039300	BICONE §10	5,55
533052301	JOINT FOR NOZZLE HOLDER	8,85
533010900	NUT M14*1 H.4	5,55
533039100	BICONE §6	5,55
532007400	BURNER COVER RING Ø073 4 Z	25,25
533018500	FITTING FOR BICONE D.6 M10*1	4,55
532004500	BURNER COVER RING SR D73	25,25
532004200	SMALL BURNER BODY 70LINE P.	35,00
533103300	AIR ADJUSTMENT BUSHING D16 EST.H57	9,90
533101000	BURNER VENTURI SR	27,40
532004800	ELBOW FITTING OF BURNER VENTURI SR	37,30
533045700	THERMOCOUPLE M9*1 500	16,50
539018900	INDEX FOR KNOB W/RED SIGN	5,55
533039100	BICONE §6	5,55
533018500	FITTING FOR BICONE D.6 M10*1	4,55
533096000	§50 BY-PASS COCK 20S-21S	11,00
531043100	B.PASS §50 SAFETY COCK PC/CF 70	64,60
539054200	STAMP Ø20,5 CR."L" LOTUS R.	6,60
533039300	BICONE §10	5,55
536034500	KNOB §77 4P. §08*6,5	5,55
539062800	RED STICKING DISK 72	6,60
533010800	TUBE NUT D.10 M16*1,5	6,60
533091400	P.NOZZLE S100 UG.§20 PC90 LPG-FLUS	17,50
533091500	PILOT NOZZLE S.100 §30 PC90 NAT.GAS	17,50
533091400	P.NOZZLE S100 UG.§20 PC90 LPG-FLUS	17,50
533161200		17,50
533091000	NOZZLE 0.100 §20	6,60
533091200	PILOT NOZZLE 0100 Ø35 PIL.PC	6,60
533091000	NOZZLE 0.100 §20	6,60
533091300	PILOT NOZZLE 0100 Ø40 PIL.PC	6,60
533030500	NOZZLE §90 CH12X14 G30/CE	6,60
533015100	NOZZLE §80 CH12*14 F-FP/CP6	6,60
533015200	NOZZLE §145 CH12*14 F-FP/CP6	6,60
533030800	NOZZLE §155 CH12X14 M-CW	6,60
533014900	NOZZLE §150 CH12*14 F-FQ5 L-FQ6	6,60
533019300	NOZZLE §100 G-FQ5 F-CW	6,60
533030300	NOZZLE §160 CH12*14 M-FPG	6,60



COMPONENTI COMUNI COMANDO E BRUCIATORE PC-G S70 2R V00 >=19_8501#### <=20_9999####
 Tav. 560038600M02P00

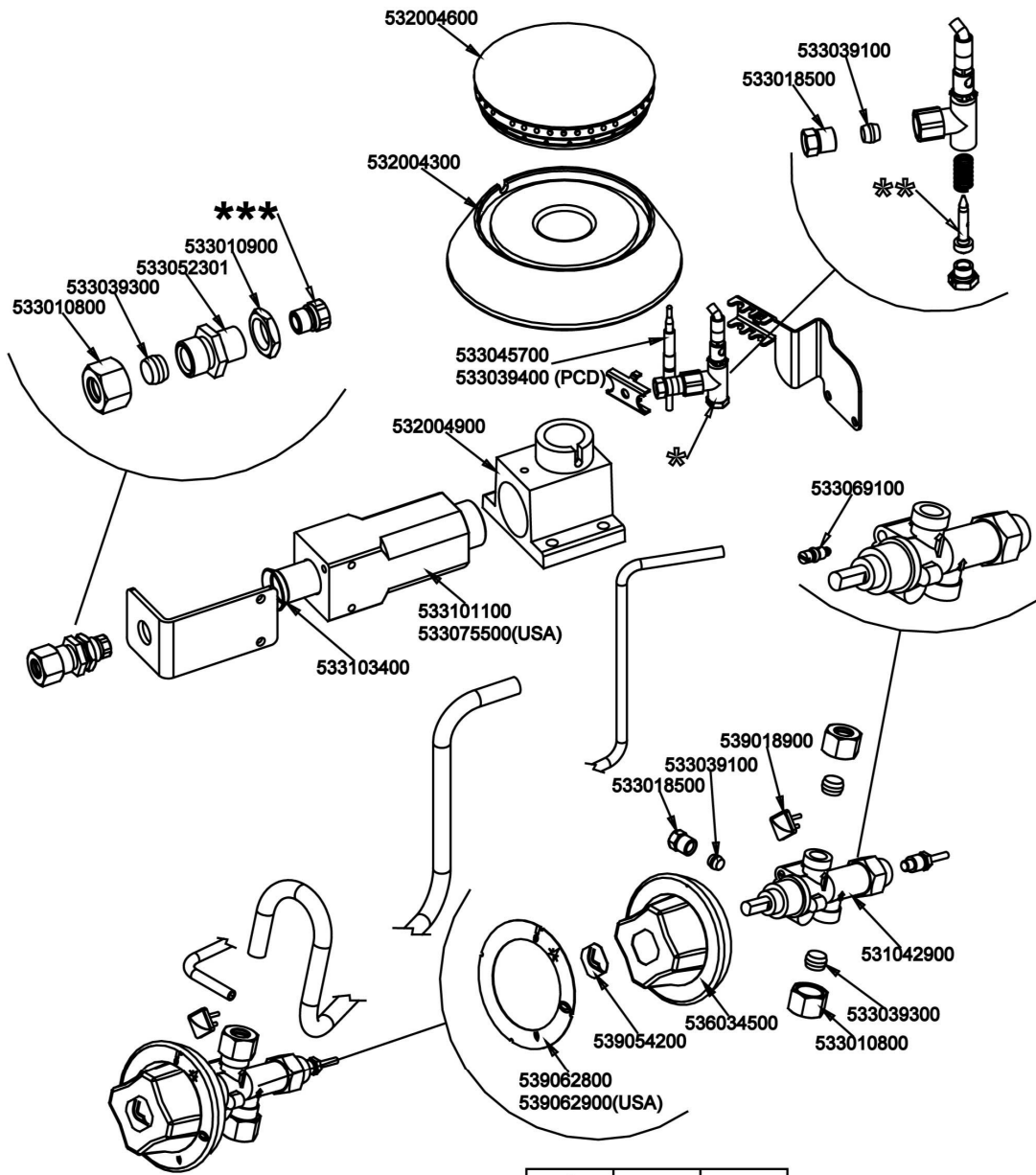

	*	**	***
G30-28+30mbar G31- 37mbar	533091400	533091000	533043900
G30- 50mbar	533091400	533091000	533019300
G20- 20mbar G25- 25mbar	533091500	533091200	533031000
G20- 20mbar DE-AT	533091500	533091200	533031000
G25- 20mbar	533091500	533091200	533043500
G25- 25mbar NL	533091500	533091200	533019400
GAS E-10IWC USA	533091400	533091000	533043200
GAS A-4IWC USA	533161200	533091300	533043100
G31- 2,49kPa AUS	533091400	533091000	533043900
G20- 1kPa AUS	533161200	533091300	533043500

560038600M02P00



COMPONENTI COMUNI COMANDO E BRUCIATORE PC-G S70 2R V00 >=19_8501#### <=20_9999#### -
COMPONENTI COMUNI COMANDO E BRUCIATORE PC-G S70 2R V00

Code	Description	Price €
532004600	BURNER COVER RING R D104	27,40
533039100	BICONE §6	5,55
533018500	FITTING FOR BICONE D.6 M10*1	4,55
532004300	MIDDLE BURNER BODY 70LINE P.	37,30
533010900	NUT M14*1 H.4	5,55
533052301	JOINT FOR NOZZLE HOLDER	8,85
533039300	BICONE §10	5,55
533010800	TUBE NUT D.10 M16*1,5	6,60
533045700	THERMOCOUPLE M9*1 500	16,50
533039400	THERMOCOUPLE M9*1*850	14,30
532004900	ELBOW FITTING OF BURNER VENTURI R	37,30
533069100	BY PASS COCK §60 20S	11,00
533101100	BURNER VENTURI R	27,40
533075500	BURNER VENTURI 5,5KW S70 USA	31,70
533103400	AIR ADJUSTMENT BUSHING D20 EST.H57	9,90
539018900	INDEX FOR KNOB W/RED SIGN	5,55
533039100	BICONE §6	5,55
533018500	FITTING FOR BICONE D.6 M10*1	4,55
531042900	B.PASS §60 SAFETY COCK PC/CF 90	64,60
533034500	PROCESSING CODE	
539054200	STAMP Ø20,5 CR."L" LOTUS R.	6,60
533039300	BICONE §10	5,55
533010800	TUBE NUT D.10 M16*1,5	6,60
539062800	RED STICKING DISK 72	6,60
539062900	RED STICKING DISK 72 USA	6,60
533091400	P.NOZZLE S100 UG.§20 PC90 LPG-FLUS	17,50
533091500	PILOT NOZZLE S.100 §30 PC90 NAT.GAS	17,50
533161200		17,50
533091000	NOZZLE 0.100 §20	6,60
533091200	PILOT NOZZLE 0100 Ø35 PIL.PC	6,60
533091300	PILOT NOZZLE 0100 Ø40 PIL.PC	6,60
533043900	NOZZLE §115 CH12*14 F-CW4	6,60
533019300	NOZZLE §100 G-FQ5 F-CW	6,60
533031000	NOZZLE §175 CH12X14	6,60
533043500	NOZZLE §190 CH12*14 G25 PC4R	6,60
533019400	NOZZLE §180 CH12*14 L-FQ5	6,60
533043200	NOZZLE §110 G30 (LPG) CH12X14	6,60
533043100	NOZZLE §185 G25 CH12X14	6,60
533043900	NOZZLE §115 CH12*14 F-CW4	6,60
533043500	NOZZLE §190 CH12*14 G25 PC4R	6,60